

# *MS-4002 Master Station User Manual*



**PROPRIETARY NOTICE**

The product information and design disclosed herein were originated by and are the property of Telex Communications, Inc. Telex reserves all patent, proprietary design, manufacturing, reproduction, use and sales rights thereto, and to any article disclosed therein, except to the extent rights are expressly granted to others.

**COPYRIGHT NOTICE**

Copyright 2006 by Telex Communications, Inc. All rights reserved. Reproduction, in whole or in part, without prior written permission from Telex is prohibited.

**WARRANTY NOTICE**

See the enclosed warranty card for further details.

**CUSTOMER SUPPORT**

Technical questions should be directed to:

Customer Service Department  
RTS/Telex Communications, Inc.  
12000 Portland Avenue South  
Burnsville, MN 55337 USA  
Telephone: 800-392-3497  
Fax: 800-323-0498  
Factory Service: 800-553-5992

**RETURN SHIPPING INSTRUCTIONS**

Customer Service Department  
Telex Communications, Inc. (Lincoln, NE)  
Telephone: 402-467-5321  
Fax: 402-467-3279  
Factory Service: 800-553-5992

Please include a note in the box which supplies the company name, address, phone number, a person to contact regarding the repair, the type and quantity of equipment, a description of the problem and the serial number(s).

**SHIPPING TO THE MANUFACTURER**

All shipments of product should be made via UPS Ground, prepaid (you may request from Factory Service a different shipment method). Any shipment upgrades will be paid by the customer. The equipment should be shipped in the original packing carton. If the original carton is not available, use any suitable container that is rigid and of adequate size. If a substitute container is used, the equipment should be wrapped in paper and surrounded with at least four (4) inches of excelsior or similar shock-absorbing material. All shipments must be sent to the following address and must include the Proof of Purchase for warranty repair. Upon completion of any repair the equipment will be returned via United Parcel Service or specified shipper, collect.

Factory Service Department  
Telex Communications, Inc.  
8601 Cornhusker Hwy.  
Lincoln, NE 68507 U.S.A.  
Attn: Service

This package should include the following:

Part Number	Description	Qty
9010-7799-000	MS-4002 Final Assembly	1
2504000300	Power Cord	1
9160-7353-002	1 1/4" Face Plate, Left, Black	1
9160-7353-003	1 1/4" Face Plate, Right, Black	1
9350-7799-000	MS-4002 User Manual	1
38109-675	Statement of Conformity	1
38110-390	Warranty Card	1
38109-668	User Information Power Cord Requirement	1
9110-7353-000	Rackmount Bracket	2

# Table of Contents

<i>Introduction</i> .....	1	<i>Calling an Intercom Channel</i> .....	12
<i>Description</i> .....	1	<i>Microphone Mute During Talk</i> .....	12
<i>Features</i> .....	1	<i>All Talk</i> .....	12
<i>Reference View</i> .....	2	<i>Public Address (PA)</i> .....	12
<i>Default Jumper Settings</i> .....	4	<i>Turning the Program Input ON and OFF</i> .....	12
<i>Installation</i> .....	5	<i>Using Mic Kill</i> .....	13
<i>Direct Program Listen Enable/Disable</i> .....	5	<i>Incoming Call Beep ON/OFF</i> .....	13
<i>Mounting</i> .....	5	<i>Test Tone</i> .....	13
<i>Connections</i> .....	5	<i>Standard Programming</i> .....	13
<i>External Program Input and PA Output</i> <i>Balanced (BAL) or Unbalanced (UNBAL)</i> <i>Operation</i> .....	6	<i>Advanced Programming Using the MS-4002</i> .....	15
<i>Cables</i> .....	7	<i>Call Signal Send and Receive, Channel 1</i> .....	15
<i>Power-up Check</i> .....	8	<i>Call Signal Send and Receive, Channel 2</i> .....	16
<i>Sidetone Adjustment</i> .....	9	<i>Call Signal Send and Receive, Channel 3</i> .....	16
<i>Voice-Activated Microphone (Vox) Setup</i> .....	10	<i>Call Signal Send and Receive, Channel 4</i> .....	16
<i>Operation</i> .....	11	<i>Program Interrupt 1</i> .....	16
<i>Operation</i> .....	11	<i>Program Interrupt 2</i> .....	17
<i>Normal vs. Programming vs. Advanced</i> <i>Programming Mode</i> .....	11	<i>Program Interrupt 3</i> .....	17
<i>Volume Adjustment</i> .....	11	<i>Program Interrupt 4</i> .....	17
<i>Receiving Calls</i> .....	11	<i>Incoming Call Beep, Headset</i> .....	17
		<i>Incoming Call Beep, Panel Speaker</i> .....	18
		<i>Listen 2 to Speaker 1</i> .....	18
		<i>Listen 3 to Speaker 1</i> .....	18
		<i>Listen 4 to Speaker 1</i> .....	18
		<i>Specifications</i> .....	19



---

## *Description*

The MS-4002 is a complete 4-channel master station and system power supply (24 VDC, up to 3.5 Amps total power) in a single unit. Simply plug it into any AC power outlet from 100 to 240 volts, add a microphone or headset, connect intercom stations to the backpanel, and it's ready to communicate. It has 1-, 2-, 3- and 4-channel connectors, so a separate breakout is not needed to mix multiple intercom stations. The MS-4002 fits in a standard 19-inch equipment rack and is 1 rack unit high. The basic MS-4002 can communicate with four intercom channels. This number can be increased by connecting an optional EMS-4001 Expansion Station. Each EMS-4001 adds four channels, and up to four of these expansion stations can be connected for a total of 20 channels.

---

## *Features*

- **Auto-Sensing Headset Connector**  
The MS-4002 has a built-in auto-sensing headset connector that dynamically determines whether the headset connected to the system is dynamic or electret.
- **Speaker Station or Headset Station**  
Use the built-in speaker for listening and add an optional Telex MCP-90 series gooseneck panel microphone for talk-back. Turn OFF the speaker volume and plug in any Telex headset for private communication.
- **Public Address (PA) Output, with PA Key**  
Use the intercom microphone to talk over a PA system.
- **Back-lit Keys**  
Back-lit keys improve visibility in low-light environments.
- **Incoming Call Indications**  
Red flashing call lights with an optional beep tone, if desired.
- **Mic Kill Key**  
Turn off all microphones for a specific channel to quickly clear traffic on the channel.
- **Program Input for each Channel**  
Connect any line-level audio source for monitoring speaker or headset, or for routing to an intercom channel. The program audio to the channel can be set to interrupt while the MS-4002 operator is talking on the channel.
- **Listening with Externally Powered Speakers**  
Connect externally powered speakers and monitor channels 1, 2, 3, and 4.
- **Expandable**  
Add more channels by connecting optional EMS-4001 Expansion Stations. Each EMS-4001 adds four additional powered channels (up to twenty channels).
- **Clear - Com™\* Compatible**  
Can run in unbalanced mode.

*\* Brand names mentioned are the property of their respective companies.*

## Reference View

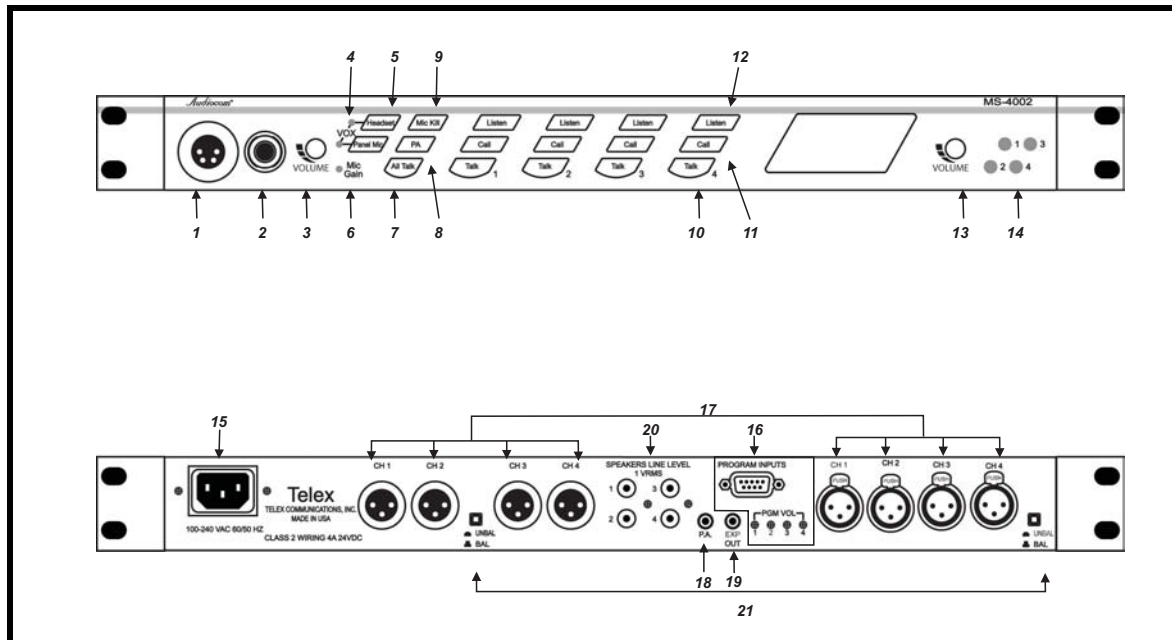

Figure 1. MS-4002 Reference View

1. *Auto-sensing Mic Headset Connector*  
Accepts headsets with monaural headphones; either dynamic and electret microphone.
2. *Panel Mic Connector*  
Accepts an electret gooseneck microphone. The model MCP-90 series panel mic connector is a 1/4" stereo plug, with a threaded shaft for easy installation.
3. *Volume Control*  
Adjusts headphone volume only.
4. *Vox Trimmers*  
Used with the voice-activated microphone feature. Separate trimmers to adjust the voice activation level for the headset and panel microphones.
5. *Headset and Panel Mic Keys*  
Used to manually activate either the headset or panel microphone, whichever is being used.
6. *Mic Gain*  
Used to adjust the level at which audio is sent from the microphone.
7. *All Talk Key*  
Used to talk to any station on any channel. This includes all the MS-4002 channels and any channels connected through an EMS-4001 Expansion Station.
8. *PA Key*  
If the MS-4002 is connected to a public address (PA) system, this key may be used to talk over the public address system.
9. *Mic Kill Key*  
Used to turn off the microphones of any intercom station on a channel. Also, used to activate program inputs and the audible beep feature for incoming calls.
10. *Intercom Talk Keys*  
Momentary or latching (hands-free) operation possible.
11. *Call Keys*  
Used to place calls on intercom channels and to indicate incoming calls.
12. *Intercom Listen Keys*  
Momentary or latching (hands-free) operation possible.

- 
- 13. *Speaker Volume Control***  
Volume control adjusts the level to the front panel speaker. If an external speaker is used, volume must be adjusted at the speaker.
  - 14. *Channel Status Indicators***  
The indicators are GREEN for normal operation and RED when there is an overload or short circuit. Once the fault is resolved, the system will Auto-reset.
  - 15. *Universal AC Power Input***  
The MS-4002 accepts any input power in the range of 100-240 VAC, 50/60 Hz.
  - 16. *Program Inputs Connector and Trimmers***  
Each intercom channel has its own program input and level adjust trimmer. The program inputs may be turned ON or OFF via the front panel and they may be set to interrupt during talk, if desired.
  - 17. *Intercom Line Connector***  
Two connectors are provided for each channel for loop-through connection of 1-channel intercom stations.
  - 18. *PA Output***  
Connects to a public address system.
  - 19. *Expansion Out Connector***  
Connects to an EMS-4001 Expansion Station.
  - 20. *Speaker Output Jacks***  
May be used with externally-powered loudspeakers for monaural or binaural listening configurations.
  - 21. *Balanced/Unbalanced Selector Switches***  
The selector switches set the MS-4002 for compatibility with either Audiocom or Clear-Com™ channel connector pin-outs, channel power requirements, and call signaling requirements. *Both switches must be in the same position.*

Default Jumper Settings

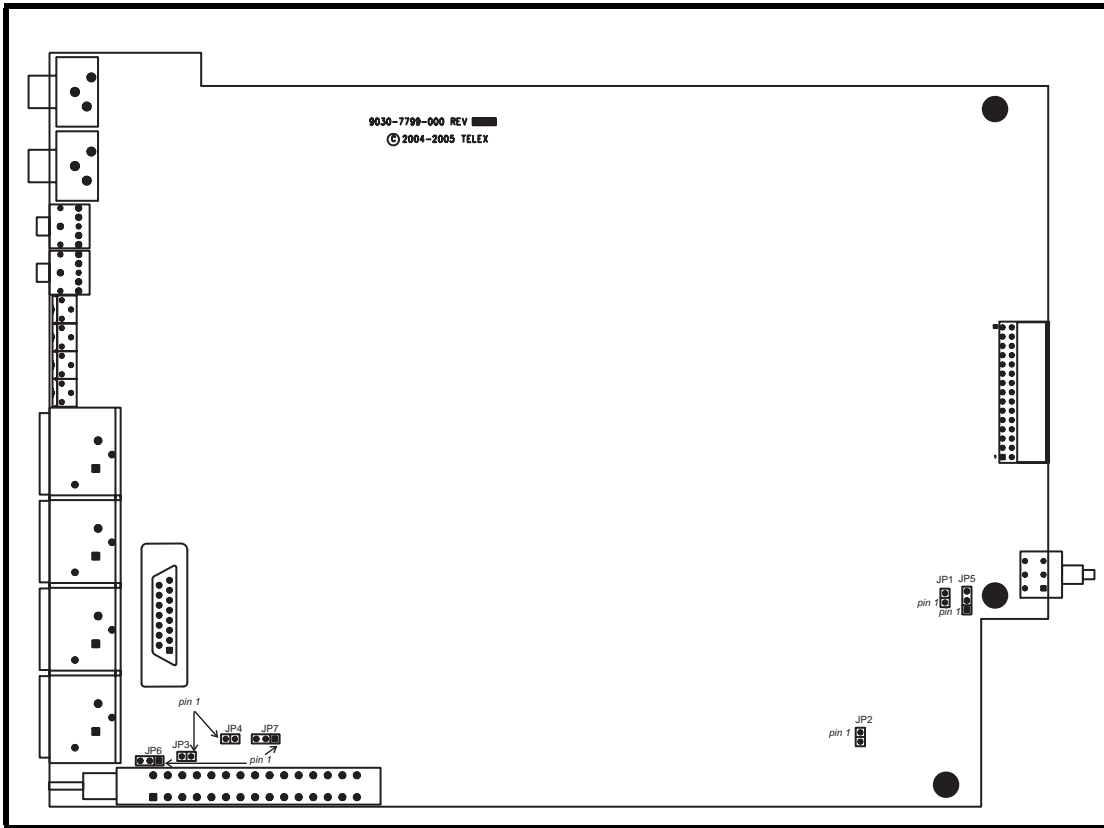

Figure 2. Default Jumper Settings

NOTE: These jumpers settings apply only to board 9030-7799-000 Rev G or higher.

	Description	Default Position
<b>JP1</b>	Panel Microphone Power Connection	Shorted on Pins 1&2
<b>JP2</b>	Headset Microphone Power Connection	Shorted on Pins 1&2
<b>JP3</b>	Channel 2 Line Connection Format Select	Shorted on Pins 1&2
<b>JP4</b>	Channel 4 Line Connection Format Select	Shorted on Pins 1&2
<b>JP5</b>	Panel Microphone Audio Connection	Shorted on Pins 2&3
<b>JP6</b>	Channel 1 Line Connection Format Select	Shorted on Pins 1&2
<b>JP7</b>	Channel 3 Line Connection Format Select	Shorted on Pins 1&2

---

### *Direct Program Listen Enable/Disable*

By default, each MS-4002 program input can be heard locally by all intercom stations. Program input routing to the intercom channels can be turned ON or OFF via the MS-4002 front panel programming. For more information on programming, see “Standard Programming” on page 13 and “Advanced Programming Using the MS-4002” on page 15.

---

### *Mounting*

The MS-4002 mounts in a standard 19-inch equipment rack and is 1 rack unit (RU) high. When mounting the MS-4002, install the supplied black face plates on the appropriate sides. The face plates should be mounted with the grooves on the top, see Figure 1, “MS-4002 Reference View,” on page 2.

**NOTE:** You may have to perform the sidetone adjustment, See “Sidetone Adjustment” on page 9, after all components are connected. With the MS-4002 being rack mounted, you may not be able to access the sidetone trimmers. In this case, you can position the MS-4002 in the rack and make all required connections. Then, adjust the sidetone trimmers before installing and tightening all rack mount screws.

---

### *Connections*

Refer to the following paragraphs and sample connection drawings on page 6, 7 and 8.

## External Program Input and PA Output

Connections for external program input and PA output are shown in Figure 3, EMS-4001 Expansion Station Connection (optional component). Refer to the EMS-4001 User Instruction Manual for detailed connection information.

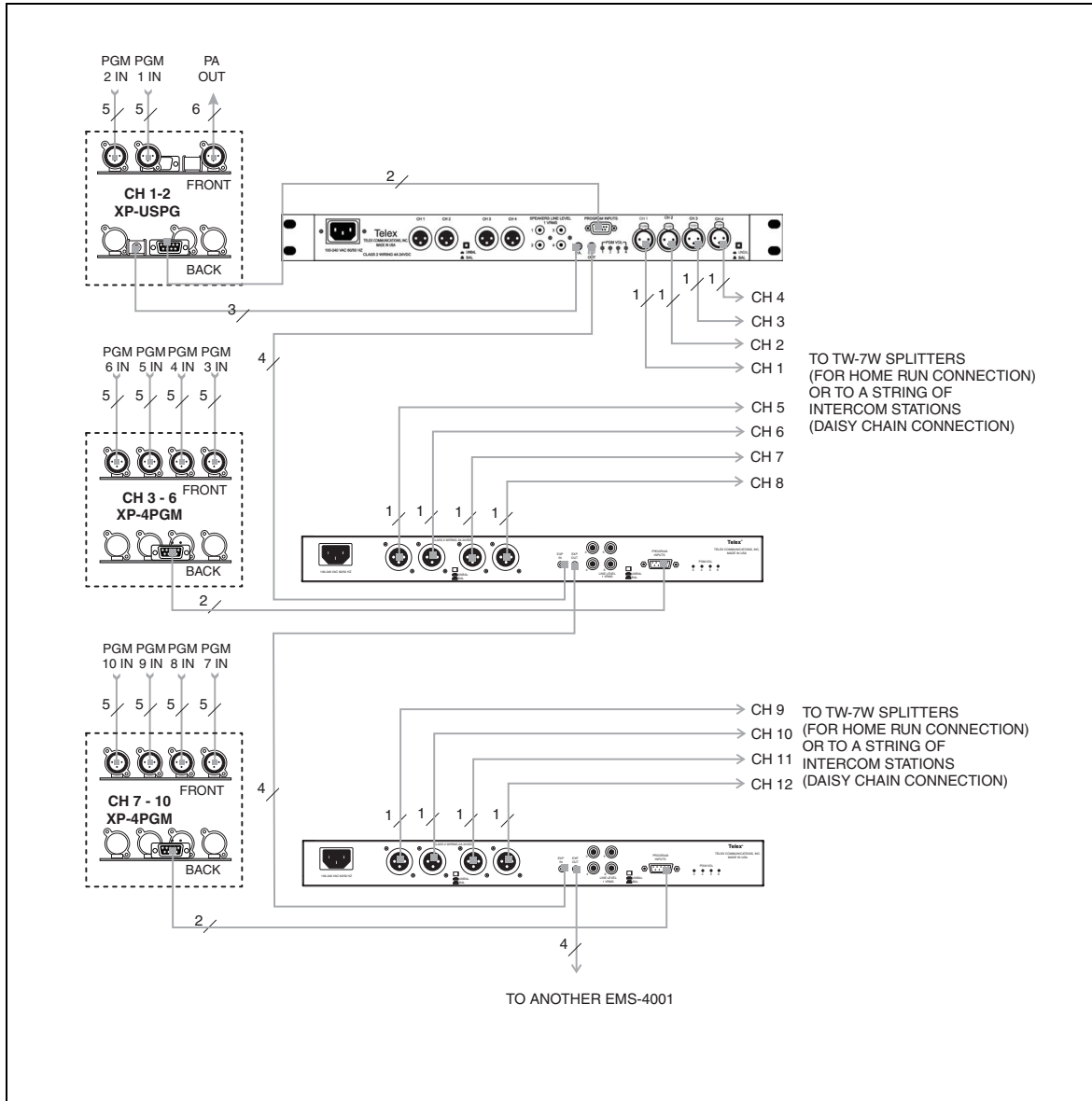

Figure 3. Example of MS-4002 and EMS-4001 system.

## Balanced (BAL) or Unbalanced (UNBAL) Operation

Balanced or Unbalanced operation determines if the MS-4002 is compatible with Clear-Com™ equipment. If the unit is configured to Balanced operation it can only use Telex equipment. If the unit is set to Unbalanced operation, it will work with Clear-Com™ or Clear-Com compatible equipment only.

**NOTE:** There are two switches on the MS-4002 unit that control the Balanced/Unbalanced operation. You must set both of these switches in the same position for proper operation, see Figure 4.

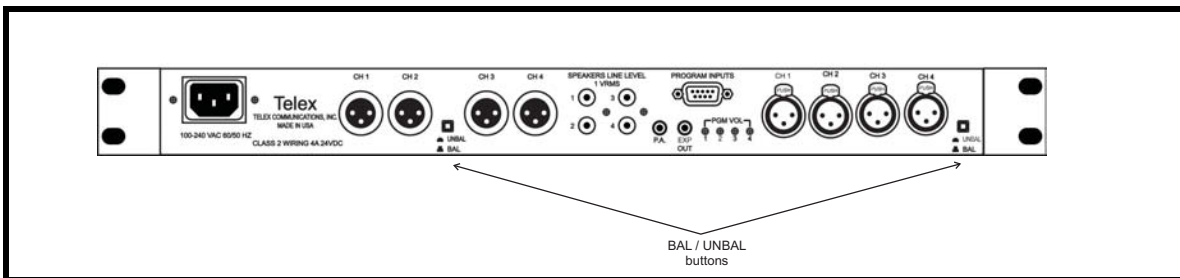

Figure 4. MS-4002 Back Panel Balanced and Unbalanced Operation Switches

**Default: Balanced (BAL) Operation (Out)**

**Switch position: OUT (not depressed)    Balanced (Audiocom)**

**Switch position: IN (depressed)        Unbalanced (Clear-Com)**

## Cables

The numbers below correspond to the cable numbers in the connection drawings Figure 5, “Audiocom Intercom Cables,” on page 8.

1. 1-channel intercom cable. Sold separately. Use Telex “ME” cables, below.  
ME-25: 25’ (7.6 m) cable with Male and Female 3-pin XLR connectors.  
ME-50: 50’ (15.2 m) cable with Male and Female 3-pin XLR connectors.  
ME-100:100’ (30.4 m) cable with Male and Female 3-pin XLR connectors.

**NOTE:** When connecting from the MS-4002 to a TW-7W, keep cables as short as possible. Also, heavier gauge wire is recommended.

2. 2-channel intercom cable. Sold separately. Use Telex “ME/w” cables, below.  
ME-25/2: 25’ (7.6 m) cable with Male and Female 6-pin XLR connectors.  
ME-50/2: 50’ (15.2 m) cable with Male and Female 6-pin XLR connectors.  
ME-100/2: 100’ (30.4 m) cable with Male and Female 6-pin XLR connectors.
3. Y adapter cable. Sold separately. Use Telex CA-23-16.  
3 ft. (0.91 m) speaker cable with RCA plugs. One supplied with each SPS2001, and SPK-2000.
4. 18” (457 mm) EXP IN/OUT cable, stereo mini-plug to stereo mini-plug. One supplied with each EMS-4001.
5. Shielded patch cable, 9-pin Male D-sub to 9-pin Female D-sub. Customer local purchase. Available at most electronic shops. Note, all pins must be connected straight through: do not use an RS232 computer cable.
6. Shielded patch cable, stereo miniplug to stereo miniplug. Customer local purchase. Available at most electronic stores.
7. Shielded audio cable. Must have male 3-pin XLR connector at one end for connection to the XP-USPG or SP-4PGM program inputs. Pin-out for program inputs as follows:

Pin 1:    common  
Pin 2:    + program input  
Pin 3:    - program input

8. Shielded audio cable. Must have male 3-pin XLR connector at one end for connection to the XP-USPG PA output. Pin-out for PA output as follows:
  - Pin 1: common
  - Pin 2: + PA output
  - Pin 3: - PA output
  
9. 18” (457 mm) CHANNEL OUTPUT cable, 15-pin Male D-sub to 15-pin Female D-sub. One supplied with each XP-ES4000. (Optional component: see EMS-4001 User Manual for more detailed connection information.)

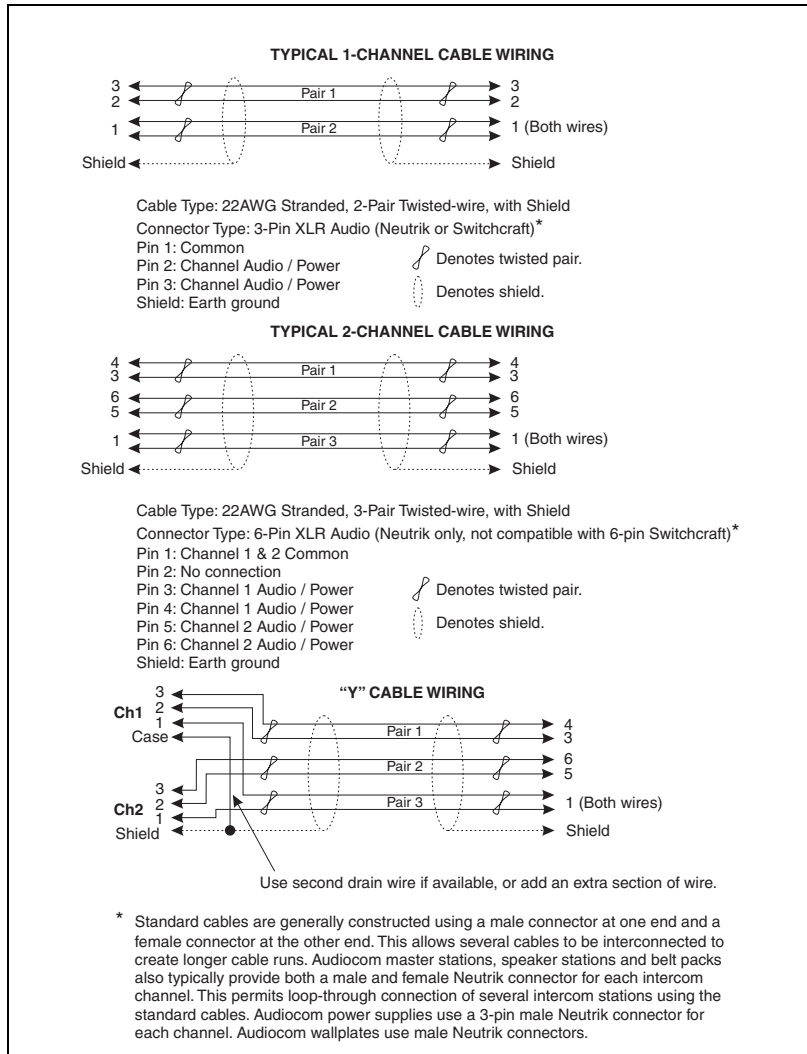

Figure 5. Audiocom Intercom Cables

### Power-up Check

Plug in the MS-4002. When power is first applied to the unit, it will perform a power-up reset (front panel indicators cycle through all possible colors and then turn off). This verifies the general operation of the intercom station and indicators.

## Sidetone Adjustment

The MS-4002 uses full-duplex audio (the same as a conventional telephone line) in which the talk and listen audio are sent and received on the same line. Thus, when you talk on a channel, you will also hear your own voice back in the speaker or headphones. This is called **sidetone**. If you are using the MS-4002 with a microphone and speaker, sidetone could cause unwanted feedback, since the microphone may pick up your returned voice audio and re-amplify it. This could also happen if you are using a headset where the ear cushions do not completely cover the ears. In either of these cases, you should minimize the amount of sidetone. Note, if you are using headphones that completely enclose the ears, a certain amount of your own voice level is desirable to overcome the muffled sensation when talking.

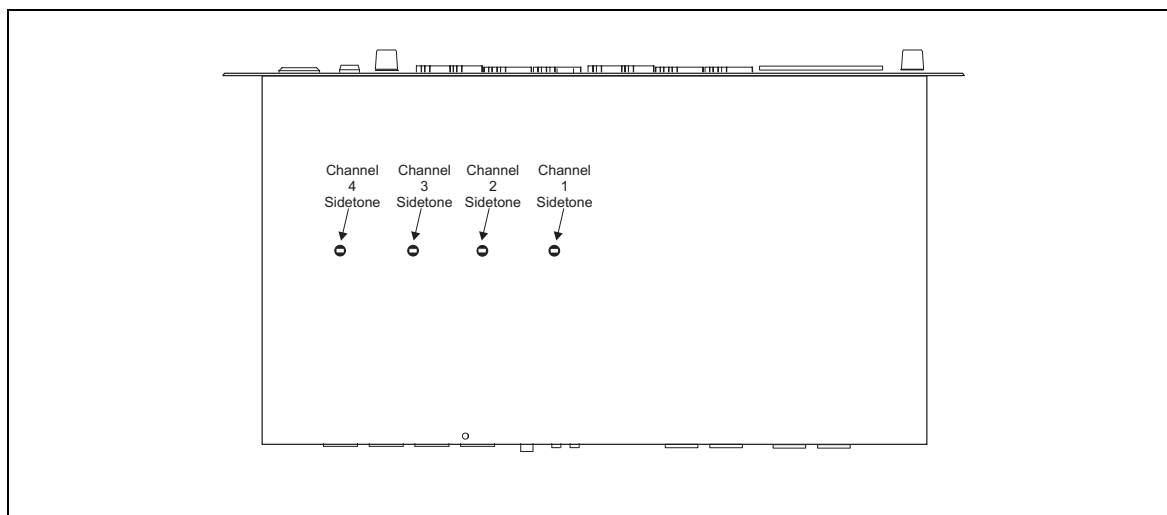

Figure 6. Sidetone Adjustment diagram (MS-4002 bottom view)

To Adjust the Sidetone, do the following:

**If you are using a speaker and microphone, or open-ear style headphones, adjust sidetone as follows:**

1. Simultaneously press the **All Talk** and **PA** keys to activate the test tone.
2. Tap the **channel 1 Call** key to send the test tone on channel 1.
3. Increase the **volume** until you can hear the test tone (See “MS-4002 Reference View” on page 2 for the volume control descriptions).
4. Using a small, standard screw-driver, adjust the **channel 1 sidetone** (Figure 6) through the access hole in the bottom of the MS-4002 to minimize the tone volume.
5. Tap the **channel 1 Call** key to turn off the test tone on channel 1 when finished.
6. Tap the **channel 2 Call** key, repeat the adjust for the channel 2 sidetone.
7. Tap **any other key**, except a Call key, to turn off the test tone when finished.

*\*To set channels 3 and 4, repeat steps 1 through 7.*

**If you are using headphones that completely enclose the ears, adjust sidetones as follows:**

1. Tap the **Headset** key to turn the headset microphone on.
2. Tap the **channel 1 Talk** key to turn it on.
3. While speaking into the microphone, use a small flat-bladed screwdriver to adjust the channel 1 Talk key to turn it so that you hear your voice at an acceptable level in the headphones.
4. Tap the **channel 1 Talk** key to turn it off when finished.
5. Tap the **channel 2 Talk** key to turn it on, and adjust the channel 2 sidetone as for channel 1.
6. Tap the **channel 2 Talk** key to turn it off when finished.

*\*To set channels 3 and 4, repeat steps 1 through 6.*

## *Voice-Activated Microphone (Vox) Setup*

If you are going to use Vox, you must adjust its level for proper operation. If the Vox level is too low, room noise will activate the microphone. If the Vox level is too high, the microphone will not activate when you begin talking.

To check and set the Vox level, do the following:

1. If you are using a headset, tap the **Headset** key **twice** to turn on headset Vox.  
OR  
If you are using a panel microphone, tap the **Panel Mic** key **twice** to turn on panel mic Vox.  
*Whichever key you tap, it will glow orange when the microphone is off and will flicker or turn green when sound is picked up by the microphone.*
2. Position the microphone at its **normal operation location**.  
*If you are using a headset, put the headset on and position the microphone about three fingers from your mouth.*
3. Insure that background noise is at the **normal operating level**.  
*Do not speak into the microphone.*
4. If the Headset or Panel Mic key is constantly glowing orange, turn the **Vox trimmer** clockwise until the key begins to flicker green (mic activating), then turn the trimmer slightly back in the counterclockwise direction until the Panel Mic key just returns to steady orange (mic off).  
*If you are wearing a headset, make sure that breathing and movement do not cause the Panel Mic key to flicker green. If they do, adjust the Vox control slightly more in the counterclockwise direction to eliminate this.*
5. **Speak** into the microphone in a normal voice, and verify the headset key immediately turns green when you talk.  
*If the key does not turn green, move the microphone closer to your mouth. If you are still unable to get satisfactory results, it may be that the microphone does not have the directional characteristics required for the noise level in the room. A directional, or cardioid, microphone is recommended when using Vox.*
6. To return the MS-4002 to normal operation, tap the **Mic Kill** key.

---

## *Operation*

**Note:** A quick-reference to the following operating features are in Table 7 on page 14.

### **Normal vs. Programming vs. Advanced Programming Mode**

The MS-4002 has three operating modes: *normal operating mode*, *standard programming mode* (see page 13), and *advance programming mode* (see page 15). In normal operating mode, the Mic Kill key will be unlit, and in programming mode it will be lit continuously. To return the MS-4002 to normal operation, if it has been left in programming mode, tap the Mic Kill key. For information on accessing Advanced Programming Mode, see “Advanced Programming Using the MS-4002” on page 15

### **Volume Adjustment**

If you are using a headset, adjust the intercom listen level with the left volume control on the front panel of the MS-4002. If you are using a speaker, adjust the intercom listen level with the right volume control next to the speaker. External speakers will require their own volume controls.

### **Receiving Calls**

1. When there is an incoming call signal on a channel, the Call key for that channel will flash red. There will also be a beep tone if the beep feature has been activated (see “Incoming Call Beep ON/OFF” on page 13).
2. Activate the microphone: If you are using a dynamic-mic headset or an electret-mic headset, tap the Headset key to turn the mic ON; if you are using a panel-mounted microphone, tap the Panel Mic key to turn the mic ON.

**NOTE:** You can also use the voice-activated microphone (Vox) feature. See “Voice-Activated Microphone (Vox) Setup” on page 10.

3. Tap ON the Talk and Listen keys for the calling channel and begin your conversation. Tap the keys OFF when finished.

**NOTE:** When you tap the Headset key, or the Panel Mic key, or any Talk or Listen key, it will lock in the ON position. Then tap the key again to turn it OFF. For momentary activation, press and hold the key. It will remain on as long as you hold it and then turn off when you release it.

### Calling an Intercom Channel

1. Press and hold the **Call** key for the channel that you want to call. An inaudible call signal will be sent, and your listen key for that channel will automatically turn ON in preparation to receive a verbal response.
2. When you hear a response, release the **Call** key.
3. If you are using manual microphone activation instead of Vox, make sure your microphone is ON: for a headset mic, tap the **Headset** key to turn it ON; for a panel-mounted microphone, tap the **Panel Mic** key to turn the mic ON.
4. Tap ON the **Talk** key for the channel you called to begin your conversation.
5. Tap OFF your **Talk** and **Listen** keys to end the conversation.

### Microphone Mute During Talk

You can mute the microphone while talking. Simply tap either the Headset key or the Panel Mic key, whichever is currently being used. Tap the key again to turn the microphone back on. (If you are using Vox, tap the key twice to reactivate Vox.)

### All Talk

You can talk to all intercom stations that currently have their listen keys activated. This applies to all channels of the MS-4002, as well as all the talk channels of any EMS-4001 Expansion Stations.

Use All Talk as follows:

1. If you are using manual microphone activation instead of Vox, make sure the proper microphone switch is turned ON (either Headset or Panel Mic).
2. Press and hold the **All Talk** key while talking. Release it when finished.

**NOTE:** To insure that the All Talk key is never accidentally left in the ON position, it does not latch.

---

### *Public Address (PA)*

If the PA output on the back panel of the MS-4002 is connected to a public address system, you can talk on the public address system as follows:

1. If you are using the manual microphone activation instead of Vox, make sure the proper microphone switch is turned ON (either Headset or Panel Mic).
2. Press and hold the **PA** key while talking. Release it when finished.

**NOTE:** To insure that the PA key is never accidentally left in the ON position, it does not latch.

---

### *Turning the Program Input ON and OFF*

1. Insure that program inputs have been connected at the back panel and the program sources are ON.
2. Press and hold the **Mic Kill** key for about 2 seconds, then release it.  
*It should now be glowing green to indicate the MS-4002 is in programming mode.*
3. The current status of the program inputs is indicated by the Talk keys. If the Channel 1 Talk key is lit, the program 1 input is currently activated to channel 1; if Channel 2 talk is lit, program 2 is activated to channel 2. Tap either **Talk** key to turn the program input for that channel ON or OFF.

**NOTE:** You can also turn the Program Input ON and OFF on channels three and four.

4. When the program inputs are configured as desired, tap the **Mic Kill** key to exit programming mode and return to normal operation.

5. Adjust Program **1, 2, 3, and 4** via the trimmers on the rear panel of the MS-4002. See “MS-4002 Reference View” on page 2.

---

## *Using Mic Kill*

If the Mic Kill feature has been enabled, you can use it to deactivate all talk keys on a single channel or on all channels. This feature is useful when a remote talk key has been left ON and is causing unwanted noise on a channel.

To use Mic Kill, do the following:

1. Tap the **Mic Kill** key.  
*It will blink green.*
2. Tap the **Talk** or **Listen** key for a channel to turn off all talk keys on that channel. Or, tap the **All Talk** key to turn off all talk keys.  
*The key you tap will turn green and the Mic Kill signal will be sent.*
3. Tap the **Mic Kill** to exit.

---

## *Incoming Call Beep ON/OFF*

Normally, incoming calls are indicated by red-flashing Call keys.

An optional beep tone can also be enabled as follows:

1. Press and hold the **Mic Kill** key for about 2 seconds, then release it. It should now be glowing green to indicate that the intercom station is in programming mode.
2. Tap any **Call key** on the MS-4002 to turn the beep feature ON or OFF. (It doesn't matter which one you tap, since this feature affects all channels.)
3. Tap the **Mic Kill** key to return to normal operation

---

## *Test Tone*

The MS-4002 can generate a test tone, which can be used to verify intercom channel operation after installation or to locate a malfunction. This test tone is also used for the sidetone adjustment.

To use the test tone, do the following:

1. Simultaneously press the **All Talk** and **PA** keys to activate the test tone.
2. Tap the **Call** key for the channel you want to test (can be either an MS-4002 channel or an EMS-4001 channel).
3. Verify the **test tone** can be heard at all intercom stations on the channel. Replace any defective cable or intercom station where the test tone is being lost.
4. Tap the same **Call** key to stop the test signal on that channel.
5. Press **any key** except a Call key to turn off the test tone.

---

## *Standard Programming*

Standard programming without entering program mode on the MS-4002

To enter Standard Programming, do the following:

1. Press and hold the **Mic Kill** key for about 2 seconds, then release it. It should now be glowing green to indicate that the intercom station is in programming mode..

**TABLE 7. Standard Programming Descriptions.**

---

<b>Description</b>	<b>Action</b>
Reset MS-4002	Press All Talk and Listen 1
Test Signal ON	Press All Talk and PA, then tap Call
Test Signal OFF	Tap Call, then tap any other key
Mic Latched ON	Tap Headset or Panel Mic (key is green)
Mic Latched OFF	Tap Headset or Panel Mic
Mic Momentary ON	Hold Headset or Panel Mic
Mic Momentary OFF	Release Headset or Panel Mic
VOX Mode ON	Tap Twice; Headset or Panel Mic (key is orange)
VOX Mode OFF	Tap Headset or Panel Mic
All Talk ON	Hold All Talk when Headset or Panel Mic is lit (All Talk key is green)
All Talk OFF	Release All Talk
Public Address	Hold PA when Headset or Panel Mic is lit (PA key is green)
Mic Kill, One Channel	Tap Mic Kill, then tap Talk or Listen (Mic Kill key will blink green and the Talk and Listen keys are green. Tap Mic Kill to exit.
Mic Kill, All Channels	Tap Mic Kill, then tap All Talk (Mic Kill key will blink green and all Talk/Listen keys are green). Tap Mic Kill to exit.
Program ON	Hold Mic Kill, then tap channel's Talk key (key is green). Tap Mic Kill to exit
Program OFF	Hold Mic Kill, then tap the channel's Talk key. Tap Mic Kill to exit.
Audible Call Alert ON	Hold Mic Kill, then tap Call (all Call keys are red). Tap the Mic Kill to exit
Audible Call Alert OFF	Hold Mic Kill, then tap Call. Tap Mic Kill to exit.
Turn Mic Kill Key OFF	Tap Mic Kill
Talk Latched ON	Tap Talk (key is green)
Talk Latched OFF	Tap Talk
Talk Momentary ON	Hold Talk
Talk Momentary OFF	Release Talk
Call Signal ON	Hold Call
Call Signal OFF	Release Call
Receive Call Signal	(Call key is red)
Listen Latched ON	Tap Listen (key is green)
Listen Latched OFF	Tap Listen
Listen Momentary ON	Hold Listen
Listen Momentary OFF	Release Listen

## Advanced Programming Using the MS-4002

Advanced Programming for the MS-4002 has moved from the Internal DIP switches (MS-2002 and previous models) to the front panel of the unit. Using Figure 8 you can program your MS-4002 with existing and new functionality.

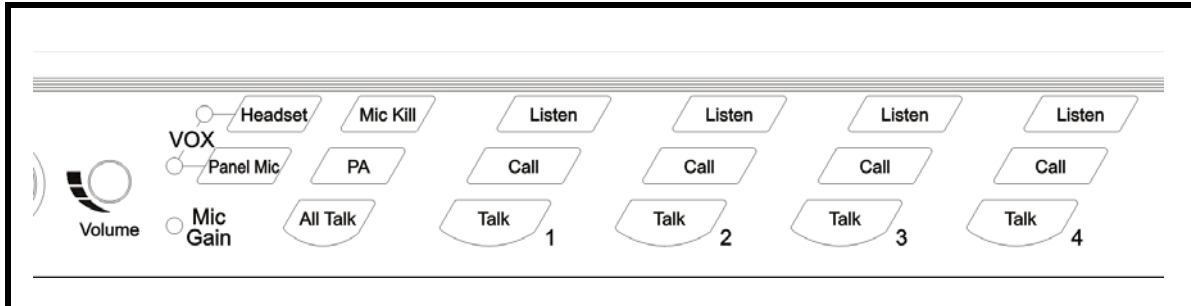

**Figure 8. Advanced Programming Buttons Diagram**

To access Advanced Programming Mode on the MS-4002, do the following:

1. Press and hold both **Mic Kill** and **PA** for five seconds.  
*After ten seconds of inactivity, the system will go back to Operation Mode.*

**NOTE:** A red and green flashing All Talk button signals operation in *Advanced Programming Mode*

Below, each programming function is described, as well as how to enable and disable the function

**NOTE:** You must be in the Advanced Programming Mode to perform the following configurations.

### Call Signal Send and Receive, Channel 1

The Call Signal Send and Call Signal Receive, Channel 1 function has been combined into one function that is enabled and disabled.

**Default Setting:** Call Signal Send and Receive, Channel 1 **enabled**.

To enable the Signal Send and Signal Receive for Channel 1, do the following:

1. Press **Channel 1 Call** button.  
*The button is backlit with a bright red light. The Signal Send and Signal Receive for Channel 1 is enabled.*

To disable the Signal Send and Signal Receive for Channel 1, do the following:

1. When lit red, press **Channel 1 Call** button.  
*The red back-light dims. The Signal Send and Signal Receive for Channel 1 is disabled.*

### Call Signal Send and Receive, Channel 2

The Call Signal Send and Call Signal Receive, Channel 2 function has been combined into one function that is enabled and disabled.

**Default Setting:** Call Signal Send and Receive, Channel 2 **enabled**.

To enable the Signal Send and Signal Receive for Channel 2, do the following:

1. Press **Channel 2 Call** button.  
*The button is backlit with a bright red light. The Signal Send and Signal Receive for Channel 2 is enabled.*

To disable the Signal Send and Signal Receive for Channel 2, do the following:

1. When lit red, press **Channel 2 Call** button.  
*The red back-light dims. The Signal Send and Signal Receive for Channel 2 is disabled.*

### Call Signal Send and Receive, Channel 3

The Call Signal Send and Call Signal Receive, Channel 3 function has been combined into one function that is enabled and disabled.

**Default Setting:** Call Signal Send and Receive, Channel 3 **enabled**.

To enable the Signal Send and Signal Receive for Channel 3, do the following:

1. Press button **Channel 3 Call** button.  
*The button is backlit with a bright red light. The Signal Send and Signal Receive for Channel 3 is enabled.*

To disable the Signal Send and Signal Receive for Channel 3, do the following:

1. When lit red, press button **Channel 3 Call** button.  
*The red back-light dims. The Signal Send and Signal Receive for Channel 3 is disabled.*

### Call Signal Send and Receive, Channel 4

The Call Signal Send and Call Signal Receive, Channel 4 function has been combined into one function that is enabled and disabled.

**Default Setting:** Call Signal Send and Receive, Channel 4 **enabled**.

To enable the Signal Send and Signal Receive for Channel 4, do the following:

1. Press **Channel 4 Call** button.  
*The button is backlit with a bright red light. The Signal Send and Signal Receive for Channel 4 is enabled.*

To disable the Signal Send and Signal Receive for Channel 4, do the following:

1. When lit red, press **Channel 4 Call** button.  
*The red back-light dims. The Signal Send and Signal Receive for Channel 4 is disabled.*

### Program Interrupt 1

**Default:** Program 1 Interrupt is **disabled**.

To enable Program 1 Interrupt, do the following:

1. Press **Channel 1 Talk** button.  
*The button is backlit with a bright green light. The Program 1 Interrupt is enabled.*

---

To disable the Program 1 Interrupt, do the following:

1. When lit green, press **Channel 1 Talk** button.  
*The green back-light dims. The Program 1 Interrupts disabled.*

## Program Interrupt 2

**Default:** Program 2 Interrupt is **disabled**.

To enable Program 2 Interrupt, do the following:

1. Press the **Channel 2 Talk** button.  
*The button is backlit with a bright green light. The Program 2 Interrupt is enabled.*

To disable the Program 2 Interrupt, do the following:

1. When lit green, press the **Channel 2 Talk** button.  
*The green back-light dims. The Program 2 Interrupt is disabled.*

## Program Interrupt 3

**Default:** Program 3 Interrupt is **disabled**.

To enable Program 3 Interrupt, do the following:

1. Press the **Channel 3 Talk** button.  
*The button is backlit with a bright green light. The Program 3 Interrupt is enabled.*

To disable the Program 3 Interrupt, do the following:

1. When lit green, press the **Channel 3 Talk** button.  
*The green back-light dims. The Program 3 Interrupt is disabled.*

## Program Interrupt 4

**Default:** Program 4 Interrupt is **disabled**.

To enable Program 4 Interrupt, do the following:

1. Press the **Channel 4 Talk** button.  
*The button is backlit with a bright green light. The Program 4 Interrupt is enabled.*

To disable the Program 4 Interrupt, do the following:

1. When lit green, press the **Channel 4 Talk** button.  
*The green back-light dims. The Program 4 Interrupt is disabled.*

## Incoming Call Beep, Headset

**Default:** Incoming Call Beep, Headset **Enabled (ON)**

To enable the Incoming Call Beep, do the following:

1. Press the **Headset** button.  
*The key is backlit with a bright red light. Incoming Call Beep, Headset is enabled.*

To disable the Incoming Call Beep, Headset, do the following:

1. When lit red, the **Headset** button.

*The key is backlit with a dim green light. Incoming Call Beep, Headset is disabled.*

### **Incoming Call Beep, Panel Speaker**

**Default:** Incoming Call Beep, Panel Speaker **Enabled (ON)**

To enable the Incoming Call Beep, do the following:

1. Press the **Panel Mic** button.

*The key is backlit with a bright red light. Incoming Call Beep, Panel Speaker is enabled.*

To disable the Incoming Call Beep, Panel Speaker, do the following:

2. When lit red, the **Panel Mic** button.

*The key is backlit with a dim green light. Incoming Call Beep, Panel Speaker is disabled.*

### **Listen 2 to Speaker 1**

**Default:** Listen 2 to Speaker 1 **disabled (OFF)**

To enable Listen 2 to Speaker 1, do the following:

1. Press the **Channel 2 Listen** button.

*The key is backlit with a bright green light. Listen 2 to Speaker 1 is enabled.*

To disable the Listen 2 to Speaker 1, do the following:

1. Press the **Channel 2 Listen** button.

*The green back-light dims. Listen 2 to Speaker 1 is disabled.*

### **Listen 3 to Speaker 1**

**Default:** Listen 3 to Speaker 1 **disabled (OFF)**

To enable Listen 3 to Speaker 1, do the following:

1. Press the **Channel 3 Listen** button.

*The key is backlit with a bright green light. Listen 3 to Speaker 1 is enabled.*

To disable the Listen 3 to Speaker 1, do the following:

1. Press the **Channel 3 Listen** button.

*The green light dims. Listen 3 to Speaker 1 is disabled.*

### **Listen 4 to Speaker 1**

**Default:** Listen 4 to Speaker 1 **disabled (OFF)**

To enable Listen 4 to Speaker 1, do the following:

1. Press the **Channel 4 Listen** button.

*The key is backlit with a bright green light. Listen 4 to Speaker 1 is enabled.*

To disable the Listen 4 to Speaker 1, do the following:

1. Press the **Channel 4 Listen** button.

*The green back-light dims. Listen 4 to Speaker 1 is disabled.*

# Specifications

## General

### Power Requirements

#### AC Input:

100-240 VAC, 50/60 Hz

#### Channel Power:

24VDC nominal (12 - 30 VDC), up to 1 Amp per channel (max. 3.5 Amps)

### Dimensions

1.75" (44.5mm)high x 19" (483 mm) wide x 11.25" (286 mm) deep

### Weight

approximately 5lb. (2.25 kg)

### Environmental Requirements

#### Storage:

-20° C to 80°C; 0% to 95% humidity, non-condensing

#### Operating

-15° C to 60° C; 0% to 95% humidity, non-condensing

## Dynamic/Electret Mic Headset

### Microphone

50-200 Ohm, dynamic (balanced or unbalanced) - 2k Ohm, electret

### Headphones

150-600 Ohm, monaural

### Connector Type

XLR-4M connector

### Input Level

-55 dBu (nominal), dynamic  
9 mV, electret

## Panel Microphone: Input

### Microphone Type

Electret condenser (MCP-90 series microphone)

### Power

Phantom (+12 VDC)

### Nominal Level

-42 dBu

### Maximum Level

-25 dBu

### Connector Type

1/4" stereo plug with threaded shaft

## Program Input

### Input Level

100 mV maximum

### Voltage Gain

20 ± 3 dB

### Output Level (to intercom channel)

1.0 Vrms nominal, 2.3 Vrms max.

### Input Impedance

75 k Ohm

### Common Mode Rejection

Greater than 50 dB

### Connector Type

9-pin female D-sub (DE9S)

Pin 1	Ground
Pin 2	Program 1 input low
Pin 3	Program 2 input low
Pin 4	Program 3 input low
Pin 5	Program 4 input low
Pin 6	Program 1 input high
Pin 7	Program 2 input high
Pin 8	Program 3 input high
Pin 9	Program 4 input high

## Input Channels, Balanced Mode

### Output Level

1 Vrms nominal

### Input Impedance

300 Ohms

### Bridging Impedance

Greater than 10,000 Ohms

### Sidetone

-40 dB, 35 dB adjustable range

### Call Signaling

#### Send:

20 kHz ± 100 Hz 0.5 Vrms ± 10%

#### Receive:

20 kHz ± 800 Hz, 100 mVrms

### Mic Kill Frequency

#### Send

24 kHz ± 100 Hz, 0.5 Vrms ± 10%

#### Receive

24 kHz ± 800 Hz, 100 mVrms

### Noise Contribution

Less than -70dB

### Common Mode Rejection Ratio

Greater than 50 dB

### Connector Type

One XLR-3M and XLR -3F pair, wired in parallel, for each channel (permits "loop-through" connection). Four total channels.

Pin 1	Common
Pin 2	Intercom audio low and +24 VDC input
Pin 3	Intercom audio high and +24 VDC input

## Intercom Channel, Unbalanced Mode

### Output Level

.750 Vrms ± 10%

### Input Impedance

200 Ohms

### Bridging Impedance

Greater than 10,000 Ohms

### Call Signaling

#### Send

11 ±3 VDC

#### Receive

4 VDC minimum

### Connector Type

Uses the same connectors as balanced mode, above, but with pin-out modified by BAL/UNBAL switch on back panel as follows:  
XLR-3 Unbalanced Configuration Pin-out

Pin 1	Common
Pin 2	+30 VDC input
Pin 3	Intercom audio high

**PA Output**

Output Level

235 mV nominal

Connector Type

3.5 mm Stereo Phone Jack

Tip:	PA output high
Ring:	Not Used
Sleeve:	Common

**Speaker Output**

Output Level

0 dBU nominal (1.0 Vrms max)

Output Impedance

1000 Ohms

Frequency Response

200 Hz to 8 kHz +1/-3 dB

Connector Type

RCA Phono Jack

Tip:	Speaker output high
Sleeve:	Common

**Expansion Input/Output**

Type

3.5 mm Stereo Phono Jack

Tip:	Talk output
Ring:	Listen input
Sleeve:	Common





*12000 Portland Avenue South • Burnsville, Minnesota • 55377 • U.S.A.*

*Phone: (800) 392-3497 • Fax: (800) 323-0498*

*[www.telex.com](http://www.telex.com)*

---