

*Model PS-2001L
Power Supply*

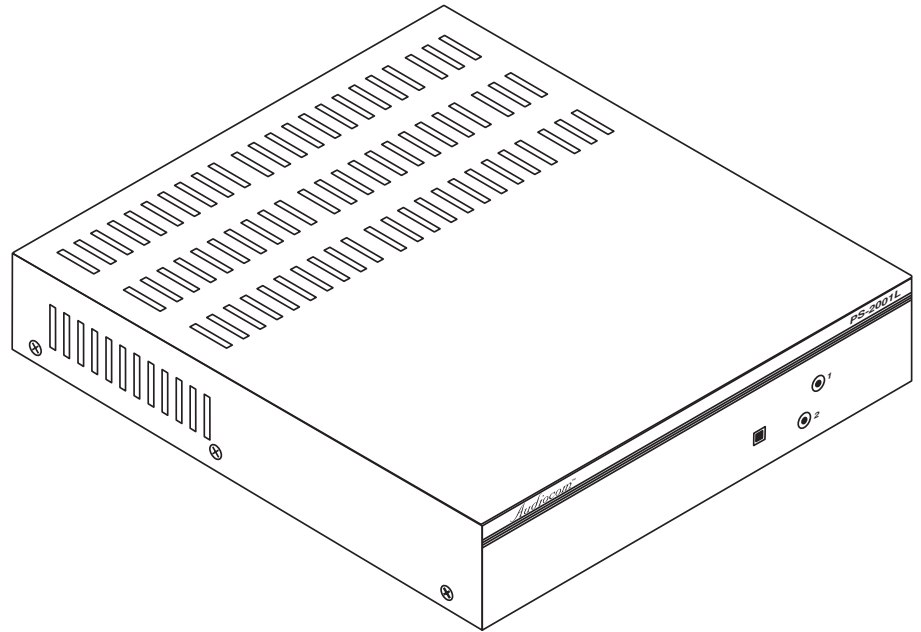

*Model SPS-2001
Power Supply*

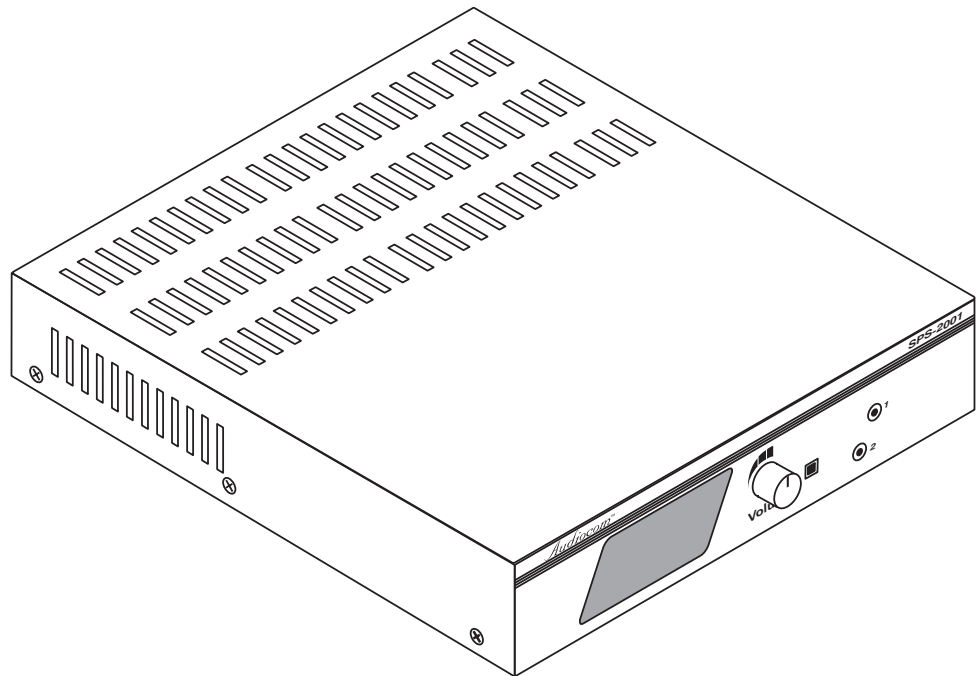

PROPRIETARY NOTICE

The product information and design disclosed herein were originated by and are the property of Telex Communications, Inc. Telex reserves all patent, proprietary design, manufacturing, reproduction, use and sales rights thereto, and to any article disclosed therein, except to the extent rights are expressly granted to others.

COPYRIGHT NOTICE

Copyright 2006 by Telex Communications, Inc. All rights reserved. Reproduction, in whole or in part, without prior written permission from Telex is prohibited.

WARRANTY NOTICE

See the enclosed warranty card for further details.

CUSTOMER SUPPORT

Technical questions should be directed to:

Customer Service Department
RTS/Telex Communications, Inc.
12000 Portland Avenue South
Burnsville, MN 55337 USA
Telephone: 800-392-3497
Fax: 800-323-0498
Factory Service: 800-553-5992

RETURN SHIPPING INSTRUCTIONS

Customer Service Department
Telex Communications, Inc. (Lincoln, NE)
Telephone: 402-467-5321
Fax: 402-467-3279
Factory Service: 800-553-5992

Please include a note in the box which supplies the company name, address, phone number, a person to contact regarding the repair, the type and quantity of equipment, a description of the problem and the serial number(s).

SHIPPING TO THE MANUFACTURER

All shipments of product should be made via UPS Ground, prepaid (you may request from Factory Service a different shipment method). Any shipment upgrades will be paid by the customer. The equipment should be shipped in the original packing carton. If the original carton is not available, use any suitable container that is rigid and of adequate size. If a substitute container is used, the equipment should be wrapped in paper and surrounded with at least four (4) inches of excelsior or similar shock-absorbing material. All shipments must be sent to the following address and must include the Proof of Purchase for warranty repair. Upon completion of any repair the equipment will be returned via United Parcel Service or specified shipper, collect.

Factory Service Department
Telex Communications, Inc.
8601 East Cornhusker Hwy.
Lincoln, NE 68507 U.S.A.
Attn: Service

This package should include the following:

PS-2001L		
Qty.	Description	Part No.
1	PS-20001L Final Assembly	9010-7699-001
1	User Manual	9350-7699-000
1	Warranty Statement	38110-390
4	Rubber Feet	56471-001
1	Power Cord, Black	2504-0003-00
1	Statement of Conformity	38109-675
SPS-2001		
1	PS-20001L Final Assembly	9010-7699-001
1	User Manual	9350-7699-000
1	Warranty Statement	38110-390
4	Rubber Feet	56471-001
1	Power Cord, Black	2504-0003-00
1	Patch Cord	50628-003
1	Statement of Conformity	38109-675

FCC STATEMENT

This equipment uses, and can radiate radio frequency energy that may cause interference to radio communications if not installed in accordance with this manual. The equipment has been tested and found to comply with the limits of a Class A computing device pursuant to Subpart J, Part 15 of FCC Rules which are designed to provide reasonable protection against such interference when operated in a commercial environment. Operation of this equipment in a residential area may cause interference which the user (at his own expense) will be required to correct.

 This product meets Electromagnetic Compatibility Directive 89/336/EEC.

TABLE OF CONTENTS

Introduction 3
Description 3

Installation 7
Configuration Switches 7
Intercom Channel and Program Connections 7
Channel Capacity: 7
Audiocom Connections: 7
Clear-Com Applications: 7
Desktop or Rackmount Installation 7
Power-Up Check 13
Specifications 13

Description

The PS-2001L and SPS-2001 are versatile power supplies that can be used in a variety of Audiocom[®] intercom system applications. They both directly accept any AC input power from 100 to 240 VAC, 50/60 Hz and can be configured to power two separate intercom channels or one large intercom channel with twice the intercom station capacity. Additionally, the units can be configured for compatibility with Clear-Com[®] Intercom Systems. The units may be rack mounted or used on a desktop. For rack mounting, optional hardware is required. For desktop use, four non-marring rubber feet are supplied. The SPS-2001 also provides a speaker with two mixed inputs making it ideal for situations calling for a master station with a microphone/speaker combination.

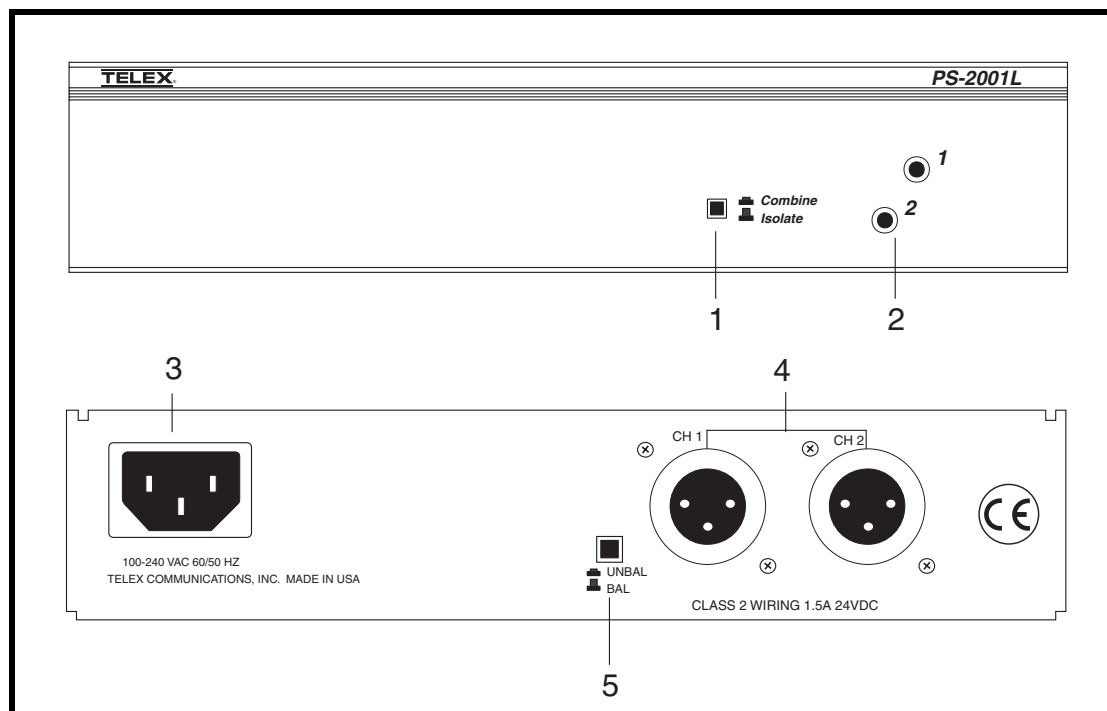

FIGURE 1. PS-2001L Front and Rear Panel Features

1. **Combine/Isolate Switch:** When in the Combine position, the unit will combine the audio signals of the two channels to create a single audio channel where all users can intercommunicate. When in the Isolate position, the unit will create two groups of completely independent users.
2. **Channel Status Indicators:** The indicators are green for normal operation and red when there is an overload or short circuit. The circuitry in the unit will automatically reset when the overload or short circuit is located and fixed.
3. **Universal AC Power Input:** The unit accepts any input power in the range of 100-240 VAC, 50/60 Hz.
4. **Intercom Channel Connectors:** When the Combine/Isolate switch is set to the Isolate position, each channel connector is powered separately and has completely separate intercom audio. When the Combine/Isolate switch is set to the Combine position, each channel is still powered separately, but the audio signals are combined so that all users on both channels can intercommunicate.
5. **BAL/UNBAL Selector Switch:** This selector switch allows the user to configure the unit for use in either an Audicom[®] (BALANCED) or Clear-Com (UNBALANCED) system. Compatibility includes channel connector pin-outs, channel power requirements, and call signaling requirements. The default setting for this switch is in the Audicom[®] (BAL) position.

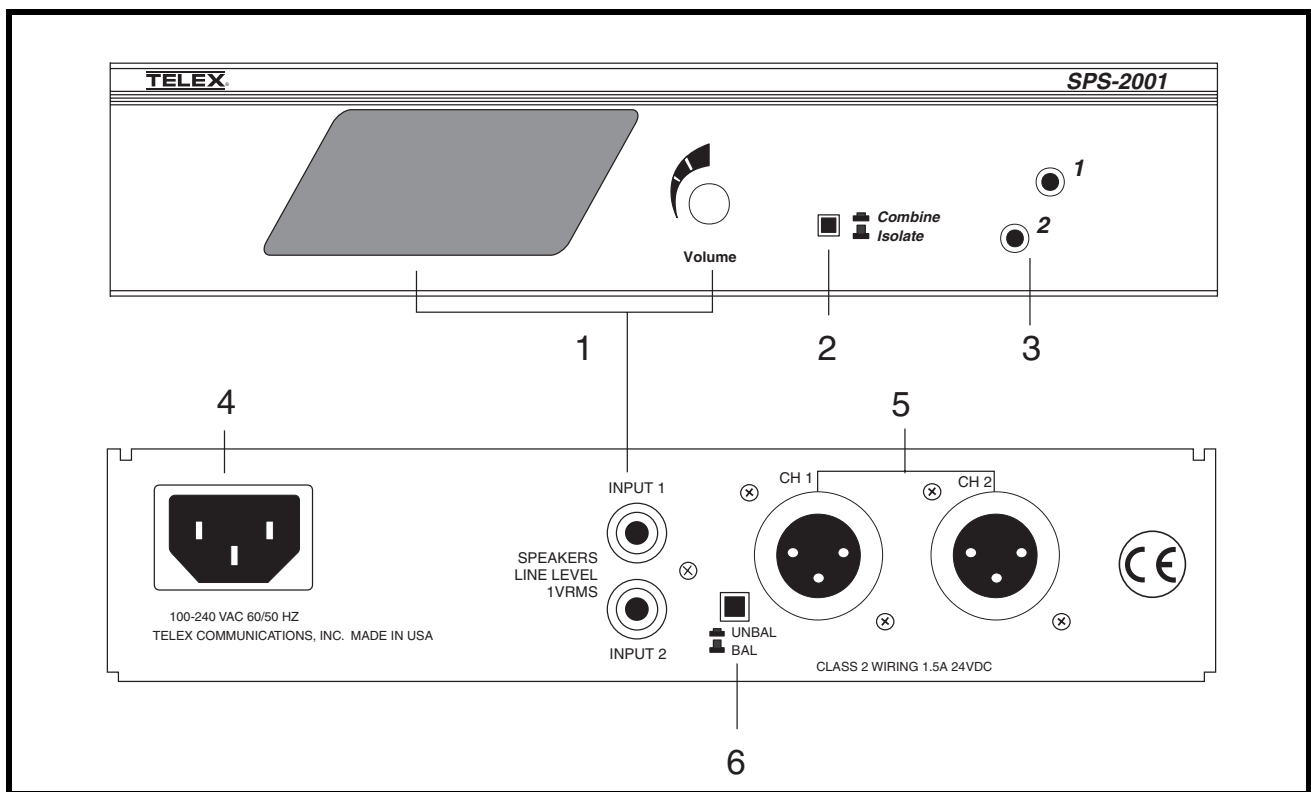

FIGURE 2. SPS-2001 Front and Rear Panel Features

1. **Speaker, Inputs, and Volume Control:** Two audio inputs are provided. The inputs are combined internally and set as a monaural signal to the internal speaker amplifier. The Volume control adjusts the level to the front panel speaker. Typically, these inputs are used with the speaker outputs of a master station when the master station is set for use with a panel microphone and speaker instead of a headset.
2. **Combine/Isolate Switch:** When in the Combine position, the unit will combine the audio signals of the two channels to create a single audio channel where all users can intercommunicate. When in the Isolate position, the unit will create two groups of completely independent users.
3. **Channel Status Indicators:** The indicators are green for normal operation and red when there is an overload or short circuit. The circuitry in the unit will automatically reset when the overload or short circuit is located and fixed.
4. **Universal AC Power Input:** The unit accepts any input power in the range of 100-240 VAC, 50/60 Hz.

Description

5. Intercom Channel Connectors: When the Combine/Isolate switch is set to the Isolate position, each channel connector is powered separately and has completely separate intercom audio. When the Combine/Isolate switch is set to the combine position, each channel is still powered separately, but the audio signals are combined so that all users on both channels can intercommunicate.
6. BAL/UNBAL Selector Switch: This selector switch allows the user to configure the unit for use in either an Audiocom[®] (BALANCED) or Clear-Com (UNBALANCED) system. Compatibility includes channel connector pin-outs, channel power requirements, and call signaling requirements. The default setting for this switch is in the Audiocom[®] (BAL) position.

Configuration Switches

The BAL/UNBAL switch (located on the rear of the unit) is set to the Balanced (Audiocom) position when the unit is shipped from the factory. To set the switch to the Unbalanced (Clear-Com) mode, use a pointed object such as a pen to push in the switch.

The Combine/Isolate switch (located on the front of the unit) can be changed at any time by using a pointed object such as pen to push in the switch. When the switch is in the Combine position, all users on both channels may intercommunicate. When the switch is set to the Isolate position, channels 1 and 2 cannot intercommunicate.

Intercom Channel and Program Connections

Channel Capacity:

When connecting intercom stations to the PS-2001L or SPS-2001, determine the total current for all stations on each channel. The total per channel should not exceed 2A. If you exceed this limit, an overload indication will be provided and the output of the power supply will be turned OFF. Once the overload is corrected, the overload indications will disappear and the power supply output will be turned ON. Note, if you are using DC wallpacks with some intercom stations, you do not need to add the current consumption of those stations to the total current.

Audiocom Connections:

Intercom cable wiring details are shown in figure X. Speaker and interconnection cables (SPS-2001 Only) are standard RCA phono types. For program input cable wiring, refer to your master intercom station user manual. Some typical applications are shown in the figures on page 9.

Clear-Com Applications:

Refer to your Clear-Com system documentation for intercom cable wiring and connection details.

Desktop or Rackmount Installation

For desktop use, install the four supplied rubber feet to the bottom of the unit. Do not obstruct the cooling vents when using the unit on a desktop.

For rack mounting, use an optional Audiocom Rackmount Kit. Several kits are available to meet the requirements of your particular system. Follow the assembly instructions supplied with the rack mount kit.

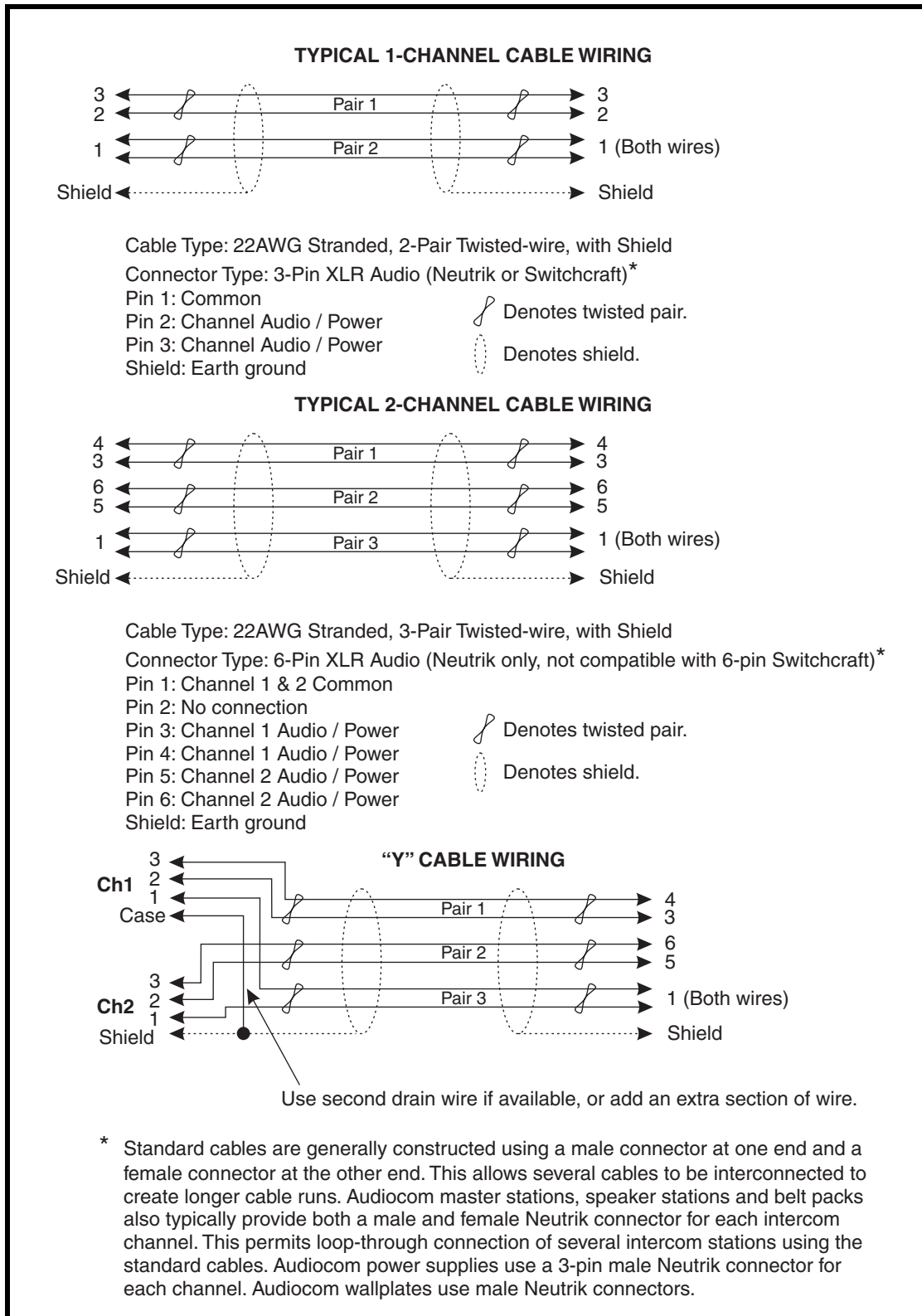

FIGURE 3. Cable Wiring Diagrams for Audiocom Applications

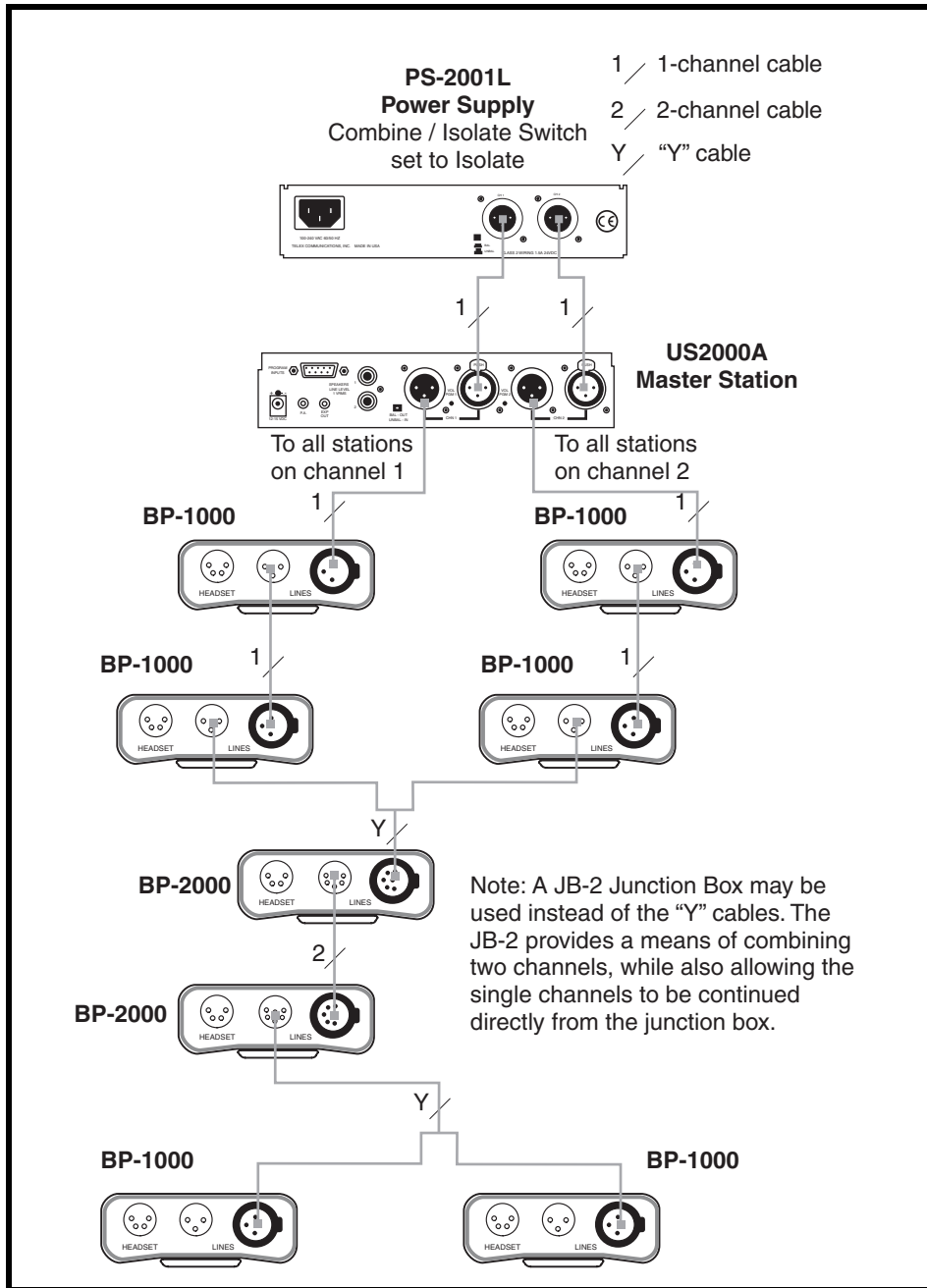

FIGURE 4. Typical connections using a single PS-2001L Power Supply to power two channels.

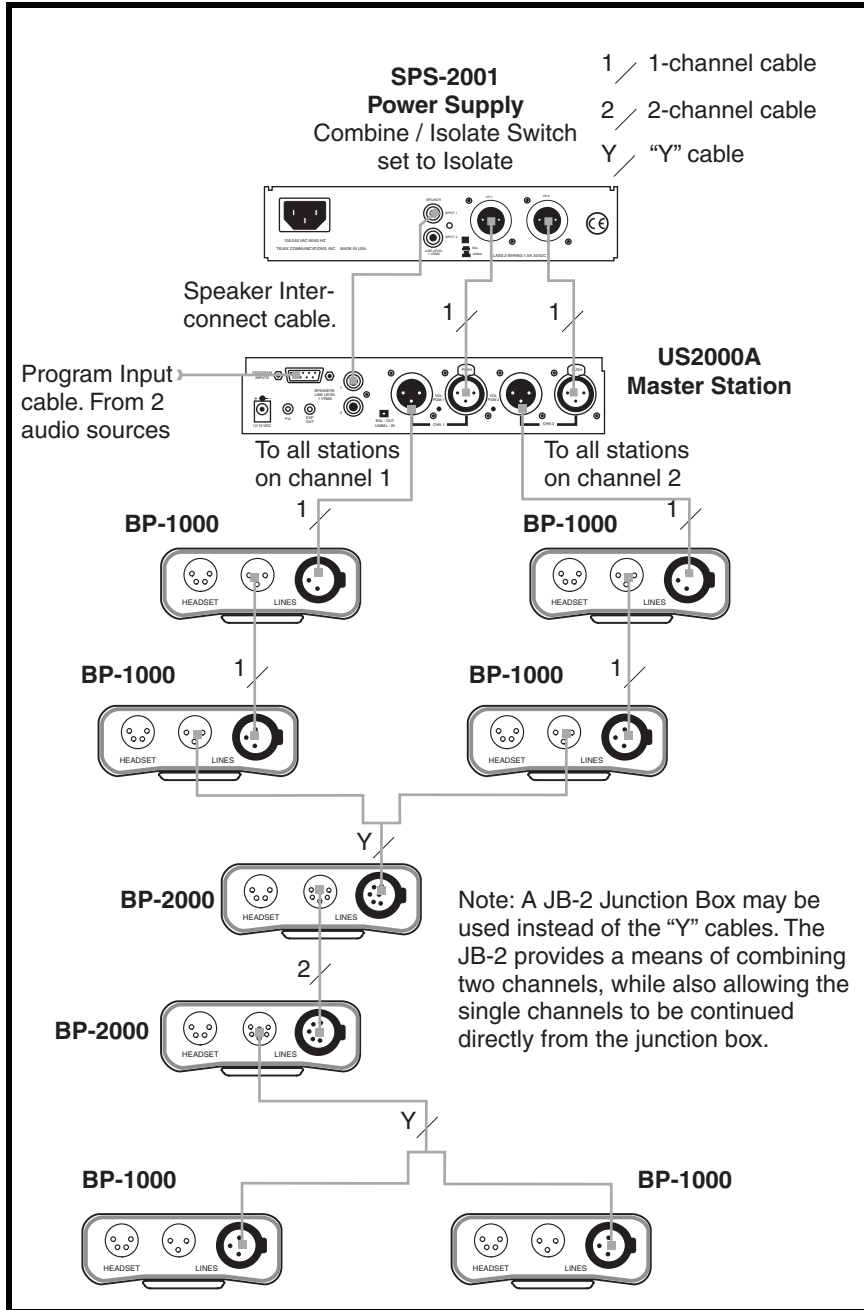

FIGURE 5. Typical connections using an SPS-2001 Power Supply for two intercom channels. The two program sources are monitored independently by their intercom channels. All audio (program and intercom) is monitored as a monaural mix in the SPS-2001 speaker. The US2000A is set for monaural speaker output (default).

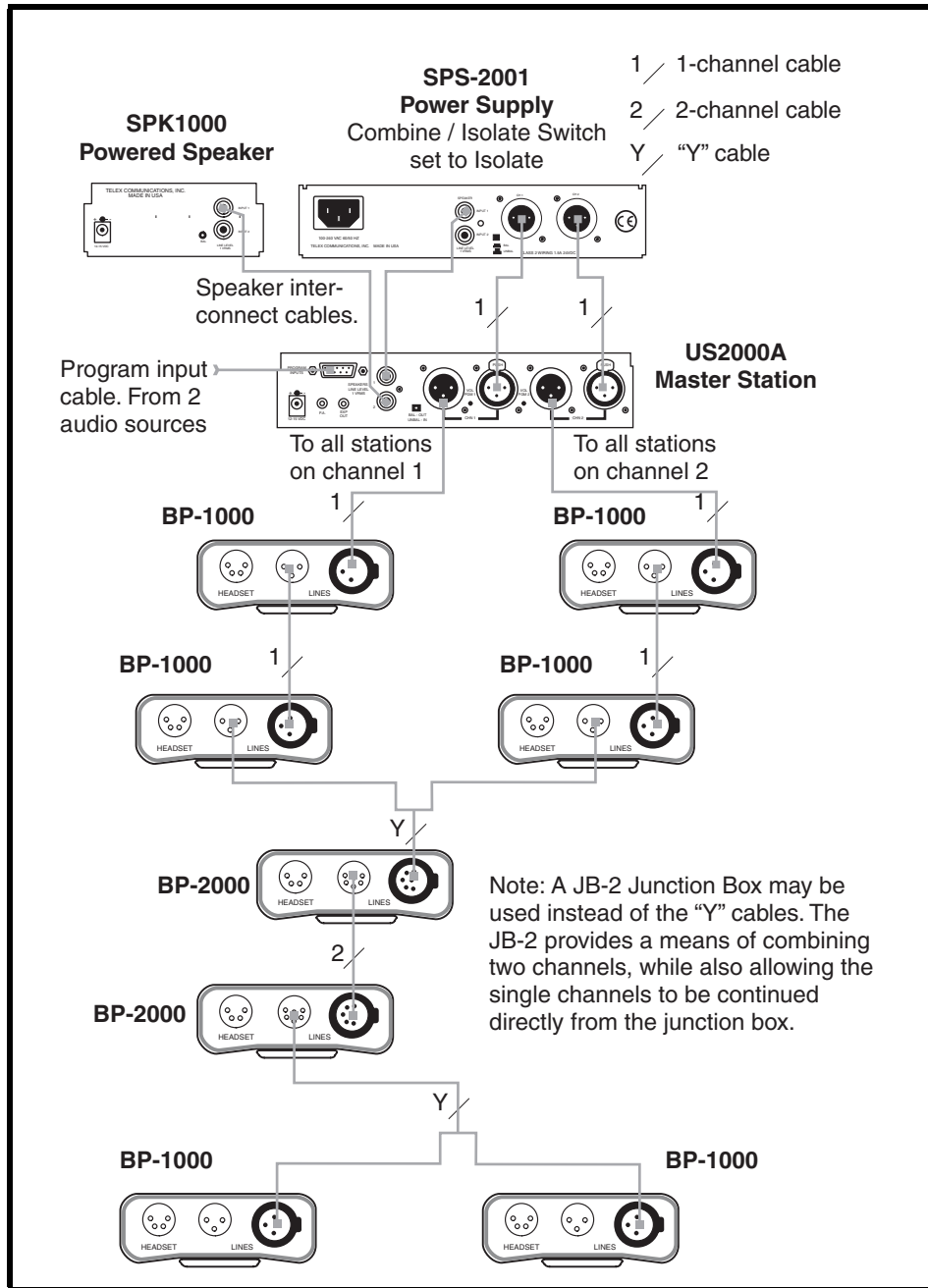

FIGURE 6. Adding an SPK-1000 to the example in Figure X. The two program sources are monitored independently by the intercom channels. The SPS-2001 monitors intercom channel 1 and program 1. The SPK-1000 monitors intercom channel 2 and program 2. The US2000A is sent for binaural speaker output as described in the US2000A User Manual.

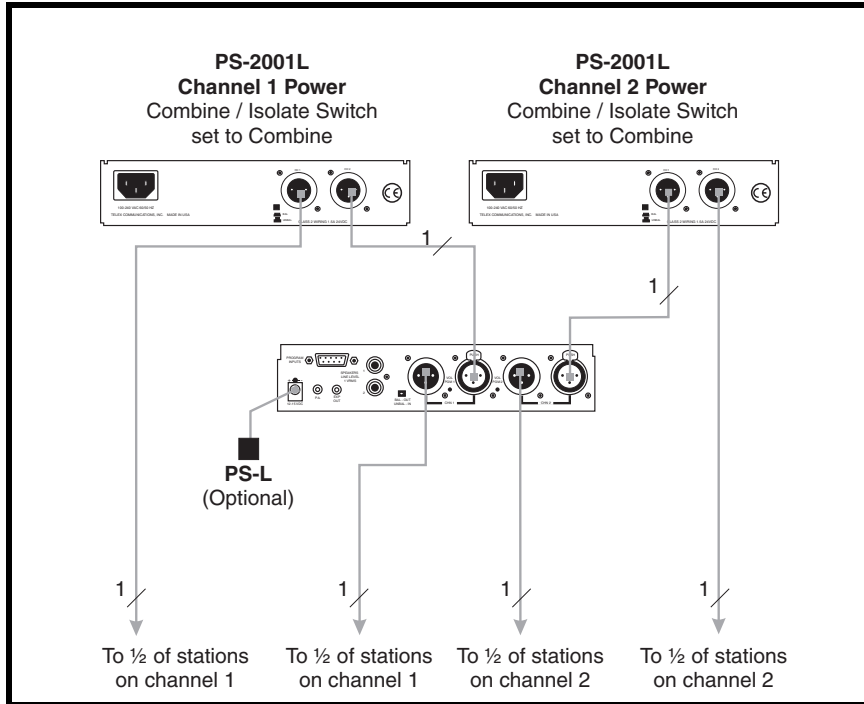

FIGURE 7. Using two PS-2001L Power Supplies to provide a greater capacity on each channel.

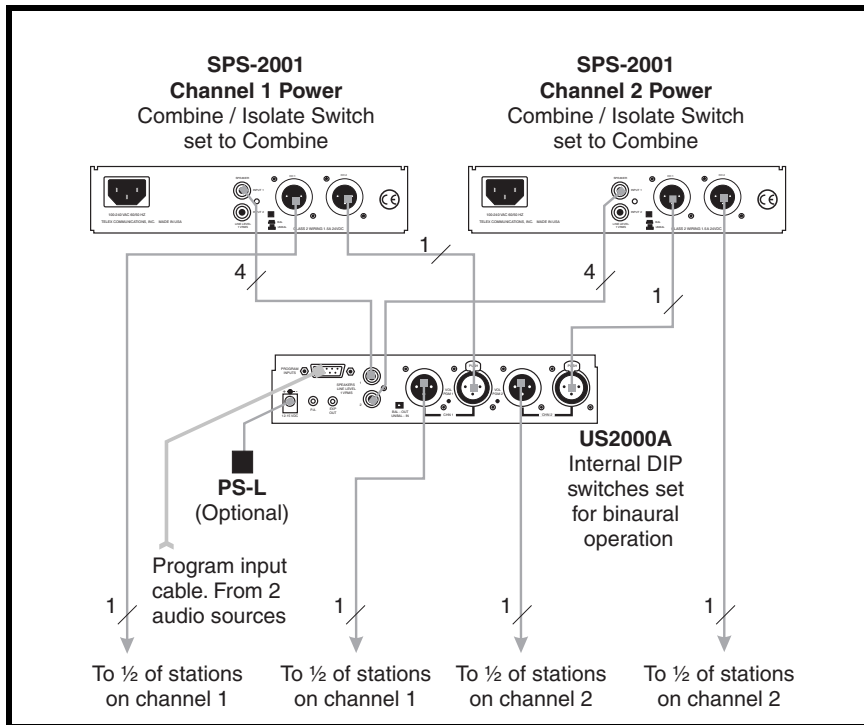

FIGURE 8. Using two SPS-2001 Power Supplies to provide a greater capacity on each channel. Using two SPS-2001 Power Supplies also lets you independently monitor and adjust volume for both intercom channels without the need for a separate powered loudspeaker. In this application, the US-2000A should be set for binaural speaker output as described in the US2000A manual.

Power-Up Check

1. Plug in any DC wallpacks that are being using with individual intercom stations.

NOTE: If you plug in DC wallpacks after applying power to the PS2001L or SPS-2001, you may get an overload indication. This is because the stations that are being powered by wallpacks will draw current from the units until their own DC wallpack supplies are connected. To correct the problem, plug in the DC wallpacks.

2. Plug in the AC power cords for any connected PS-2001L or SPS-2001 Power Supplies. The channel status indicators should be green.
3. If a channel status indicator turns red during operation, locate the short or overload that is causing the problem. Once the short or overload is corrected, the Power Supply should reset itself and the overload indication should go away.

Specifications

General

Input Power Requirements

100 to 240 VAC, 50/60 Hz

Output Power (each channel)

21 ±1 VDC, 1 Amp per channel

Dimensions

1.75" (44.5 mm) high x 8.25" (209.5mm) wide x 10.31" (261.9mm) deep

Weight

approximately 2.5 lb. (1.13 kg.)

Environmental Requirements

Storage:

-20° C to 80° C, 0% to 95% humidity, non-condensing

Operating:

0° C to 50° C, 0% to 95% humidity, non-condensing

Intercom Channels (General)

Connector Type:

One XLR-3M audio connector for each channel. Pin-out depends on setting of BAL/UNBAL switch for balanced or unbalanced operation as defined below:

Balanced Mode (set to BAL position)

Line Terminating Impedance: 300 ohms ±10%

Connector Pinout

- Pin 1 Common (audio and DC return)
- Pin 2 Full-duplex, balanced intercom audio and +24 VDC output
- Pin 3 Full-duplex, balanced intercom audio and +24 VDC output

Unbalanced Mode (set to UNBAL position)

Line Terminating Impedance: 150 ohms ±5%

Connector Pin-out:

- Pin 1 Common (audio and DC return)
- Pin 2 +24 VDC output
- Pin 3 Full-duplex, unbalanced intercom audio high

Speaker Inputs (SPS-2001 only)

Type:

RCA Phone Jack

Tip: Speaker + Input

Sleeve: Speaker - Input

Approvals

UL, CUL, CE

