

**Martin**<sup>®</sup>

# Inground 200<sup>™</sup>

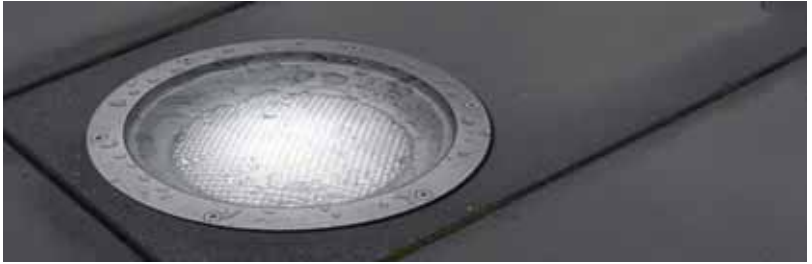

## User Manual

Full Spectrum CMY

# Dimensions

Measurements are in millimeters

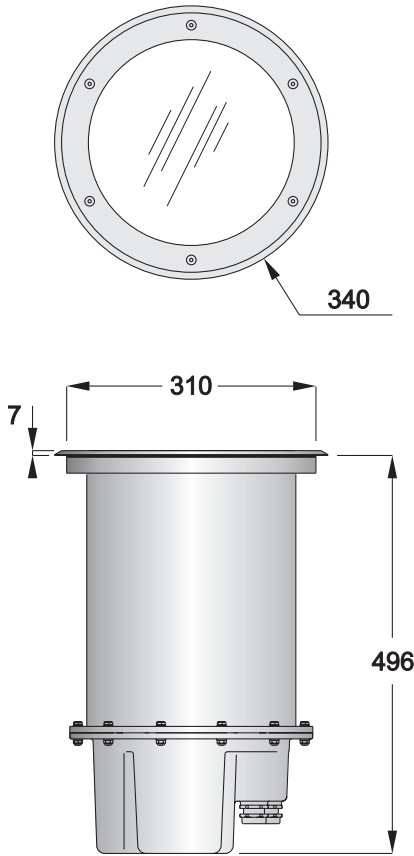

© 2004-2008 Martin Professional A/S. Information subject to change without notice. Martin Professional A/S and all affiliated companies disclaim liability for any injury, damage, direct or indirect loss, consequential or economic loss or any other loss occasioned by the use of, inability to use or reliance on the information contained in this manual. The Martin logo, the Martin name and all other trademarks in this document pertaining to services or products by Martin Professional A/S or its affiliates and subsidiaries are trademarks owned or licensed by Martin Professional A/S or its affiliates or subsidiaries.

P/N 35000153, Rev C

**Martin**<sup>®</sup>

- Section 1. Getting started** ..... 7
  - Introduction** ..... 7
    - Inground 200 model range ..... 7
    - Optics and accessories ..... 7
    - Mains power options ..... 8
    - Included items ..... 8
  - Safety information** ..... 8
  - General operation** ..... 10
    - General guidelines ..... 10
    - Understanding shows and scenes ..... 10
    - Powering on for the first time ..... 11
    - Control and programming options ..... 11
    - Initial configuration for use ..... 12
    - Defining fixture settings using MUM ..... 14
    - Defining fixture settings using an MP-2 ..... 17
- Section 2. Stand-Alone operation** ..... 21
  - Stand-alone programming overview** ..... 21
    - About scene timing ..... 22
    - Synchronizing scene changes for multiple fixtures ..... 22
    - Programming methods ..... 23
  - Programming from a PC using MUM** ..... 23
    - Getting started with MUM ..... 24
    - Stand-Alone Settings ..... 24
    - Programming effects in scenes ..... 26
    - Programming the same stand-alone show on multiple fixtures ..... 28
  - Programming using an MP-2 Uploader** ..... 29
    - Getting started ..... 29
    - Selecting fixtures to program ..... 30
    - Enabling or disabling stand-alone mode ..... 31
    - Synchronizing scene changes for multiple fixtures ..... 31
    - Automatically triggering stand-alone operation ..... 33
    - Programming effects in scenes ..... 33
    - Disconnecting the MP-2 Uploader ..... 35
  - Stand-Alone show playback** ..... 35
    - Starting show playback automatically at fixture power-on ..... 35
    - Scene execution using the optional MC-X ..... 35

DMX controller override during stand-alone show playback . . . . .	36
<b>Synchronous triggering during Stand-Alone operation . . . . .</b>	<b>37</b>
<b>Section 3. DMX control . . . . .</b>	<b>39</b>
<b>DMX Controller operation . . . . .</b>	<b>39</b>
Lamp control . . . . .	39
Effects . . . . .	40
<b>Section 4. Optics . . . . .</b>	<b>41</b>
<b>Color matching with other fixtures . . . . .</b>	<b>41</b>
<b>Section 5. Service and troubleshooting . . . . .</b>	<b>43</b>
<b>Service procedures . . . . .</b>	<b>43</b>
Clearing excess humidity . . . . .	44
Cleaning . . . . .	44
Seals . . . . .	45
<b>Component removal &amp; reinstallation . . . . .</b>	<b>46</b>
<b>Set-up and adjustment . . . . .</b>	<b>55</b>
Beam adjustment . . . . .	55
<b>Firmware updates . . . . .</b>	<b>57</b>
<b>Printed circuit board layout . . . . .</b>	<b>60</b>
<b>Troubleshooting . . . . .</b>	<b>61</b>
<b>Section 6. Reference . . . . .</b>	<b>63</b>
<b>MP-2 control menu structure . . . . .</b>	<b>63</b>
<b>DMX protocol: Inground 200 CMY . . . . .</b>	<b>66</b>
<b>Specifications: Inground 200 CMY . . . . .</b>	<b>67</b>
<b>Ordering information . . . . .</b>	<b>70</b>

# SECTION 1. GETTING STARTED

## 1. Introduction

Thank you for selecting the Martin™ Inground 200™ Full Spectrum CMY, an intelligent 150 watt uplight designed for permanent burial installation.

This User Manual contains details of how to *operate and service* this fixture. For details of *installing* the Inground 200 CMY, please refer to the Installation Guide shipped with the product. The most recent versions of the Installation Guide and this User Manual are also available in the Product Support area of the Martin website at <http://www.martin.com>

### Inground 200 model range

---

The Inground 200 is available in two models:

#### Inground 200 Single Color

The Inground 200 Single Color can be operated with or without a color filter and can be manually dimmed, but it is not programmable and cannot be controlled by DMX. A separate user manual, P/N 35000152, exists for this product.

#### Inground 200 CMY

The Inground 200 Full Spectrum CMY offers seamless full spectrum color-mixing, giving a virtually limitless color palette, and 0-100% intensity control. It can be programmed to run synchronized stand-alone light shows with pre-defined start/stop times using a Windows PC with Martin MUM™ software, or it can be operated using a DMX controller.

### Optics and accessories

---

The following optional lenses are available for the Inground 200:

- Medium – 32° one-tenth peak angle
- Wide – 56° one-tenth peak angle
- Very wide – 98° one-tenth peak angle
- Wallwash

A range of accessories is available for the Inground 200. See “*Ordering information*” on page 68. See also [www.martin.com](http://www.martin.com) for the most recent information.

## Mains power options

---

Inground 200 Single Color and CMY models are both available in three configurations to match local AC mains power:

- 210 V, 60 Hz (US model)
- 277 V, 60 Hz (US model)
- 230 V, 50 Hz (EU model)

## Included items

---

The Inground 200 CMY is supplied with the following items:

- Philips CDM-SA/T 150W/942 lamp
- Silica gel sachet inside fixture for shipping (must be removed and disposed of)
- Silica gel sachet packed separately in sealed aluminum bag (must be fastened inside fixture and fixture closed within 20 minutes of opening aluminum bag)
- DMX termination resistor
- 3 m (9.8 ft.) hard-wired power cable tail
- 3 m (9.8 ft.) hard-wired control data in/out cable tail
- Installation guide
- User manual

# 2. Safety information

**Warning!** *This product is not for household use.*

This product presents risks of lethal or severe injury due to fire, heat, electric shock and lamp explosion.

**Read this guide** before operating the fixture, follow the safety precautions listed below and observe all warnings in this guide and on the fixture.

If you have questions about how to operate or service the fixture safely, please contact your Martin supplier or call the Martin 24-hour service hotline on +45 8740 0000, or in the USA on 1-888-tech-180.

## Guarding against electric shock

- Isolate the fixture from AC power before removing or installing the lamp, fuses, or any part.
- Always ground (earth) the fixture electrically.
- Use only a source of AC power that complies with local building and electrical codes and has both overload and ground-fault protection.
- Refer any service not described in this user manual to a Martin service technician.

## Lamp safety and eye protection

- Never operate the fixture with missing or damaged lenses and/or covers.
- Do not stare directly into the light. Never look at an exposed lamp while it is lit.
- Wear safety glasses during beam adjustment.
- Use only approved lamp types (see “*Source*” on page 65).
- Replace the lamp if it becomes defective or worn out. The average life of the Philips CDM-SA/T 150W/942 lamp supplied with the Inground 200 CMY is 9000 hours. If one of the approved alternative lamp types listed under “*Source*” on page 65 is fitted, see the lamp supplier’s documentation.

## Guarding against burns and fire

- Allow the fixture to cool for at least 15 minutes after use before opening it for service or adjustment.
- Wear heat-resistant safety gloves during beam adjustment.
- Never attempt to bypass the thermostatic switch or fuses. Always replace defective fuses with ones of the specified type and rating.
- Keep all combustible materials (for example fabric, wood, paper) at least 1 meter (39 inches) away from the fixture. Keep flammable materials well away from the fixture.
- Ensure that litter, dry leaves or other combustible materials cannot accumulate on or near the fixture.
- Prevent vehicles from being parked over or near fixtures – including unlit fixtures that may later be switched on.
- Do not illuminate surfaces within 0.5 meters (20 inches) of the fixture.
- Install the fixture outdoors or in a well ventilated area.
- The exterior of the fixture can become very hot, up to 80° C (176° F) during normal operation. Ensure all local safety regulations and legal requirements are observed, and take appropriate measures to warn or restrict access.
- Do not modify the fixture or install other than genuine Martin parts.
- Never place filters or other materials over the front glass.

## Guarding against injury

- The front glass can be slippery, especially when wet. Ensure that pedestrians are warned and/or kept away from the fixture.
- Block public access during service.

# 3. General operation

## General guidelines

---

To avoid voltage drops which may result if many lamps strike at the same time, there is a short delay before the lamp strikes after power-on.

For optimum lamp life and performance, allow the lamp to warm up fully for five minutes before turning it off. Turn off lamp power whenever illumination is not required for periods of one hour or more. Fixture power may remain on when not in use.

When the temperature is expected to fall below freezing, leave the fixture powered on when not in use to keep the electronics warm. The lamp, however, may be switched off.

## Understanding shows and scenes

---

If you are not familiar with programmable lighting, it will help you follow the rest of this manual if you understand the concept of scenes and shows.

A scene is an effect that consists of a certain color displayed at a certain intensity. A show, or program, is a sequence of scenes which can be repeated again and again, if desired.

Scenes consist of a *Fade* period during which lighting fixtures change to the desired effect, and a *Wait* period, during which fixtures continue to display the desired effect.

The example on the right is a lighting show consisting of 3 scenes. These 3 scenes could for example be:

1. 30 seconds fade from blackout to 40 seconds of 100% intensity red light.
2. 30 seconds fade to 30 seconds of 50% intensity blue light.
3. 20 seconds fade to 120 seconds of 80% intensity white light.

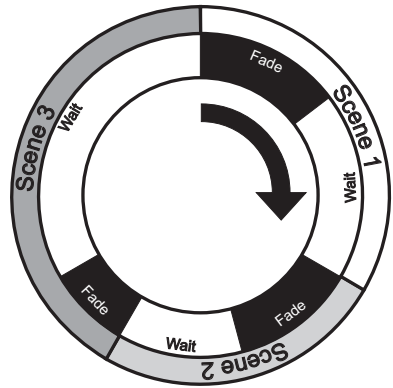

## Powering on for the first time

---

When the Inground 200 CMY is connected to power for the first time, it will start running a factory-set light show to test the fixture. It will continue to run this test show until a new show is programmed into it, or until it receives DMX commands.

### Initial test show

The Inground 200 CMY is pre-programmed with 5 scenes to verify that the CMY flags and the dimmer are working correctly.

1. White 100% intensity.
2. Cyan 100% intensity.
3. Magenta 100% intensity.
4. Yellow 100% intensity.
5. White 0% intensity (no light).

## Control and programming options

---

The Inground 200 CMY can receive control and programming data via two inputs:

- via the RJ45 service connector on the lamp module under the front glass and lens
- via the DMX control data link.

The RJ45 service connector has priority. This means that while data is being received via the service connector, the fixture ignores any data received via the data link.

## Control and programming methods

The Inground 200 CMY can be programmed and controlled using one of the methods listed below.

### Stand-Alone programming

Using a PC with MUM software or a Martin MP-2 Uploader you can program and store stand-alone light shows in individual fixtures:

1. Any fixture can be programmed to run its own independent stand-alone show.
2. One fixture can be programmed to run a show and also send scene-change signals to any number of other fixtures via the data link, so that all fixtures run a synchronized stand-alone show. Fixtures in synchronized stand-alone shows can show identical or different scenes, but all fixtures will change scene at the same time.

Stand-Alone programming is described in “*Section 2. Stand-Alone operation*” on page 19.

### DMX control

Using a DMX device to control fixtures via a data link, fixtures can be controlled independently or in groups.

DMX control is described in “*Section 3. DMX control*” on page 37.

## Initial configuration for use

---

Before the Inground 200 CMY can be programmed or controlled, certain fixture settings need to be configured. This section describes how to

configure these using either the Martin MUM™ (Multi-Utility Manager) application or an MP-2 Uploader if available.

### **Martin MUM application**

MUM is a Windows PC software application that must be used in combination with a DABS1™ hardware interface.

We recommend MUM because it provides an intuitive, easy-to-use, graphic user interface.

MUM only allows you to connect to, and set up, one fixture at a time.

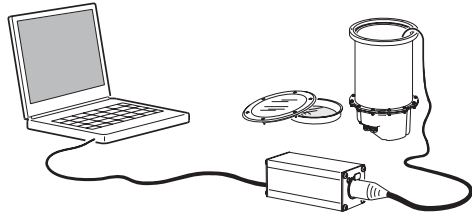

For details of how to use MUM, see “*Defining fixture settings using MUM*” on page 12.

### **Martin MP-2 Uploader**

If you have an MP-2, it can be loaded with the Inground 200 CMY’s control software and connected to either a data link or a single fixture, as illustrated below. The MP-2 user manual contains full details of uploading options and methods.

When working with multiple fixtures, an MP-2 allows you to apply settings globally to multiple fixtures on a data link.

The MP-2 provides a text-based interface and the fixtures do not provide feedback to the uploader.

Therefore, the current settings of the fixture can only be “read” by observing the behavior of the fixture.

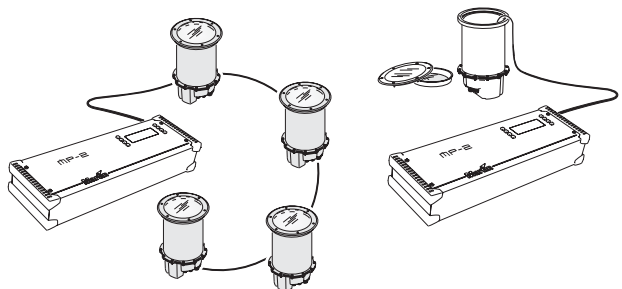

For details of how to use the MP-2, see “*Defining fixture settings using an MP-2*” on page 15.

# Defining fixture settings using MUM

---

Using MUM, you can connect to and set up one fixture at a time. Refer to the *MUM User Manual* (available on the Martin website at <http://www.martin.com>) for instructions on installing and starting the MUM application.

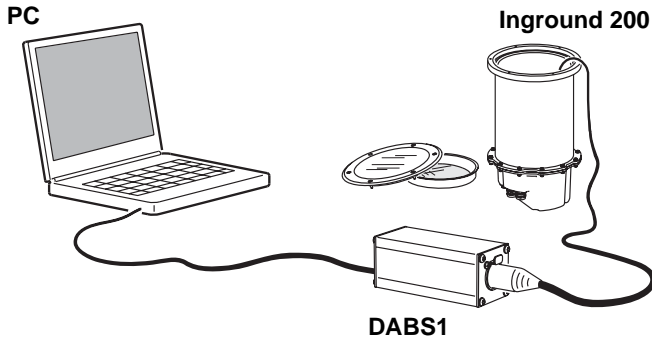

MUM must be used with a DABS1 interface device. A complete package containing MUM, the DABS1, documentation and all cables is available from Martin dealers (P/N 90758090). The package includes an XLR-to-RJ45 cable to connect the DABS1 to an Inground 200 CMY. This cable is also available separately (P/N 11840087).

To get started:

1. Connect a PC to a DABS1 and connect the DABS1 to an Inground 200 CMY.
2. Power on the Inground 200 CMY and start the MUM application. MUM will automatically detect an Inground 200 CMY if it is powered on and connected. It will also retrieve the current settings from the fixture and display them.

## Setting the onboard clock

The Inground 200 CMY has a battery-operated 24-hour clock that can start and stop stand-alone operation.

To set the clock:

1. in the main MUM window, click on the **Fixture info** button:

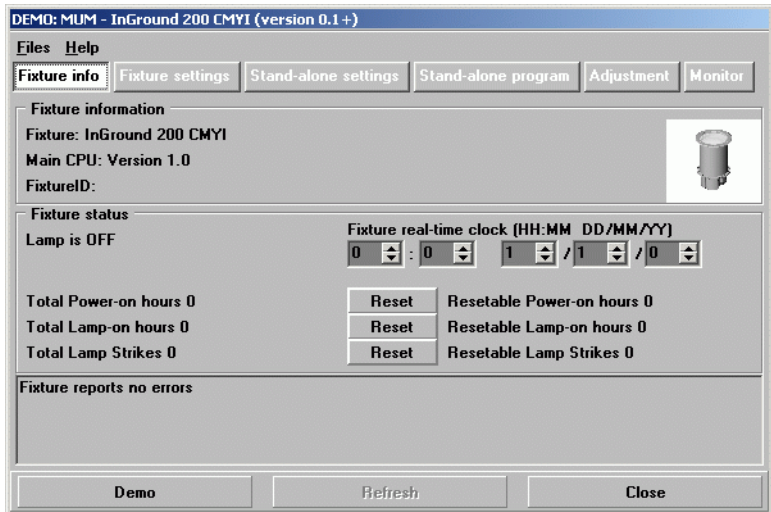

2. Using the two **Fixture time** spin buttons, set the fixture to the current time and date (expressed in the 24-hour clock in hours and minutes, then in DD/MM/YY format). The time will be updated in the fixture in real-time.

## Fixture settings

To set the additional fixture settings, click on the **Fixture settings** button:

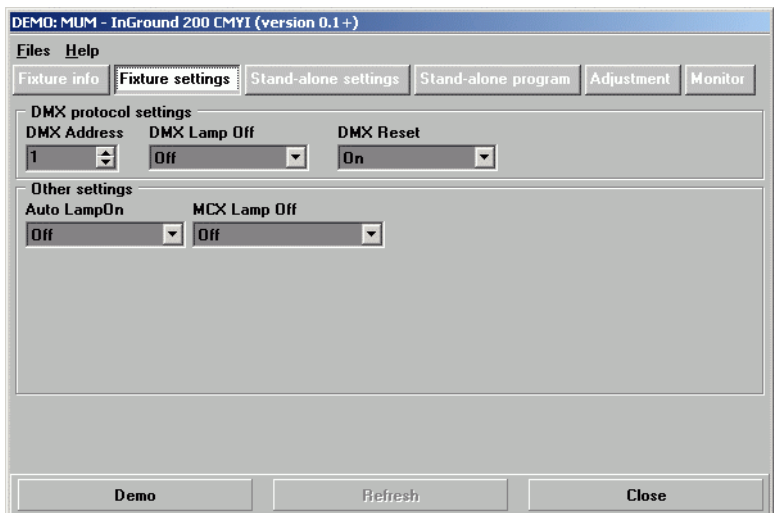

## DMX address

If you are not familiar with the DMX lighting control protocol, it will help if you read through “*DMX Controller operation*” on page 37.

The DMX address (also known as the control address, or start channel) is the first channel used to receive instructions from the DMX controller. Each fixture needs its own DMX address set, and uses this address (and control channels immediately above this address) to receive instructions.

The Inground 200 CMY reads the data on its start channel and the next five channels. If the control address is set to 100, the fixture uses channels 100, 101, 102, 103, 104 and 105. Channel 106 can be used as the DMX address for the next fixture.

If two or more fixtures are set up with the same address, they will receive the same instructions and should behave identically. Setting up identical fixtures with the same address is a good tool for troubleshooting unexpected behavior and an easy way to achieve synchronized action.

To set the DMX address use the **DMX Address** spin button. The fixture address is updated in real time.

## DMX Lamp Off

When the **DMX Lamp Off** personality is on (the default setting), lamp power can be turned off from the controller by setting channel 1 to a decimal value from 248 to 255.

## DMX Reset

When the **DMX Reset** personality is on (the default setting), the fixture can be reset from the controller by setting channel 1 to a decimal value from 208 to 217.

## Auto Lamp On

When the **Auto Lamp On** personality is on, the fixture turns on the lamp within 90 seconds of power on. When set to off (the default setting), a lamp-on command is required to turn on the lamp.

## MC-X Lamp Off

By choosing the option **MCX Preset 7 key** from the **MCX Lamp Off** field, you enable button 7 on an MC-X controller to be used to control the lamp off function.

# Defining fixture settings using an MP-2

---

MP-2 Uploader users can apply settings globally to multiple fixtures on a data link by loading the MP-2 with the Inground 200 CMY's control software and connecting it to a fixture or to the data link. The MP-2 Uploader user manual contains instructions for this procedure.

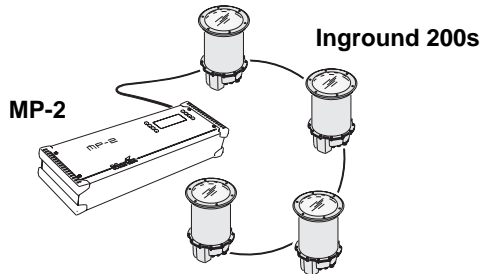

The MP-2 has a text-based interface and does not receive feedback from fixtures. Therefore, the current settings of the fixture can only be “read” by observing the behavior of the fixture.

## Single-fixture and all-fixture modes

The MP-2 provides two ways to access fixtures: single-fixture mode and all-fixtures mode. In single-fixture mode, the uploader communicates only with the fixture at a designated address. In all-fixtures mode, the uploader communicates with all fixtures of the same type to which it is connected.

Fixture-specific settings such as the control address should be made in single-fixture mode. If no other fixtures are connected, however, then all-fixtures mode may be used. Global settings are easiest to apply in all-fixtures mode.

## DMX address

The DMX address, also known as the control address, or start channel, is the first channel used to receive instructions from an uploader. Each fixture needs its own control address set, and uses this address and subsequent control channels to receive instructions from an uploader or controller.

The Inground 200 CMY uses seven control channels. It reads the data on the start channel and the next six channels. If the control address is set to 100, the fixture uses channels 100, 101, 102, 103, 104, 105, and 106. Channel 107 would be the control address for the next fixture.

If two or more fixtures are set up with the same address, they will receive the same instructions and should behave identically. Setting up identical

fixtures with the same address is a good tool for troubleshooting unexpected behavior and an easy way to achieve synchronized action.

**Important!** *When setting the address, either use single-fixture mode or isolate all other fixtures from the uploader.*

To set the control address:

1. Prepare an MP-2 or similar upload device as described in the uploader user manual. If you know the address to which the fixture is currently set, (i.e. the address to change *from*), connect the uploader to the data link and use single-fixture mode. Otherwise, use all-fixtures mode and isolate all other fixtures from the uploader. Apply power to the fixture.
2. If using single-fixture mode, scroll to the fixture's current address and press OK (in all-fixtures mode this step is not necessary).
3. Select **Fixture address** from the **Fixture Menu**.
4. Scroll to the desired control address and press OK.
5. Press OK again to confirm and save the setting.

## Personality settings

The following settings are available in the uploader's **Personality** menu to modify fixture behavior.

**DMX lamp off:** When the DMX lamp off personality is on (the default setting), lamp power can be turned off from the controller by setting channel 1 to a decimal value from 248 to 255.

**DMX reset:** When the DMX Reset personality is on (the default setting), the fixture can be reset from the controller by setting channel 1 to a decimal value from 208 to 217.

**Auto lamp on:** When the Auto lamp on personality is on (the default setting), the fixture turns on the lamp within 90 seconds of power on. When set to off, a lamp-on command from a DMX controller or an onboard timer is required to turn on the lamp.

**MC-X lamp off:** When the MC-X Lamp-off personality is on (the default setting), the lamp can be doused with a command from an MC-X controller.

To set a personality setting:

1. Prepare and connect an MP2 or similar upload device as described in the device's user manual. Apply power to the fixture.
2. Select single fixture mode to change a setting on a single fixture, or all-fixtures mode to make global changes.
3. If using single-fixture mode, enter the fixture's address.
4. Select **Personality** from the fixture menu.
5. Select the desired personality and setting. (See "MP-2 control menu structure" on page 61.) Press OK.

## Clock

The Inground 200 CMY has a battery operated 24-hour clock that can start and stop stand-alone operation.

To set the clock:

1. Prepare and connect an upload device as described in the MP2 Uploader manual. Apply power to the fixture.
2. Select all-fixtures mode.
3. Select **Adjust -> Real time clock** from the fixture menu.
4. Select **Hour** and scroll to the current hour.
5. Press OK.
6. Select **Minute** and scroll to the current minute.
7. Press OK.
8. Press **Back** to return to the main menu.



# SECTION 2. STAND-ALONE OPERATION

## 4. Stand-alone programming overview

Stand-alone is a mode where the fixture executes color changes at set intervals and speeds, at pre-defined periods during the day. The term *stand-alone* is used to mean that the Inground 200 CMY is not connected to a control device, but is pre-programmed with a series of up to 20 scenes that play continuously in a loop.

'Stand-alone operation' involves:

- a single fixture running independently, or
- multiple fixtures running synchronously.

For multiple fixtures to run synchronously, one 'master' fixture must send trigger signals to the other 'slave' fixtures via a DMX control data link. The slave fixtures must all be programmed individually with shows, but each scene in their shows is started by a trigger signal from the master fixture.

An Inground 200 CMY running a pre-programmed show can perform synchronized scene changes with up to 31 other Martin Architectural fixtures of the following types:

- Inground 200™ 6 Color
- Inground 200™ CMY
- Exterior 200™
- Exterior 600™
- Exterior 1200™ Wash
- Exterior 1200™ Image Projector
- Cyclo™ DMX models including Cyclo IP65 DMX
- FiberSource™ CMY150
- Imager™ series
- Alien 02™ series
- MiniMAC™ Maestro
- Exterior 200™ LED

More fixtures can be added to an installation by using one or more Martin RS-485 Opto-Splitters. This small DMX amplifier will allow up to 4 additional branches to be added to a data link, with 32 fixtures possible on each

## About scene timing

---

Each scene in a show has two parts:

1. a dynamic part - the *fade* - during which effects move to the scene's programmed positions
2. a static part - the *wait* - where effects do not change.

The duration of the fade and wait is programmed individually for each scene. The fade and wait times can be between 0 seconds - 18 hours. The total time it takes a scene to execute is the fade time plus the wait time.

When operating multiple fixtures synchronously, the wait time is determined by the master fixture. Slave fixtures fade at their own rate and then remain in the “wait” state until they receive a “start scene” or “start show” trigger from the master.

When programming in synchronous triggering situations, you can make life much easier if you make sure that:

1. Every fixture has the same number of scenes.
2. Respective scene times are a few seconds longer on the master fixture than on the slave fixtures.

The rules used in the master/slave algorithm are detailed in “*Synchronous triggering during Stand-Alone operation*” on page 35.

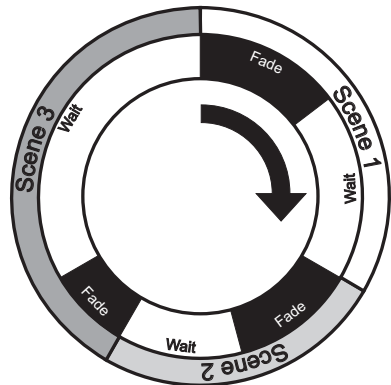

## Synchronizing scene changes for multiple fixtures

---

If you are running multiple Inground 200 CMYs on a data link, it is possible to synchronize scene changes.

**Note:** Each individual fixture must be programmed with a show. The only commands that are transmitted by the master fixture are scene change commands. No data about the look of the scene is transmitted between fixtures.

# Programming methods

---

The Inground 200 CMY provides two stand-alone programming methods; using:

1. the Martin MUM application on a Windows PC (recommended because it provides an intuitive, easy-to-use, graphic user interface), or
2. an MP-2 Upload device, if available. See “*Programming using an MP-2 Uploader*” on page 27.

If you are programming a group of fixtures to perform the same scenes with synchronized triggering then we recommend that you either:

1. Use MUM to program fixture settings and a show on a single fixture, download and save the fixture memory to a file on your PC using MUM's **Files** menu, and then upload this file to each subsequent fixture that you connect to, or
2. Use an MP-2 Uploader, if available, to program the same show on all the fixtures on the network simultaneously (you can then assign their individual DMX address afterwards).

## 5. Programming from a PC using MUM

The programming of scenes, and setting up of master/slave relationships, can be performed from a personal computer running the MUM application. The PC must be connected to a fixture via a DABS1 adaptor. The PC is used to program the stand-alone settings for that fixture, and then removed. When this fixture is subsequently switched on, it can automatically run the scenes in its show in a loop for two periods in each 24 hour period.

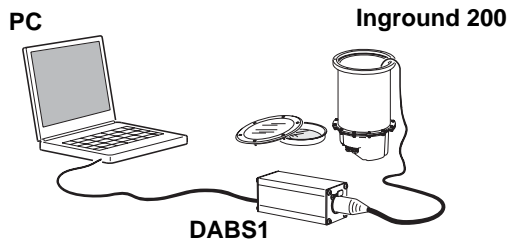

If you are not familiar with the use of MUM, it is recommended that you familiarize yourself with it by reading the *MUM user manual*.

# Getting started with MUM

---

To get started:

1. Connect a DABS1 adaptor to your PC and an Inground 200 CMY using the cables supplied in the MUM/DABS1 package. Replacement cables are available from your Martin dealer.
2. Power on the Inground 200 CMY and start the MUM application. The application will automatically detect an Inground 200 CMY if it is powered-on and connected to your computer via a DABS1 adaptor. It will also retrieve the current settings on the fixture and display them.

## Stand-Alone Settings

---

The fixture needs to be configured to know if and when to activate a stand-alone show:

Click **Stand-alone settings** to display the following window.

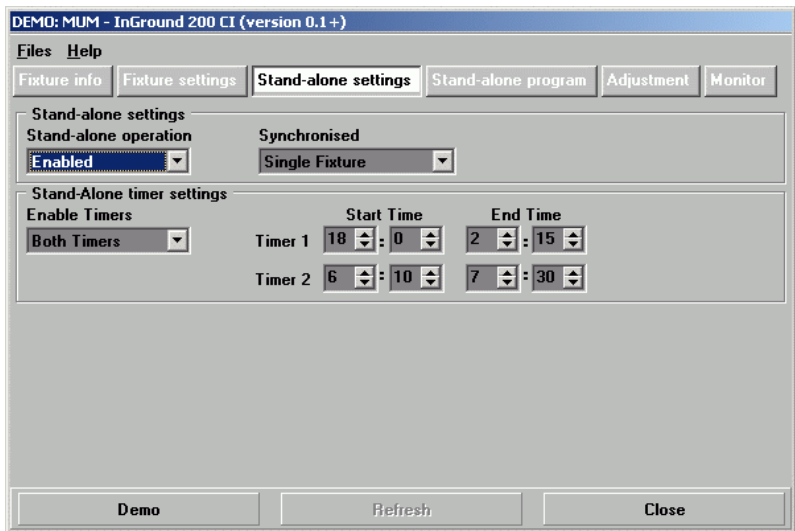

The following options are available:

**Stand-alone operation**

Enables or disables stand-alone operation.

- Synchronized** Specifies if the fixture operates as a:
- **Single Fixture** (runs independently of any other fixtures)
  - **Master** (triggers other fixtures) or
  - **Synchronized** (slave fixture, receives trigger signals from a master fixture).
- Note:** No more than one fixture may operate as master. Any fixture on the DMX control link, however, regardless of its position, may be the master. All other fixtures must be set as slave fixtures by setting them to **Synchronized**.
- Stand-alone timer settings** Enables timer 1 only, timer 2 only, or both timers (see “*Automatically triggering stand-alone operation*” on page 31)

## Synchronizing shows on multiple fixtures

To synchronize scene changes, you need to set up one ‘master’ fixture to trigger show starts and scene changes in the other ‘slave’ fixtures. Each slave fixture needs to have its own show programmed. The master fixture triggers the slave fixtures’ show starts and scene changes in a cycle in time with its own show.

Each slave fixture will run its programmed show in a loop, changing scene when it receives a trigger from the master fixture that tells it to go to a scene number. When the master fixture finishes its own show, it sends a ‘go to scene 1’ trigger that causes the slave fixtures to start their shows again from scene 1.

**Note:** Each individual fixture must be programmed with its own show – the master fixture only sends signals specifying the current scene number. No data about the appearance of the scene is transmitted between fixtures.

## Setting stand-alone operation with the onboard clock

Stand-alone operation can be set for one or two periods during a 24 hour period, using the built-in timers.

**Note:** If you are using a master and slave configuration, all fixture timers must be set to switch fixtures on and off at the same times.

1. First set the correct time. See “*Setting the onboard clock*” on page 12.

2. Set **Enable Timers** to one or two timers depending on whether you want one or two periods of operation in each 24 hour period.

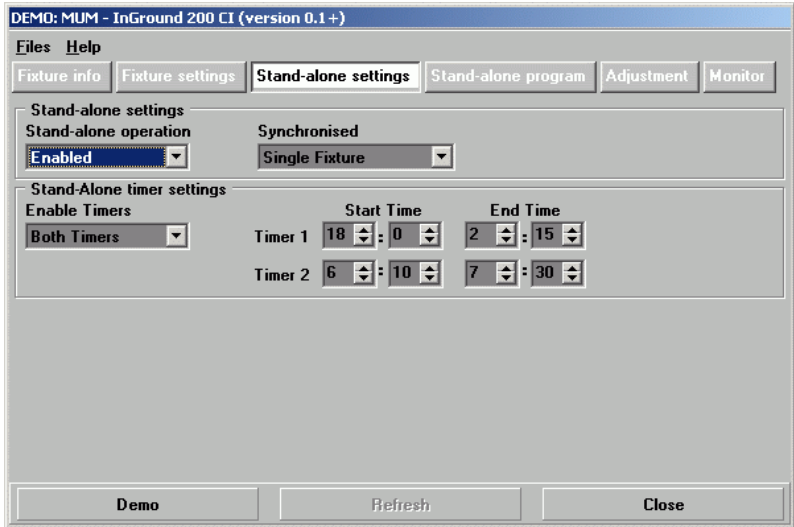

3. Then set the desired **Start Time** and **End Time** for each timer you have enabled.
4. Select **Enabled** in the **Stand-alone operation** drop-down menu.
5. Remember to select **Single Fixture, Master** or **Synchronized** in the **Synchronized** drop-down menu

## Programming effects in scenes

---

The programming of light effects is performed using the **Stand-alone program** controls.

# Inground 200 CMY stand-alone options

Click on the **Stand-alone program** button to open the programming window:

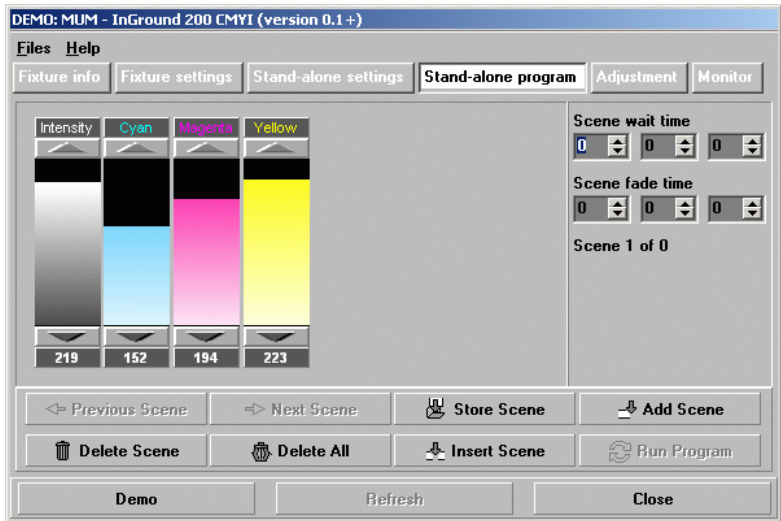

The following options are available:

- |                        |  |
|------------------------|--|
| <b>Intensity</b>       | Sets dimmer level.   |
| <b>Cyan</b>            | Selects color by CMY levels.   |
| <b>Magenta</b>         |  |
| <b>Yellow</b>          |  |
| <b>Scene fade time</b> | The fade time, which can be between 0 seconds to 18 hours, is the time it takes to change from one color to another.   |
| <b>Scene wait time</b> | This is the duration a color is applied. A wait time can be between 0 seconds and 18 hours. If wait times are set to 0 seconds, colors will change continuously. |

## Master/slave fade and wait times

When operating multiple fixtures in synchronized-triggering mode, slave fixtures fade and wait according to the programmed fade and wait times for the scene they are running. Once a slave fixture's programmed wait time is over, the slave fixture remains in wait mode until it receives a trigger from the master fixture telling it to go to another scene. If the slave fixture's wait time is not over, it will not accept 'go to scene number XX' commands from the master fixture.

Therefore, when programming a master fixture, keep in mind that its total scene times should be equal to or longer than the fade times of the other fixtures. You will get unpredictable results if, for example, a scene is

programmed in the master to last 10 seconds and in other fixtures to fade for 15 seconds (if necessary, see “*Synchronous triggering during Stand-Alone operation*” on page 35 for a more detailed explanation).

## Scene management

Once you have specified a mix of effects, you can store the scene using the buttons available in the main MUM window:

<b>Store scene</b>	Save settings in the current scene.
<b>Add scene</b>	Save settings in a new scene at the end of the sequence.
<b>Insert scene</b>	Save settings in a new scene before the current scene, which moves up a number. <i>Tip: Think of the Add and Insert commands as Save commands, to be used as the last step after programming all effects.</i>
<b>Delete scene</b>	Remove the current scene from memory. Scenes above the deleted scene move down a number.
<b>Next scene</b>	Step to the next scene.
<b>Previous scene</b>	Step to the previous scene.
<b>Delete all</b>	Remove all scenes from the fixture memory.
<b>Run program</b>	Run the scenes in the current programmed show.

When the show is run, scenes execute in a continuous, ascending loop.

**Note:** If a slave fixture has:

- Fewer scenes than the master fixture, it will run these in a cycle continuously until the master fixture signals that the show should start from the beginning again.
- More scenes than the master fixture, then the additional scenes will never run, because the show will reset to the first scene when the master starts its show from the beginning.

## Programming the same stand-alone show on multiple fixtures

---

Although you can only connect to and program a single fixture at a time using the MUM application, you can use it to “copy” settings and shows from one fixture to another. To do this, program a single fixture, then use the commands in MUM’s **Files** menu to download and save the fixture settings to a file on your PC. You can then upload the fixture settings and stand-alone show to each subsequent fixture that you connect to. This short-cut is useful if you have a group of fixtures that will run the same stand-alone

show. If you copy all settings using this method, remember to set one fixture to master and the rest to synchronized.

## 6. Programming using an MP-2 Uploader

The programming of scenes, and setting up of master/slave relationships, can be performed using a Martin MP-2 Uploader, if available. The uploader is connected to the fixture, used to program the stand-alone settings for that fixture (or all the fixtures connected to that fixture by data link), and then removed. When you power fixtures on, they can then automatically run their programmed scenes at the times you specify.

To summarize, you can use the MP-2 Uploader to program:

- Individual fixtures, one at a time.
- The same show in multiple fixtures that are linked with data cables.
- Individual shows in multiple fixtures that are linked with data cables.

If you are not familiar with the use of the MP-2, it is recommended that you familiarize yourself with it using the MP-2 Uploader manual.

You can find an overview of the functions and commands available in the MP-2 in *“MP-2 control menu structure”* on page 61.

### Getting started

---

An uploader can be connected either:

- via the DMX link
- via the RJ45 service connector socket under the front glass and lens (see *“Removing the front glass and lens”* on page 44). To connect an MP-2 to

the service connector you will need a 3-pin male XLR-to-RJ45 cable (available from your Martin dealer: P/N 11840087).

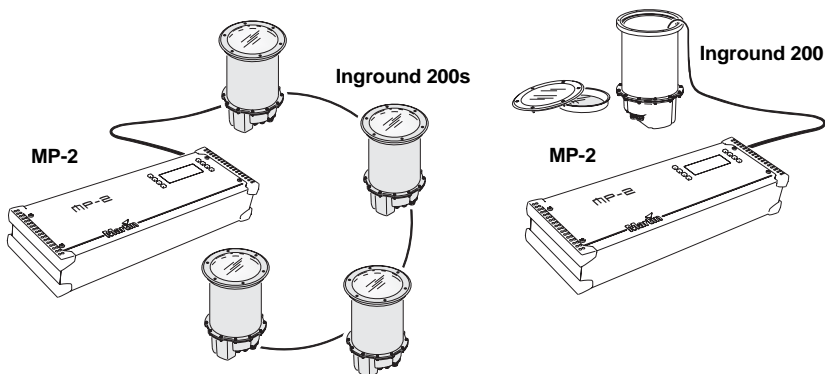

1. Plug either the fixture's or the data link's, data-input cable into the 3-pin female XLR "DMX/RS-485 OUT" socket on the MP-2.
2. Apply power to the fixture and the MP-2.
3. Select **Read Memory Card** from the MP-2 menu.
4. Select **NEG VX.X.X**. (Note that **X.X.X** is the number that corresponds to the firmware version that is loaded in the fixture.)
5. Select **Fixture menu**. Then use the keys on the uploader to navigate and select the desired menu item. For further guidance see the following sections.

## Selecting fixtures to program

---

Before you select a fixture to program, its control address must have been set. If you have not yet done so, follow the instructions described in "DMX address" on page 15.

You have the option of programming all the Inground 200 CMYs on a data link, or an individual Inground 200 CMY. Fixture-specific settings such as the control address should be made in single-fixture mode. If no other fixtures are connected, however, then all-fixtures mode may be used. Global settings are easiest in all-fixtures mode. For example, it can be a good idea to program the time into all fixtures simultaneously, while scenes can be programmed into fixtures individually.

**Note:** It is important that all the fixtures have the same software version, or the results will be unpredictable. For more information see "Firmware updates" on page 55.

### Selecting a single fixture

To program a single fixture:

1. Select **Single address** from the Fixture menu.
2. Select a start address that corresponds to the fixture that you want to program using the arrows.

*As you scroll through the start addresses, watch for a reaction from the fixture you want to program. Make sure you select the start address of this fixture, i.e. the lowest DMX channel the fixture uses, and not one of the fixture's other DMX channels.*

3. Select **OK**.

## Selecting all fixtures on a data link

To program all fixtures on the data link simultaneously, select **All addresses** from the Fixture menu.

## Enabling or disabling stand-alone mode

---

To:

- Disable stand-alone mode, select **Stand alone**, then **Enable SA**, and then **Off**.
- Enable stand-alone mode, select **Stand alone**, then **Enable SA**, and then **On**.

When stand-alone mode is enabled, fixtures enter stand-alone mode each time power is applied. Stand-alone mode can be disabled temporarily by:

- Turning the fixture off.
- Connecting a controller and sending control signals.

## Synchronizing scene changes for multiple fixtures

---

If you are running more than one Inground 200 CMYs on a data link, it is possible to synchronize scene changes. Read this section if this applies in your case.

To synchronize scene changes, you need to set up one 'master' fixture to trigger show starts and scene changes in the other 'slave' fixtures. Each slave fixture needs to have its own show programmed. The master fixture triggers the slave fixtures' show starts and scene changes in a cycle in time with its own show.

Each slave fixture will run its programmed show in a loop, changing scene when it receives a trigger from the master fixture that tells it to go to a scene

number. When the master fixture finishes its own show, it sends a 'go to scene 1' trigger that causes the slave fixtures to start their shows again from scene 1.

**Note:** Each individual fixture must be programmed with its own show – the master fixture only sends signals specifying the current scene number. No data about the appearance of the scene is transmitted between fixtures.

## Setting synchronized triggering options

1. Scroll to **Stand Alone** in the top level of the menus on the control panel and press [enter].
2. Scroll to **SA Execution** and press [enter].
3. Select:

<b>Single fixture</b>	If the fixture will operate in isolation (with no synchronous triggering). This is the factory default setting.
<b>Master</b>	If the fixture will send scene triggering signals to the other fixtures on the data link.
<b>Synchronized</b>	If the fixture should operate in slave mode and "listen" for scene trigger signals on the data link.

4. Press [enter].

## Defining a master fixture

*No more than one fixture may be the master.* Any fixture on the link, however, regardless of its position, may be the master.

1. From the **Stand alone** menu, select **SA Execution**.
2. Select **Master**. This designates the fixture as the master fixture and causes it to transmit synchronization signals to the slave fixtures when it runs its show.

## Defining slave fixtures

All other fixtures must be set as slave fixtures:

1. From the **Stand alone** menu, select **SA Execution**.
2. Select **Synchronized**. This designates the fixture as a slave fixture which will respond to synchronization signals received from the master fixture.

# Automatically triggering stand-alone operation

---

Stand-alone operation can be set for one or two periods during a 24 hour period using the built-in clock.

## Setting a timer trigger

First set the correct time. See “Clock” on page 17.

You can set timer operation for a single period, or for two periods, for example, one period in the morning, and one period in the evening. To set the timer for a single period:

1. Select **Stand alone** from the Fixture menu.
2. Select **Timer**, then **Timer1**.
3. Select **Start**, then **Hour**. Use the arrow keys to specify the start hour. Select **OK**.
4. Select **Minute**. Use the arrow keys to specify the start minute. Select **OK**.
5. Select **Back**.
6. Select **Stop**, then **Hour**. Use the arrow keys to specify the stop hour. Select **OK**.
7. Select **Minute**. Use the arrow keys to specify the stop minute. Select **OK**.
8. Select **Back**.
9. Select **Enable** and select the timer you want to activate (in this case, Timer 1).

## Programming effects in scenes

---

The programming of effects is performed using the stand alone Program menu options, such as:

**Intensity** Dimmer level.

**Cyan** Color

**Magenta**

**Yellow**

**Fade time** The fade time is the time it takes to change from one color to another. A fade time can be between 0 seconds and 18 hours.

**Wait time** This is the duration a color is applied. A wait time can be between 0 seconds and 18 hours.

## Master/slave fade and wait times

When operating multiple fixtures in synchronized-triggering mode, slave fixtures fade and wait according to the programmed fade and wait times for the scene they are running. Once a slave fixture's programmed wait time is over, the slave fixture remains in wait mode until it receives a trigger from the master fixture telling it to go to another scene. If the slave fixture's wait time is not over, it will not accept 'go to scene number XX' commands from the master fixture.

Therefore, when programming a master fixture, keep in mind that its total scene times should be equal to or longer than the fade times of the other fixtures. You will get unpredictable results if, for example, a scene is programmed in the master to last 10 seconds and in other fixtures to fade for 15 seconds (if necessary, see "*Synchronous triggering during Stand-Alone operation*" on page 35 for a more detailed explanation).

## Scene management

Once you have specified a mix of effects, you can store the scene using the options available under the Program menu:

<b>Store scene</b>	Save settings in the current scene.
<b>Add scene</b>	Save settings in a new scene at the end of the sequence.
<b>Insert scene</b>	Save settings in a new scene before the current scene, which moves up a number. <i>Tip: Think of the Add and Insert commands as Save commands, to be used as the last step after programming all effects.</i>
<b>Delete scene</b>	Remove the current scene from memory. Scenes above the deleted scene move down a number.
<b>Next scene</b>	Step to the next scene.
<b>Previous scene</b>	Step to the previous scene.
<b>Clear scenes</b>	Remove all scenes from the fixture memory.
<b>Run program</b>	Run the scenes in the current programmed show.

The only indication of what the current scene is comes from the behavior of the fixture.

When the programmed show is run, scenes execute in a continuous, ascending loop.

If a slave fixture has:

- Fewer scenes than the master fixture, it will run these in a cycle continuously, until the master fixture signals that the show should start from the beginning again.
- More scenes than the master fixture, then the additional scenes will never run, because the show will reset to the first scene when the master starts its show from the beginning.

## Disconnecting the MP-2 Uploader

---

When all the settings have been made, disconnect the data input cable from the MP-2.

# 7. Stand-Alone show playback

## Starting show playback automatically at fixture power-on

---

Execution of programmed scenes in a loop will start automatically when the fixture is powered-on if stand-alone operation is enabled and the automatic lamp-on function is enabled.

To check or define this function:

- If you are using MUM on a PC, see “*Stand-Alone Settings*” on page 22 and “*Auto Lamp On*” on page 14.
- If you are using an MP-2 uploader, see “*Enabling or disabling stand-alone mode*” on page 29 and “*Auto Lamp On*” under “*Personality settings*” on page 16.

## Scene execution using the optional MC-X

---

The MC-X is an optional remote control module that is available from Martin. Once the remote controller is connected, 7 scenes can be conveniently called up on the MC-X’s buttons.

## Enabling MC-X control

### Using an MP-2

For each fixture:

1. Disable stand-alone operation on each fixture: select **Stand alone / Enable SA / OFF** and press [enter]. Press [menu] to exit the **Stand alone** menu.
2. Using the **Personality / MC-X lamp off** menu it is possible to set button 7 on the MC-X to control the lamp off function. See “*MP-2 control menu structure*” on page 61.

### Using MUM

For each fixture:

1. Disable stand-alone operation. See “*Stand-Alone Settings*” on page 22, under the chapter “*Programming from a PC using MUM*”.
2. Enable lamp-on from the MC-X. See “*MC-X Lamp Off*” on page 14 in the section “*Defining fixture settings using MUM*”.

## Connecting and using the MC-X Controller

1. Connect the MC-X controller to the Inground 200 CMY’s data network via an XLR-to-RJ-45 adaptor. If multiple Inground 200 CMYs are connected, plug the controller into the first fixture in the link.
2. To trigger scenes 00-06, press the numbered preset buttons 1 - 7 on the MC-X.
3. To have each fixture run its own routine, press [Auto].

## DMX controller override during stand-alone show playback

---

If an Inground 200 CMY is connected to a DMX controller and receives DMX signals during show playback, the Stand-Alone show will stop running and the fixture will respond to the DMX controller. DMX signals always have priority over the running of a Stand-Alone show.

# 8. Synchronous triggering during Stand-Alone operation

**Note:** *This chapter details the rules that are used in Stand-Alone synchronous triggering. It is not necessary to read this chapter unless you require help with problem diagnosis or unless you otherwise need a detailed understanding of the algorithm used for synchronous triggering.*

The rules are as follows:

1. Every fixture can have up to 20 on-board scenes with individual fade and wait times.
2. Scenes are numbered from 0 to 19.
3. A scene contains a fade-section, followed by a wait-section.
4. When running “synchronous triggering” one master Inground 200 CMY issues commands to the other slave Inground 200 CMYs to “go to scene xx”, where xx is the scene number that the master will execute next.
5. If a slave has fewer scenes than the master, it will derive which scene to go to by dividing the number of the scene it has been commanded to go to (scene 5, for example) by the total number of scenes that the slave fixture has (4, for example) in whole numbers (no decimal places). In this example 5 divided by 4 results in 1, with 1 remainder. This remainder will be the number of the scene that the slave fixture starts - scene 1.  
Generally though, when a slave fixture reaches its own last scene before the master fixture, a “go to scene xx” message will result in the first scene being played.
6. If a slave has more scenes than the master calls, the last scenes in the slave will never be executed, as is the case with scene S4 in the following example.

F=fade, W=wait	Timeline =>				
Programmed in Master	M0	M1	M2	M3	
	F   W	F   W	F   W	F   W	
Programmed in Slave	S0	S1	S2	S3	S4
	F   W	F   W	F   W	F   W	F   W
Result	M0	M1	M2	M3	
	F   W	F   W	F   W	F   W	
	S0	S1	S2	S3	
	F   W	F   W	F   W	-- --	F   W

7. A slave fixture will not listen for the next message from the master fixture before it has finished its current scene. This may result in a slave fixture skipping a scene if the slave has a longer scene time than the master. Note that in the following example the scenes in the slave fixture run out of their programmed sequence because scenes 0 and 2 on the slave are longer than the corresponding scenes on the master.

M=master, S=slave

F=fade, W=wait **Time >**

<b>Programmed</b>		M0	M1	M2				
Master		F	W	F	W	F	W	
Slave		S0		S1		S2		
		F	W	F	W	F	W	
<b>Result</b>		M0	M1	M2	M0	M1		
Master		F	W	F	W	F	W	F
Slave		S0		S2		S1		
		F	W	F	W	..	..	F
						W	..	..

# SECTION 3. DMX CONTROL

## 9. DMX Controller operation

DMX512 is a USITT standard protocol used to send instructions from a DMX controller to lighting fixtures on a data link. A total of 512 control channels are available in one DMX universe. The Inground 200 CMY uses six DMX control channels.

This section describes how to operate the fixture with a standard DMX controller. For use with the Martin MC-X controller, please see “*Scene execution using the optional MC-X*” on page 33. See the DMX protocol starting on page 64 for specific control values.

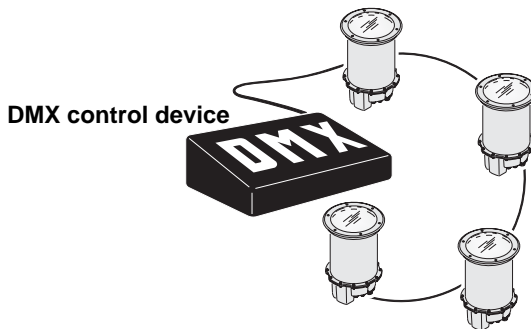

**Important:** *If an Inground 200 CMY receives DMX signals during show playback, the stand-alone show will stop running and the fixture will respond to DMX control. DMX signals always have priority over stand-alone operation.*

### Lamp control

---

The lamp can be turned on and off from the controller using the lamp-on and lamp-off commands on channel 1. If the DMX Lamp-off personality setting is set to **off**, the lamp cannot be turned off using DMX.

To have the lamp strike automatically at power-up, set the Automatic Lamp-on personality to **on** (see page 16). Striking many lamps simultaneously can cause voltage drops, so lamps strike after a short random delay at power-up.

**Note:** After being turned off, the lamp must cool for at least 8 minutes before it can be turned back on.

# Effects

---

The mechanical effects reset to their home positions when the fixture is powered on. Effects can also be reset from the controller on channel 1. If the DMX Reset personality is set to **off**, the fixture cannot be reset using DMX.

## Dimmer

The mechanical dimmer provides smooth, high resolution, full-range dimming on channel 2.

## CMY subtractive color mixing

The CMY color mixing system is based on cyan, magenta, and yellow color filters. A continuous range of colors may be achieved by varying the amount of each filter from 0 to 100% on channels 3, 4, and 5.

**Note:** Mixing 3 colors results in a loss of light - *the light is blacked out when all 3 colors are fully applied*. For maximum brightness, mix only 2 colors at a time.

If you have other types of fixture in the same installation as Inground 200 CMY fixtures, refer to “*Color matching with other fixtures*” on page 39.

## Effect speed

The speed at which effects fade, that is, move from one position to another, can be controlled in two ways known as tracking control and vector control. You may switch between tracking and vector control, but you cannot use both at the same time.

Tracking control is enabled by setting the speed channel 6 to a decimal value from 0 to 2. Fades are then programmed using the controller’s cross-faders. The Inground 200 CMY has a digital filter algorithm that averages several updates to ensure smooth movement.

Vector control provides a way to program fades on controllers without cross-faders and may provide smoother fades than tracking control with some controllers, particularly on very slow fades. A vector speed is programmed by setting the speed channel to a decimal value from 3 (fastest) to 245 (slowest). The speed setting applies to dimmer and color fades. When using vector control, the controller cross-fade time, if available, must be set to 0.

# SECTION 4. OPTICS

## 10. Color matching with other fixtures

If you are running Inground 200 CMY fixtures together with other Martin Architectural fixtures that use different lamps with different color temperatures, etc., colors will not match exactly when the same CMY values are used on the different fixtures.

This applies to an Exterior 600 fitted with an MSD 575 lamp, for example. Generally speaking, the:

- Higher color temperature MSD lamp used in the Exterior 600 will give deeper colors in the cold colors of the spectrum.
- Lower color temperature CDM lamp used in the Inground 200 CMY will give deeper colors in the warm colors of the spectrum.

The following table gives some approximate values for color matching:

<b>Color</b>	<b>Exterior 600 (with MSD 575 lamp)</b>	<b>Inground 200 CMY (with CDM lamp)</b>
White	Magenta 25 Yellow 44	Open
White	Open	Cyan 74
Yellow	Yellow 241 Magenta 16	Full yellow
Magenta	Magenta 100 Yellow 68	Full magenta
Cyan	Full cyan Magenta 25 Yellow 44	Full cyan
Red	Full magenta Full yellow	Magenta 215 Full yellow
Green	Cyan 241 Yellow 241	Full cyan Full yellow
Blue	Full cyan Full magenta	Cyan 255 Magenta 191



# SECTION 5. SERVICE AND TROUBLESHOOTING

## 11. Service procedures

This section describes service procedures that can be performed by the user. Refer all service not described here to a qualified Martin Architectural technician.

**Warning!** *Isolate the fixture from power and allow to cool for at least 15 minutes before removing any cover.*

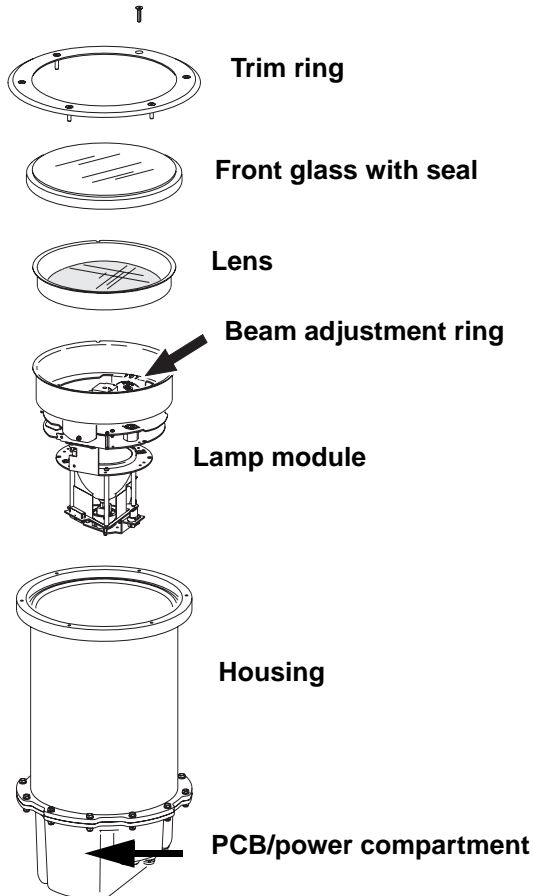

# Clearing excess humidity

---

Each time the Inground 200 CMY is opened, the silica gel anti-humidity sachet fastened to the lamp module must be removed and a new item fastened in its place (see “*Anti-humidity sachet replacement*” on page 45).

Excess humidity inside the fixture can be experienced in the following situations:

- The installation well is waterlogged
- The trim ring and front glass are not sealed correctly on the top of the housing.
- The anti-humidity sachet fastened to the lamp module is saturated or missing.

**Warning!** *If you clear excess humidity as described below:*

- ***The exposed lamp and internals present a risk of electric shock, burns and ultra-violet radiation. A hot discharge lamp is under pressure and there is a risk of lamp explosion. Block public access, wear safety glasses and heat-resistant gloves, handle the lamp module with care, and do not look into the light beam.***
- ***Choose dry weather.***
- ***Ensure that no dust or objects enter the fixture while it is open.***

If there is excess humidity in the Inground 200 CMY, condensation will appear under the front glass. To eliminate excess humidity:

1. Check that the installation has adequate drainage and that the top glass and trim ring are sealed correctly. Rectify any problems.
2. Install a new anti-humidity sachet and reinstall the front glass immediately (new anti-humidity sachets are available from Martin suppliers – see “*Spare parts*” on page 68).

## Cleaning

---

Wash the front glass with a soft brush or sponge and a mild, non-abrasive car washing detergent. Wipe off traces of detergent with a sponge or brush soaked in clean water.

Do not use a hose or high-pressure spray equipment on the fixture. The Inground 200 CMY is water-resistant, but is not designed for submerged operation. Excessive use of water may flood the installation sleeve.

# Seals

---

To maintain the fixture's resistance to dust and moisture, it is important that you replace seals and covers carefully after removal.

The PCB/power compartment cover Allen screws must first be screwed in until they are finger-tight, and then given an extra 3/4 to one full turn. This will ensure that seals are compressed by about one-third. When fitting the front glass trim ring, use a torque driver and cross-tighten the screws gradually to a torque of 6 Nm (4.4 ft.-lbs.).

**Warning!** *Do not use silicone or any other kind of sealant on the front glass seal, front glass, housing or trim ring. Doing so will invalidate the product warranty.*

The silicone seals should maintain their sealing ability for the life of the fixture. However, when servicing the fixture, note the condition of the seals and replace any seal that is cracked, torn, brittle, or inflexible. Replacement seals may be ordered as follows:

- Front glass seal .....P/N 20600441
- PCB/power compartment seal .....P/N 20600450

# 12. Component removal & reinstallation

Tasks such as beam adjustment and lamp replacement require the removal and refitting of certain components. This section contains instructions for these procedures.

Besides safety gloves and safety glasses, you will need a torque driver with a range that includes 6 Nm (4.4 ft.-lbs.) as well as 4mm and 2.5mm Allen bits for these procedures.

**Warning!** *Danger of burns, electric shock and lamp explosion!*

- ***These procedures must be carried out by authorized electrical personnel and in clean, dry conditions only.***
- ***Wear heat-resistant safety gloves and safety glasses throughout these procedures.***
- ***Do not look directly into the lamp.***
- ***Make sure that nothing falls into the fixture while the front glass and lens are removed.***

**Important!** *Any damaged seals or screws must be replaced with new items. Two spare 4mm countersunk Allen screws for the trim ring are supplied with the fixture.*

***The front glass seal, its seating surface in the housing, the front glass and the trim ring must all be perfectly clean and dry during re-installation to maintain a waterproof seal.***

***Do not use silicone or any other kind of sealant on the front glass seal, front glass, housing or trim ring. Doing so will invalidate the product warranty.***

***The anti-humidity sachet inside the fixture must be renewed each time the fixture is opened for service.***

## Removing the front glass and lens

The front glass and lens must be removed for beam adjustment and all other service interventions.

To remove the front glass and lens:

1. Isolate the fixture from AC power and ensure that power cannot be reapplied, even accidentally. Allow the fixture to cool for at least 15 minutes.

2. Brush or if possible vacuum sand, dirt, etc. away and clean the top of the fixture and the surrounding area to ensure that dirt does not fall into the fixture.
3. Remove the six countersunk 4mm Allen screws and lift the trim ring off the fixture

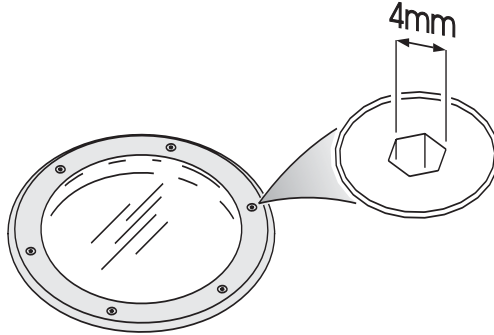

4. Taking care to avoid damaging the seal, lift off the front glass and its seal.
5. The lens is under the front glass, resting on the beam adjustment ring on top of the lamp module. Lift the lens out of the fixture.
6. If a light spill limiter ring (shading plate) and/or a louvered anti-glare plate are installed under the lens, lift them out of the fixture.

## Removing the lamp module

The lamp module must be removed for replacement of the anti-humidity sachet, lamp replacement, and all other service interventions apart from beam adjustment.

To remove the lamp module:

1. Remove the front glass and lens, then any shading plate and/or louvered anti-glare plate fitted, noting the orientation of the louvered anti-glare plate (see *"Removing the front glass and lens"* on page 44).
2. Do not loosen the beam adjustment screws and do not disturb the beam adjustment settings, or the beam will have to be readjusted. Holding the lamp module by the beam adjustment ring, gently lift the whole module upwards until it is clear of the housing.
3. Note the positions of the lamp module wiring connectors, then disconnect them and lift the lamp module away from the fixture.

## Anti-humidity sachet replacement

Each time the Inground 200 is opened for service, or to clear excess humidity at any time, the silica gel anti-humidity sachet fastened to the lamp module inside the fixture must be removed and a new item fastened in its place. The fixture must be closed within 20 minutes of opening the aluminum bag holding the new anti-humidity sachet.

New anti-humidity sachets are available from Martin suppliers (see “*Spare parts*” on page 68 for details).

To renew the anti-humidity sachet:

1. Remove the front glass, lens and lamp module (see “*Removing the front glass and lens*” on page 44 and “*Removing the lamp module*” on page 45).
2. See illustration below. Cut the cable tie holding the silica gel anti-humidity sachet to the side of the lamp module above the cooling fan and remove the sachet.

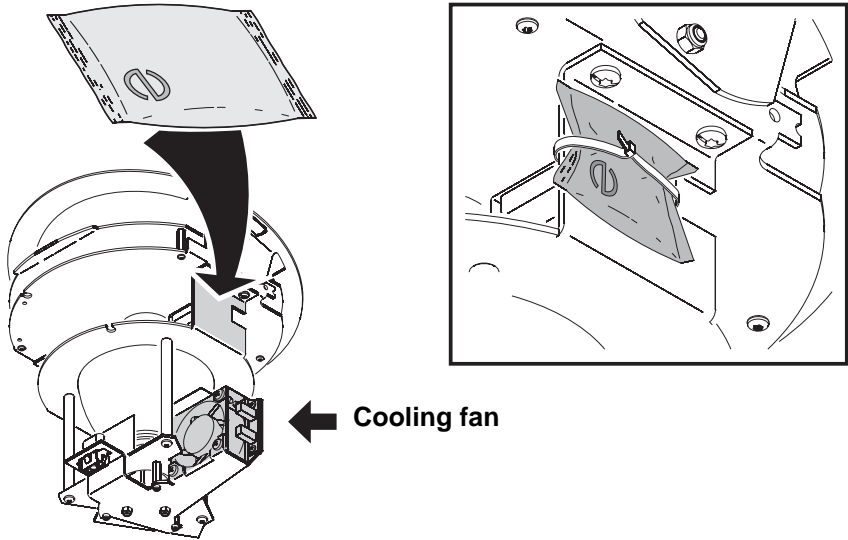

3. Remove a new anti-humidity sachet from its sealed aluminum packet and fasten it with a cable tie in the place of the sachet you have removed. You must now reinstall components and close the fixture within 20 minutes.

## Lamp replacement

The Inground 200 CMY is supplied with a Philips CDM-SA/T 150W/942 discharge lamp.

The Inground 200 CMY may be used with the following lamp types:

<b>Lamp</b>	<b>Efficiency</b>	<b>Color Temp.</b>	<b>Average Life</b>
Philips CDM-SA/T 150W/942	88 Lm/W	4200 K	9 000 hours
Philips CDM-T 150W/830	93 Lm/W	3000 K	12 000 hours
Osram HCI-T 150W/WDL*	97 Lm/W	3000 K	12 000 hours
Osram HCI-T 150W/NDL*	91 Lm/W	4200 K	12 000 hours

**Table 1: Lamp specifications**

*\*WDL = warm daylight, NDL = neutral daylight*

If in any doubt about suitable lamp types, consult your Martin Architectural dealer.

**Important!** *Installing any other lamp type may damage the fixture.*

**Warning!** *Allow the fixture to cool for at least 15 minutes before removing the front glass.*

To replace the lamp:

1. Remove the front glass, lens and lamp module (see “*Removing the front glass and lens*” on page 44 and “*Removing the lamp module*” on page 45).
2. Turn the lamp module upside down and loosen – but do not remove – the three 2.5mm Allen screws on the lamp baseplate pillar bolts.

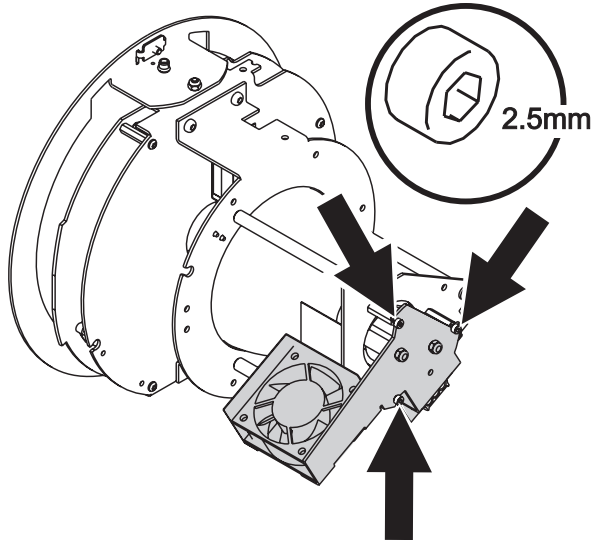

3. Turn the lamp baseplate anti-clockwise a few degrees to release it from the three Allen screws, then gently lift the baseplate assembly off the lamp module.

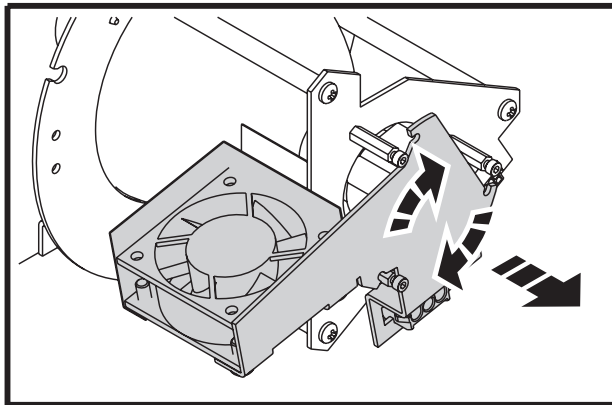

4. Remove the old lamp from the socket. Holding the new lamp by its ceramic base - *do not touch the glass bulb* - insert it firmly and squarely into the lamp socket. Clean the glass bulb with an alcohol wipe or a clean, lint-free cloth wetted with 99.9% isopropyl alcohol.

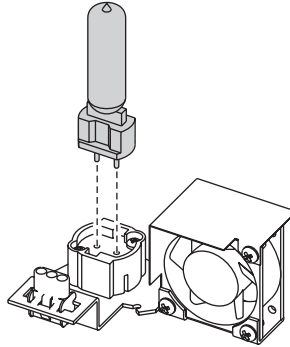

5. Refit the lamp baseplate on the three pillar bolts, twisting clockwise to locate it, and retighten the three Allen screws to secure it.
6. If no further service is required, fasten a new anti-humidity sachet to the lamp module, then reinstall the lamp module, any shading or anti-glare plates originally fitted, the lens and the front glass (see *“Anti-humidity sachet replacement”* on page 45, *“Reinstalling the lamp module”* on page 51 and *“Reinstalling the lens and front glass”* on page 51).

## Accessing the PCB/power module

If you need to perform a boot sector upload, you will need access to the printed circuit board in the PCB/power compartment.

### Removing the PCB/power module

1. Remove the front glass, lens and lamp module (see *“Removing the front glass and lens”* on page 44 and *“Removing the lamp module”* on page 45).
2. The PCB/power compartment is the larger of the two compartments in the bottom of the fixture. Note the positions of the connectors and disconnect the connections to this compartment.

3. See illustration below. Remove the five 5mm Allen screws from the PCB/power compartment cover plate.

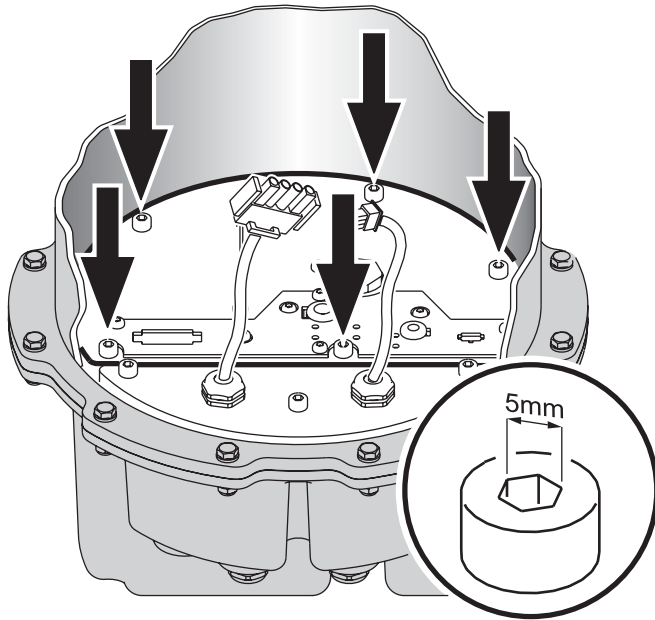

4. Holding the cover plate by its wire service handle, lift it carefully upwards, avoiding damage to the seal. The two PCBs and the power components are mounted on the cover plate itself, forming the PCB/power module. Lift this entire module carefully out of the fixture.
5. The PCB/power compartment and cable inlet compartment share one seal. Check this seal for damage. If it is damaged or brittle, it must be replaced with a new seal (available from your Martin Architectural dealer: P/N: 20600450). Cable entry is sealed for life, so replacement of this seal is the only reason ever to open the cable inlet compartment.
6. After service in the PCB/power compartment is completed, ensure that the seal and mating surfaces in the PCB/power compartment cover plate and housing are perfectly clean and dry.

**Note:** Do not apply silicone or any other type of sealant to the seal or mating surfaces. Doing so will invalidate the product warranty.

7. Lower the PCB/power module carefully into place, being careful not to damage the seal or trap wires.
8. Tighten the five PCB/power compartment cover plate Allen screws by hand until they are finger tight. Then use an Allen key to further tighten each screw by between three quarters of a turn and one full turn. Screws will now be tight enough to achieve a waterproof seal.

**Note:** Do not overtighten, or you may damage the seal and invalidate the product warranty.

9. If no further service is required, fasten a new anti-humidity sachet to the lamp module, then reinstall all components as described in this chapter before reapplying power.

## Connecting lamp leads to the starter

If it ever becomes necessary to disconnect the lamp wiring harness from the starter, make sure that the wires in the harness are reconnected to the starter as follows:

- White wire with blue sleeve to screw terminal marked **N**
- White wire without sleeve to screw terminal marked **LP**
- Wire without insulation (bare copper) and ring terminal to chassis where the ground (earth) wire was originally fastened.

## Reinstalling the lamp module

1. Remove a new anti-humidity sachet from its sealed aluminum packet and fasten it with a cable tie in the place of the existing sachet (see “*Anti-humidity sachet replacement*” on page 45). You must now close the fixture within 20 minutes.
2. Reconnect the lamp module wiring connectors.
3. Note the position of the screw in the lamp module seating in the housing. Lower the lamp module into the housing, rotating it if necessary so that the notch in the top of the lamp module engages with the screw. The lamp module is now correctly oriented.
4. If beam settings have been disturbed, readjust the beam (see “*Beam adjustment*” on page 53).

## Reinstalling the lens and front glass

**Important!** *Before reinstalling the lens and front glass, ensure that the anti-humidity sachet fastened to the lamp module has been replaced with a new item.*

**Replace any damaged seals or screws with new items.**

**The front glass seal, its seating surface in the housing, the front glass and the trim ring must all be perfectly clean and dry to maintain a waterproof seal.**

**Inspect the front glass seal for signs of damage or deterioration before refitting. Replacement front glasses and seals are available from Martin Architectural dealers (standard front glass: P/N 41700007, front glass seal: P/N 20600441).**

**Inspect the six countersunk Allen screws from the trim ring before reuse. Threads must be clean and undamaged. Two spare screws are**

**supplied with the fixture. Replacement screws are available from Martin Architectural dealers (P/N: 08111314)**

**Do not use silicone or any other kind of sealant on the front glass seal, front glass, housing or trim ring. Doing so will invalidate the product warranty.**

1. Inspect the front glass seal for damage before refitting. Replacement front glasses and seals are available from Martin dealers (standard front glass: p/n 41700007, front glass seal: p/n 20600441).
2. Reinstall any shading plates and louvered anti-glare plates that were originally installed.
3. Refit the lens by lowering it into the housing, rotating the lens if necessary so that the screw in the seating engages in the notch in the lens flange.
4. Any dirt between the front glass seal and housing or front glass seal and trim ring will prevent a proper seal and encourage moisture build-up inside the fixture, so clean the mating surfaces carefully. The trim ring overlaps the top of the fixture and any hard obstruction immediately beside the fixture will prevent the trim ring from sealing properly, so ensure that a space the diameter of the trim ring around the top of the fixture is clear at the level of the top of the housing.
5. Place the front glass complete with its seal in the top of the housing and place glass over the front glass.
6. Inspect the six countersunk Allen screws from the trim ring. Threads must be clean and undamaged. Replace any damaged screws. Two spare screws are supplied with the fixture. Replacement screws are available from Martin dealers (p/n: 08111314). To make future service easier, apply a small amount of copper-based or silicone grease to the threads of the trim ring screws.
7. See illustration on right. Gradually cross-tighten the trim ring screws in the sequence illustrated to 6 Nm (4.4 ft.-lbs.).

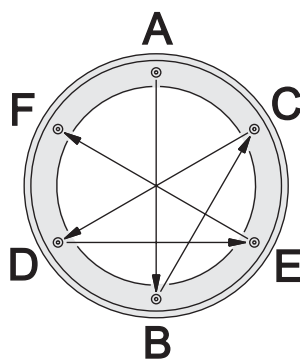

**Important!** ***Cross-tighten gradually. Do not exceed the maximum torque of 6 Nm (4.4 ft.-lbs.), or you may distort the trim ring and damage the seal. This will impair the Inground 200 CMY's waterproof properties and invalidate the product warranty.***

# 13. Set-up and adjustment

This section assumes that the Inground 200 CMY has already been commissioned. For details of powering on the fixture for the first time and test programs, see the Inground Installation Guide supplied with the product and available for download under Product Support on the Martin website at [www.martin.com](http://www.martin.com).

## Beam adjustment

---

Correct adjustment of the beam of the Inground 200 CMY is critical for correct illumination of the target. Adjustment must be carried out with the lamp powered on and is best carried out after dark.

**Warning!** *Danger of burns, electric shock and lamp explosion!*

- ***Beam adjustment must be carried out by authorized electrical personnel and in clean, dry conditions only.***
- ***Wear heat-resistant safety gloves and safety glasses throughout this procedure.***
- ***Do not look directly into the lamp.***
- ***Make sure that nothing falls into the fixture while the front glass and lens are removed.***

To adjust the beam:

1. Depending on whether the Inground 200 CMY has been in operation or not, ensure that the fixture is at optimum temperature for adjustment by following one of these two alternatives:
  - a) *If the fixture has been in operation* before you want to adjust the beam, do not switch it off. Instead, remove the front glass and lens (see “*Removing the front glass and lens*” on page 44) and wait 15 minutes for the lamp module to cool slightly.
  - b) *If the fixture has not been in operation* before you want to adjust the beam, remove the front glass and lens (see “*Removing the front glass and lens*” on page 44), apply power and wait 15 minutes for the lamp to warm up to operating temperature.

2. Loosen the two 2.5mm beam adjustment ring Allen screws (A) and rotate the lamp module until it can be tilted towards the target.

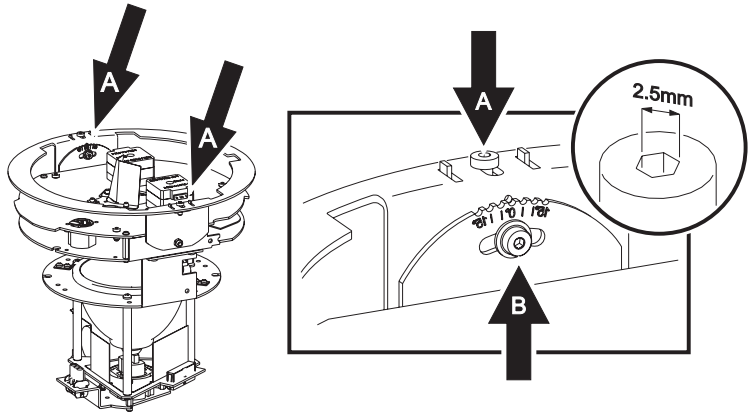

3. Make sure the beam adjustment ring screws (A) are pushed out towards the edges of the lamp module to engage the retaining clips, and retighten the screws to clamp the beam adjustment ring in place.
4. Loosen the tilt adjustment Allen screw (B) on the side of the beam adjustment ring. Adjust the tilt angle from 0 - 15° by pushing down gently on the side of the lamp module top plate closest to the target. Retighten the tilt adjustment screw (B) to lock tilt adjustment. Replace the lens.
5. Check that the target is illuminated as intended. If not, repeat step 4. When the desired illumination is obtained, the tilt angle can be read from the guide next to the tilt adjustment screw and noted for future reference.
6. Disconnect the fixture from power, lift the lens and lamp module out of the fixture temporarily to renew the anti-humidity sachet, then reinstall all components (see *“Anti-humidity sachet replacement”* on page 45, *“Reinstalling the lamp module”* on page 51 and *“Reinstalling the lens and front glass”* on page 51) before reapplying power.

# 14. Firmware updates

The latest Inground 200 CMY firmware is available free of charge from the Support area of the Martin website at <http://www.martin.com>. It can be installed using a Windows PC running the Martin Software Uploader application v. 5.5 or later (available free of charge from the Martin website) connected to the fixture or to the data link via a PC/DMX hardware interface supported by the Software Uploader application. The following devices are currently supported:

- DABS 1™ (presently available with the Martin MUM™ application)
- Martin Universal USB/DMX Interface (note that this hardware interface can be used for firmware updates but is not compatible with the Martin MUM application)
- Martin ShowDesigner™ PCI DMX Interface Card (2048 channel version)
- Martin LightJockey™ PCI DMX Interface Card (512 and 2048 channel versions)

**Note:** Intermediate control systems such as the Martin Lighting Director (MLD) and the Martin Matrix must be bypassed when updating fixture software via the DMX link. These systems do not relay the update code correctly because it is not a DMX-compliant signal.

## Normal update

To update fixture software, connect an upload device to the fixture just like a DMX controller and perform a DMX mode upload as described in the uploader's documentation. There is no need to isolate the Inground 200 CMYs from other types of fixtures on the data link.

When the upload is completed (and when booting up) the Inground 200 CMY performs a check-sum test of the memory and then resets.

In the unlikely event that a software upload is interrupted, the fixture must be powered off for at least 10 seconds to force a check-sum test. You can then repeat the DMX-mode upload. If an error occurs and the fixtures do not reset, data was interrupted or corrupted during transmission. Perform a boot sector upload as described below.

## Boot sector upload

If the normal upload procedure does not work, or if the software update notes call for a boot sector update, move the boot sector jumper at PL1 to the "Uplo" position before uploading software.

## Performing a boot sector update

1. Cut power to the lamp, allow the fixture to cool with the internal cooling fan running for at least 15 minutes, then isolate the fixture from AC power.
2. Remove the front glass, lens and lamp module (see “*Removing the front glass and lens*” on page 44 and “*Removing the lamp module*” on page 45).

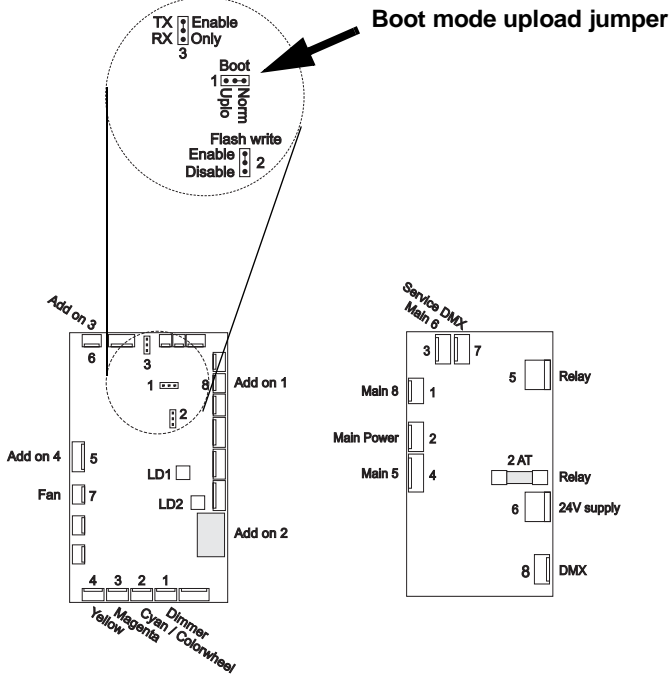

3. Open the PCB/power compartment and lift out the PCB/power module (see “*Accessing the PCB/power module*” on page 49). Turn the module upside down, so that it rests on its cover plate. Find the jumper at position JP1. Move the jumper from the Normal (pins 1 and 2) to the Upload position (pins 2 and 3).
4. Reinstall the PCB/power module and lamp module (see “*Accessing the PCB/power module*” on page 49 and “*Reinstalling the lamp module*” on page 51) and reapply power.
5. Perform a boot mode upload as described in the uploader manual.
6. When the upload is complete, isolate the fixture from power and move the jumper at JP1 back to the “Norm” position (pins 1 and 2).
7. Reinstall the PCB/power module, renew the anti-humidity sachet fastened to the lamp module, then reinstall the lamp module, lens and front glass (see “*Accessing the PCB/power module*” on page 49, “*Anti-humidity sachet replacement*” on page 45, “*Reinstalling the lamp module*” on page 51 and “*Reinstalling the lens and front glass*” on page 51).

8. Reapply power and test the fixture to check that it functions normally. If the fixture still behaves abnormally, contact your Martin supplier for advice.

# 15. Printed circuit board layout

Close-up: jumper positions

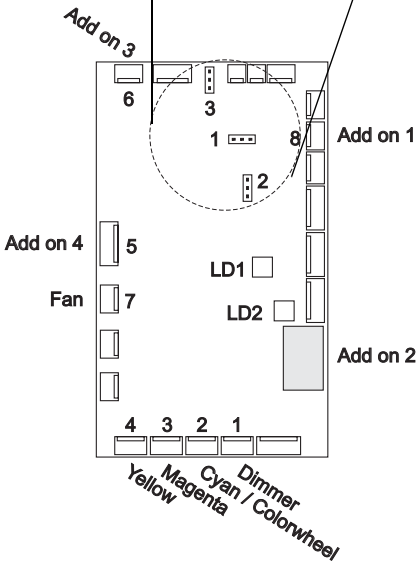
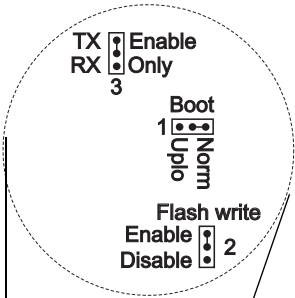

**PCB 1**

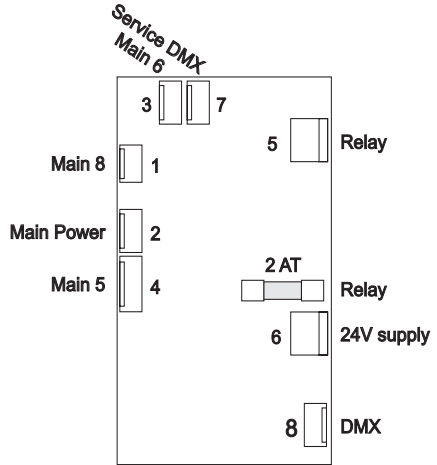

**PCB 2**

# 16. Troubleshooting

Problem	Probable cause(s)	Remedy
Excess moisture build-up in fixture (condensation under front glass).	Inadequate front glass sealing.	Ensure that front glass and trim ring make a correct seal in top of fixture housing. Check that there are no obstructions under the trim ring that may have prevented it from fastening down correctly onto the top of the housing. Ensure that trim ring screw torque is 6 Nm (4.4 ft.-lbs.). Replace front glass seal if damaged.
	Silica gel anti-humidity sachet fastened to lamp module is saturated or missing.	Install a new sachet and close fixture within 20 minutes of opening new sachet's aluminum bag
	Flooded installation well.	Improve drainage.
Fixtures cut out after 1 - 3 hours. Problem is relieved if water is poured into fill material around fixture.	Temperature too high: thermal cutout shutting down power to avoid overheating.	Modify fill material in sleeve to improve heat conduction away from fixture.
No response from fixture when power is applied.	No power to fixture.	Check power cables.
	Mains fuse blown.	Replace fuse.
Fixture resets but does not respond correctly to controller (DMX mode operation).	Controller not connected.	Connect controller.
	Incorrect addressing of the fixtures.	Check address setting on fixture and controller.
	Bad data link connection.	Inspect connections and test cables. Repair or replace as necessary.
	Conflict between tracking and vector control.	Eliminate scene cross-fade on controller or set channel 6 to 0%.
	Data link not terminated.	Insert 120 Ohm resistor across DMX terminals of last fixture.
	Defective fixture or 2 devices transmitting on link.	Check that only one fixture is set to operate as master. Bypass fixtures one at a time until normal operation is regained.
Fixture does not reset correctly.	Electronic or mechanical failure.	Contact service technician.

<b>Problem</b>	<b>Probable cause(s)</b>	<b>Remedy</b>
No light, lamp cuts out intermittently, or burns out too quickly.	Lamp blown.	Disconnect fixture and replace lamp.
	Fixture or lamp is too hot.	Allow fixture to cool. If problem persists, contact service technician.

# SECTION 6. REFERENCE

## 17.MP-2 control menu structure

The control options in the table below can be accessed after:

- connecting and powering on the MP-2
- selecting **Read Memory Card**
- scrolling to and selecting **NEG V.** followed by the software version number
- selecting **Fixture Menu** and selecting either **All addresses** or **Single Address** (in single address mode you must indicate the DMX address of the fixture you want to upload to).

Level 1	Level 2	Level 3	Level 4	Level 5	Effect (default settings bold)	
Fixture address	1-512				Select DMX address (start channel).	
Stand-alone	Enable SA	Off			Disable stand-alone operation.	
		On			Enable stand-alone operation (default setting).	
	SA Execution	Single fixture			Enable independent operation (default setting).	
		Master			Enable master operation.	
		Synchronized			Enable slave operation.	
	Light level					Not used in Inground 200 CMY
	Timer	Enable	None			Disable timer operation (default setting).
			Timer 1			Use timer 1 to trigger start/stop.
			Timer 2			Use timer 2 to trigger start/stop.
			Both Timers			Use timers 1 and 2 to trigger start/stop.
		Timer 1	Start	Hour		Set timer 1 start hour.
				Minute		Set timer 1 start minute.
			Stop	Hour		Set timer 1 stop hour.
Minute					Set timer 1 stop minute.	
Timer 2		Start	Hour		Set timer 2 start hour.	
			Minute		Set timer 2 start minute.	
		Stop	Hour		Set timer 2 stop hour.	
			Minute		Set timer 2 stop minute.	

Level 1	Level 2	Level 3	Level 4	Level 5	Effect (default settings bold)	
Stand-alone (continued)	Program	Intensity	0-255		Set dimmer level.	
		Cyan	0-255		Set cyan level.	
		Magenta	0-255		Set magenta level.	
		Yellow	0-255		Set yellow level.	
		Fade time	Pick table	Snap	Set scene fade time to zero, so that scene changes are immediate.	
				1s - 2m 0s	Set scene fade time from 1 second to 2 minutes.	
			Custom	Hours	Set scene fade time from 0 to 17 hours.	
				Minutes	Set scene fade time from 0 to 59 minutes.	
				Seconds	Set scene fade time from 0 to 59 seconds.	
		Wait (trig) time	Pick table	0s - 12h	Set scene wait time from 0 seconds to 12 hours.	
			Custom	Hours	Set scene wait time from 0 to 17 hours.	
				Minutes	Set scene wait time from 0 to 59 minutes.	
				Seconds	Set scene wait time from 0 to 59 seconds.	
		Add scene	Go		Save new scene to end of sequence.	
		Next scene	Go		Call the next scene.	
		Previous scene	Go		Call the previous scene.	
		Store scene	Go		Save changes to current scene.	
		Insert scene	Go		Save new scene before current scene.	
		Delete scene	Go		Delete the current scene.	
		Clr all scenes	No		Cancel command.	
Yes			Delete all scenes.			
Run program	Leave		Run the scenes in the program.			

Level 1	Level 2	Level 3	Level 4	Level 5	Effect (default settings bold)	
Adjust	Reset	On			Reset effects to home position.	
	Lamp on	On			Turn on lamp.	
	Lamp off	Off			Turn off lamp.	
	Real time clock		Hour			Set the current hour in 24-hour time.
			Minute			Set the current minute.
	All effects		Open			Move all effects to open position.
			Closed			Move all effects to closed position.
	Intensity		Open			Move dimmer to open position.
			Closed			Move dimmer to closed position.
	Cyan		Open			Move cyan flag to open position.
			Closed			Move cyan flag to full position.
	Magenta		Open			Move magenta flag to open position.
Closed					Move magenta flag to full position.	
Yellow		Open			Move magenta flag to open position.	
		Closed			Move magenta flag to full position.	
Personality	DMX lamp off	Off			Disable lamp dousing via DMX.	
		<b>On</b>			Enable lamp dousing via DMX (default setting).	
	DMX reset	Off			Disable fixture resetting via DMX.	
		<b>On</b>			Enable fixture resetting via DMX (default setting).	
	Auto lamp on	Off			Strike lamp from controller.	
		<b>On</b>			Strike lamp automatically within 90 seconds of power on (default setting).	
	MC-X lamp off	Off			Do not allow MC-X to douse lamp.	
		<b>On</b>			Allow MC-X to douse lamp (default setting).	
	Factory default		Factory set 1			Switch all personality settings to factory default settings 1.
			Factory set 2			Switch all personality settings to factory default settings 2.
			Factory set 3			Switch all personality settings to factory default settings 3.
			Factory set 4			Switch all personality settings to factory default settings 4.
	Reset counters		Off			Cancel resetting of all counters.
			On			Reset all counters.
Version	Leave				Not used in Inground 200 CMY.	

# 18. DMX protocol: Inground 200 CMY

DMX Channel	Value	Percent	Function
<b>1</b>	0 – 207	0 – 81	<b>Reset, Lamp On/Off</b> Reserved (no change)
	208 – 217	82 – 85	Reset fixture
	218 – 227	85 – 89	Reserved (no change)
	228 – 237	89 – 93	Lamp power on
	238 – 247	93 – 97	Reserved (no change)
	248 – 255	97 – 100	Lamp power off* <b>Note:</b> value must be held for 5 seconds
<b>2</b>	0 – 255	0 – 100	<b>Dimmer</b> Closed → open
<b>3</b>	0 – 255	0 – 100	<b>Cyan</b> White → Cyan
<b>4</b>	0 – 255	0 – 100	<b>Magenta</b> White → Magenta
<b>5</b>	0 – 255	0 – 100	<b>Yellow</b> White → Yellow
<b>6</b>	0 – 2	0 – 1	<b>Speed</b> Tracking
	3 – 245	1 – 96	Vector, fast → slow
	246 – 255	96 – 100	Fast

# 19. Specifications: Inground 200 CMY

Specifications subject to change without notice

## Physical

Height .....	496 mm (19.53 in.)
Trim ring outer Ø .....	340 mm (13.39 in.)
Trim ring thickness .....	7 mm (0.28 in.)
Housing top flange outer Ø .....	310 mm (12.2 in.)
Weight .....	approx. 20 kg (44 lb.)

## Included items

User manual, Inground 200 CMY .....	P/N 35000153
Installation guide .....	P/N 35000151
Philips CDM-SA/T 150W 942 lamp .....	P/N 97010111
Silica gel anti-humidity sachet (inside product, must be removed during installation)	
Silica gel anti-humidity sachet (separate, must be fastened in fixture during installation)	
Two spare trim ring screws (4mm Allen cap, countersunk)	

## Construction

Housing .....	Combination of extruded and high pressure die-cast aluminium
Finish .....	Black anodized
Trim ring .....	Various options available
Fasteners .....	M6 stainless steel Allen cap screws (6 off)
Front glass .....	Ø 254 mm (10 in.), 19 mm (3/4 in.) tempered optiwhite
Ingress protection factor .....	IP 65/67
AC power input .....	3 m (9.8 ft.) cable tail, hard-wired
Control data input/output .....	3 m (9.8 ft.) combined input/output cable tail, hard-wired
Front glass weight resistance (load from pneumatic tire) .....	5 000 kg (11 000 lb.)
Fixture overall weight resistance (in installation sleeve with suitable groundwork) .....	5 000 kg (11 000 lb.)

## Source

Lamp .....	150 W discharge
Base .....	G12
Approved models .....	Philips CDM SA/T 150W/942 (lifetime: 9 000 hrs.) Philips CDM-T 150W/830 (lifetime: 12 000 hrs.) Osram HCI-T 150W/WDL (lifetime: 12 000 hrs.) Osram HCI-T 150W/NDL (lifetime: 12 000 hrs.)

## Optics

Model	One-tenth peak angle
Medium.....	32°
Wide.....	56°
Very wide.....	98°
Wallwash.....	104°

## Photometrics

### Inground 200 CMY Medium

Efficiency .....	41%
Total output .....	5777 lumens
Half peak angle .....	20°
One-tenth peak angle .....	32°
Illuminance .....	50556/distance <sup>2</sup> [lux]
Half-peak diameter .....	0.35 x distance [m]
One-tenth-peak diameter .....	0.56 x distance [m]
Measurement conditions .....	230 V, 50 Hz, no color applied
Measurement source .....	Philips CDM-SA/T 150/940

### Inground 200 CMY Wide

Efficiency .....	41%
Total Output .....	5794 lumens
Half peak angle .....	32°
One-tenth peak angle .....	56°
Illuminance .....	17063/distance <sup>2</sup> [lux]
Half-peak diameter .....	0.57 x distance [m]
One-tenth-peak diameter .....	1.06 x distance [m]
Measurement conditions .....	230 V, 50 Hz, no color applied
Measurement source .....	Philips CDM-SA/T 150/940

### Inground 200 CMY Very Wide

Efficiency .....	43%
Total Output .....	5993 lumens
Half peak angle .....	54°
One-tenth peak angle .....	98°
Illuminance .....	6291/distance <sup>2</sup> [lux]
Half-peak diameter .....	1.02 x distance [m]
One-tenth-peak diameter .....	2.30 x distance [m]
Measurement conditions .....	230 V, 50 Hz, no color applied
Measurement source .....	Philips CDM-SA/T 150/940

### Inground 200 CMY Wallwash

Efficiency .....	39%
Total Output .....	5526 lumens
Half peak angle .....	54°

One-tenth peak angle .....	104°
Illuminance .....	5059/distance <sup>2</sup> [lux]
Half-peak diameter .....	1.02 x distance [m]
One-tenth-peak diameter .....	2.56 x distance [m]
Measurement conditions .....	230 V, 50 Hz, no color applied
Measurement source .....	Philips CDM-SA/T 150/940

**Control & Programming**

Control options .....	DMX-512, stand-alone, synchronized master/slave, Martin MC-X
Setting and addressing.....	Martin MUM (MP-2 if available)
Firmware update .....	Load via data link or service connector
Stand-alone trigger options .....	Internal real-time clock with 2 timers
Calculated clock precision .....	< 52 secs. +/- per month
Stand-alone memory .....	20 scenes
DMX channels .....	6

**Installation**

Minimum distance to combustible materials .....	1 m (39 in.)
Minimum distance to illuminated surfaces .....	0.5 m (20 in.)

**Thermal**

Cooling .....	Convection (with internal fan)
---------------	--------------------------------

**Maximum heat output (calculated)**

208 V, 50/60Hz .....	625 BTU/hour*
230 V, 60Hz .....	635 BTU/hour*
230 V, 50/60Hz .....	648 BTU/hour*
250 V, 50/60Hz .....	652 BTU/hour*

\* These measurements have a margin of error of +/- 10%

**Maximum power consumption**

208V, 60Hz .....	1 A, 183 W
230V, 60Hz .....	0,9 A, 186 W
230V, 50Hz .....	1 A, 190 W
250V, 50Hz .....	0.9 A, 191 W

**AC mains power**

AC mains power options.....	210 V, 60 Hz; 230 V, 50 Hz; 277 V, 60 Hz
-----------------------------	--

**Dynamic effects**

Cyan filter .....	0 - 100%
Magenta filter .....	0 - 100%
Yellow filter .....	0 - 100%
Dimmer .....	0 - 100%

**Compliance**

Ingress protection .....	IP 65/67
--------------------------	----------

# 20. Ordering information

## Spare parts

Anti-humidity sachet in sealed aluminum bag .....	P/N 37220000
Ten anti-humidity sachets in sealed aluminum bag (Service Kit).....	P/N 37220001
Front glass .....	P/N 41700007
Front glass seal .....	P/N 20600441
PCB/power compartment seal .....	P/N 20600450

## Accessories

Installation sleeve, bevelled mount .....	P/N 91611194
Installation sleeve, flush mount .....	P/N 91611215
Trim ring kit, bevelled, aluminum .....	P/N 91611210
Trim ring kit, bevelled, brass .....	P/N 91611211
Trim ring kit, flush mount, aluminum .....	P/N 91611213
Trim ring kit, flush mount, brass .....	P/N 91611214
Trim ring screw (4mm Allen cap, countersunk).....	P/N 08111314
Tamperproof hex screws (6 pcs.) and key .....	P/N 91611200
Anti-skid front glass, design etched.....	P/N 91611198
Anti-skid front glass, circular etched.....	P/N 91611238
Eyelid .....	P/N 91611201
Ring louver .....	P/N 91611202
Rock guard kit, steel .....	P/N 91611199
Rock guard kit, brass .....	P/N 91611208
Rock guard kit, aluminum .....	P/N 91611209
XLR (male 3-pin) to RJ45 cable .....	P/N 11840087

## Related items

MUM (Multi Utility Manager) incl. DABS1 interface & cables .....	P/N 90758090
--	--------------

See [www.martin.com](http://www.martin.com) for the latest ordering information for Inground fixtures and accessories



### **Disposing of this product**

Martin products are supplied in compliance with Directive 2002/96/EC of the European Parliament and of the Council of the European Union on WEEE (Waste Electrical and Electronic Equipment), as amended by Directive 2003/108/EC, where applicable.

Help preserve the environment! Ensure that this product is recycled at the end of its life. Your supplier can give details of local arrangements for the disposal of Martin products.





**Martin**<sup>®</sup>

---

[www.martin-architectural.com](http://www.martin-architectural.com) • Olof Palmes Allé 18 • 8200 Aarhus N • Denmark  
Tel: +45 8740 0000 • Fax +45 8740 0010