

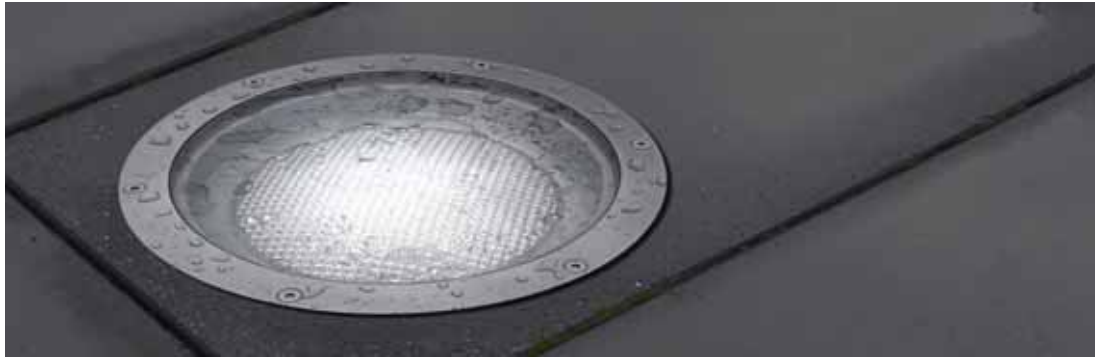

Inground 200TM



Installation Guide

IMPORTANT!

Read this guide carefully before installing the Inground 200. If the Inground 200 is not installed exactly as described in this guide, heat and/or humidity build-up may cause unsatisfactory performance or even damage that is not covered by the product warranty. If you are in any doubt about the suitability of an installation site or method, please contact Martin for advice.

Dimensions

Measurements are in millimeters

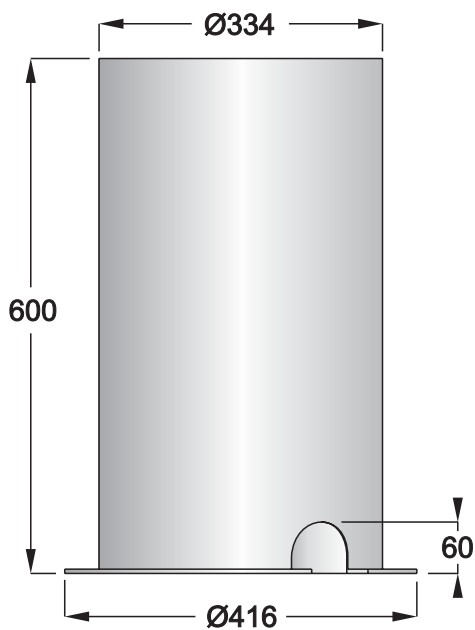
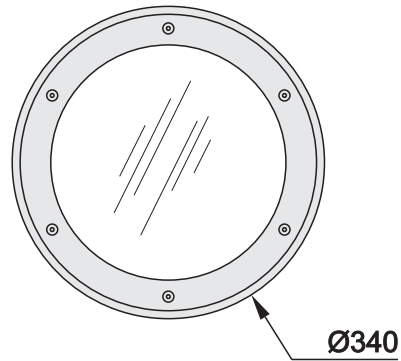
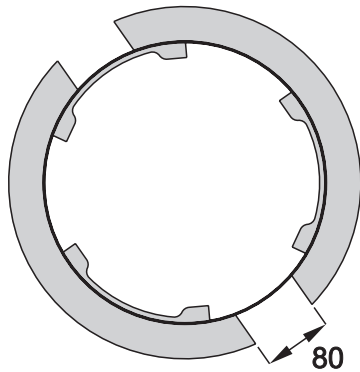

Installation sleeve

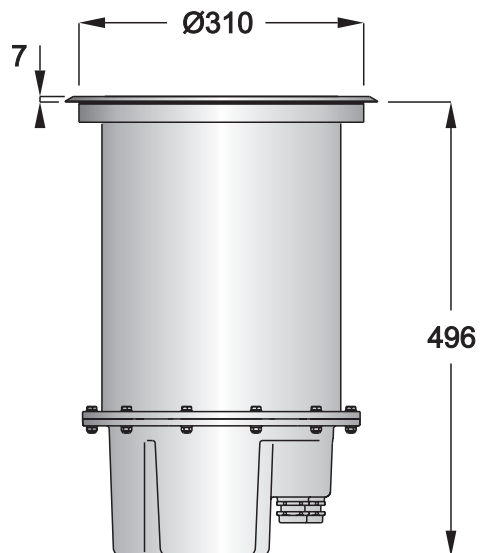

Inground 200

© 2004-2008 Martin Professional A/S. Information subject to change without notice. Martin Professional A/S and all affiliated companies disclaim liability for any injury, damage, direct or indirect loss, consequential or economic loss or any other loss occasioned by the use of, inability to use or reliance on the information contained in this manual. The Martin logo, the Martin name and all other trademarks in this document pertaining to services or products by Martin Professional A/S or its affiliates and subsidiaries are trademarks owned or licensed by Martin Professional A/S or its affiliates or subsidiaries.

Contents

1. Introduction	5
Included items	5
Overview of installation procedure	5
Exploded view	6
2. Safety precautions	7
Eliminating fire risk	7
Protecting the public	7
3. Installation precautions	8
Cooling	8
Water resistance and drainage	8
Avoiding condensation and humidity	9
Stability and weight-bearing capacity	9
Disturbance by roots	10
Service access	10
4. Physical installation	11
Safety	11
Installation options	11
5. Cable Installation	14
Power cables and connections	14
Connecting power cables	15
Control data cables and connections (Inground 200 CMY only)	15
Connecting control data cables (Inground 200 CMY only)	17
6. Powering on and commissioning	18
Commissioning procedure	18
7. Installation troubleshooting	22
8. Installation specifications	23
Inground 200™ installation sleeve instruction note	24
Installing the sleeve	24
Installing the Inground 200 in the sleeve	25
Installation sleeve specifications	27

1. Introduction

Thank you for selecting the Martin™ Inground 200™, a 150 watt upright designed for exterior burial installation.

This Installation Guide describes how to:

- prepare groundwork (installation well, etc.) before installation
- connect cables
- adjust the beam angle and have the Inground 200 ready for operation

For details of *operating and servicing* the Inground 200, please refer to the User Manual shipped with the product. The most recent versions of the User Manual and this Installation Guide are also available in the Support area of the Martin website at <http://www.martin.com>

Included items

The Inground 200 is supplied with the following items:

- Philips CDM-SA/T 150W/942 lamp (lifetime: 9 000 hours)
- Silica gel sachet inside fixture for shipping (must be removed and disposed of)
- Silica gel sachet packed separately in sealed aluminum bag (must be fastened inside fixture and fixture closed within 20 minutes of opening aluminum bag)
- DMX termination resistor
- 3 m (9.8 ft.) hard-wired power cable tail
- 3 m (9.8 ft.) hard-wired control data in/out cable tail
- Installation guide
- User manual

Overview of installation procedure

The suggested procedure for installing the Inground 200 involves two phases:

1. Pre-installation

1. Read this Installation Guide carefully to familiarize yourself with all aspects of installation before planning or starting work.
2. Ensure that a plan is available with details of site layout, beam aiming, power and control circuits, etc.
3. Prepare installation wells and/or installation sleeves.
 - see “*Physical installation*” on page 11
 - see also “*Inground 200™ installation sleeve instruction note*” on page 24
4. Lay cables
 - see “*Cable Installation*” on page 14

2. Installation

1. Connect cables.
– see “Connecting power cables” on page 15 and “Connecting control data cables (Inground 200 CMY only)” on page 17.
2. Install the fixture in the installation well or sleeve
3. Open the fixture and replace the anti-humidity sachet, then apply power.
– see “Powering on and commissioning” on page 18
4. Adjust beam and close the fixture.
– see “Beam adjustment” on page 18

Exploded view

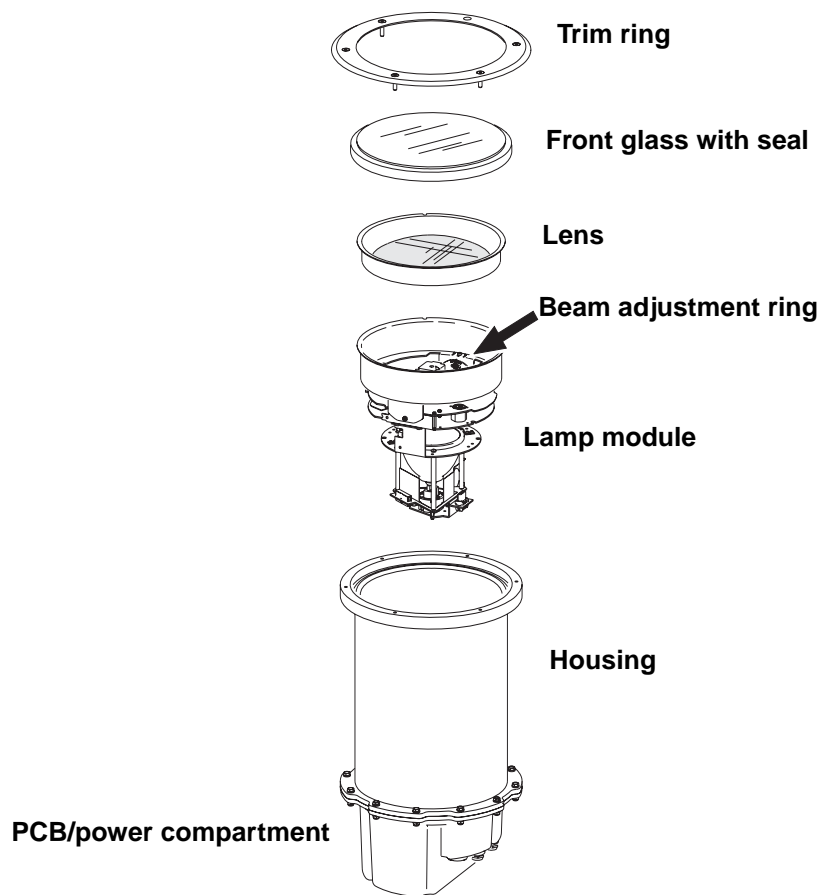

2. Safety precautions

Warning! *This product is not for household use. Installation of the Inground 200 may only be carried out by qualified professionals.*

This product presents risks of lethal or severe injury due to fire and heat, electric shock and lamp explosion.

Read this guide before installing the fixture. Follow all safety precautions listed in this guide. Observe all warnings in this guide and on the fixture.

Before attempting to operate the Inground 200, refer to the User Manual supplied with the product. The User Manual is also available in the Support area of the Martin website at <http://www.martin.com>

If you have any questions about how to install the fixture safely, please contact your Martin supplier or call the Martin 24-hour service hotline on +45 8740 0000, or in the USA on 1-888-tech-180.

Eliminating fire risk

The Inground 200 must be installed:

- Outdoors or in a well-ventilated area.
- At least 0.5 meters (20 inches) away from the surface to be illuminated.
- At least 1 meter (40 inches) away from any combustible materials.

Ensure that:

- Litter, dry leaves or other combustible materials cannot accumulate on or near the fixture.
- Vehicles or other fire risks cannot be left unattended over or near the fixture. This is particularly important in situations where a vehicle may be left unattended over or near an unlit fixture which is later switched on.

Protecting the public

To avoid injury to members of the public, install the Inground 200:

- In an area where accidental contact with the front glass is unlikely, since the Inground 200 becomes hot during normal operation.
- Flush with the surrounding surface, so as to eliminate any obstacle to pedestrians that might result in falls or injuries.
- With an anti-skid front glass (available from Martin dealers, circular etched P/N 91611238, design etched P/N 91611198) in pedestrian traffic areas.

Ensure all local safety regulations and legal requirements are observed, and take appropriate measures to warn or restrict access. To avoid accidents during installation or service, restrict access to the site and place both warning notices and barriers around all work areas until work is completed and all covers, etc. are correctly in place.

3. Installation precautions

Important! *If the Inground 200 is not installed exactly as described in this Installation Guide, product performance may be unsatisfactory and the product warranty may be invalidated. In particular, the precautions listed below must be observed. Martin will gladly provide assistance in planning and carrying out installation. In some cases, Martin must be consulted and approval obtained in order to validate the product warranty. Such cases are listed below.*

The Inground 200 installation location and method must be carefully chosen in order to avoid heat and moisture build-up and to ensure satisfactory performance over the product's lifetime.

Cooling

The Inground 200 generates heat that must be both absorbed by and conducted through the surrounding fill material as effectively as possible. If the fixture is not installed exactly as described in this guide, cooling may be insufficient and the fixture may tend to overheat.

The following precautions apply:

- Do not install the Inground 200 above ground level in the open air or in any type of container.
- Do not use fill material with a low density or insulating properties.
- Eliminate as much air as possible from the material surrounding the fixture or installation sleeve by compacting it during installation.
- If an installation sleeve is required, use only the sleeve available from Martin.
- In locations where the ambient temperature exceeds 35° C (95° F), careful heat management is necessary and you must obtain assistance from Martin to ensure satisfactory operation. In such locations, the Inground 200 product warranty is only valid after consultation with and by agreement with Martin.

Overheating will reduce the lifetimes of critical components. A thermal cutout on the PCB shuts down power to the lamp if the fixture's internal temperature exceeds safe limits. Intermittent lamp cutouts are a sign of critical overheating. Martin cannot be held responsible for intermittent lamp shutdowns or heat damage caused by an unsuitable installation method and/or location.

Water resistance and drainage

The Inground 200 has an ingress protection rating of IP 65/67. This means that the fixture can withstand immersion for 30 minutes and low-pressure water jets. However, it is not designed to withstand constant immersion.

Immersion will encourage condensation inside the fixture: a GoreTex valve in the base of the fixture equalizes pressure as the fixture heats up and cools down. The valve allows air into the fixture but prevents the entry of water. If this valve is under water while the fixture cools down, it will not be able to equalize the pressure in the fixture and humidity may be drawn past seals and into the fixture by suction.

The following precautions apply:

- The base of the Inground 200 must not be submerged in water other than for very short periods. If in doubt about a particular site, consult a geotechnical engineer.
- It must be possible for water from rain, melting snow, flooding or other sources to drain out of the installation well or sleeve *at least* as fast as it can enter it.

- To minimize the risk of flooding or waterlogging, install the fixture in a location which is above the level of the surrounding area and make sure drainage conditions are adequate.

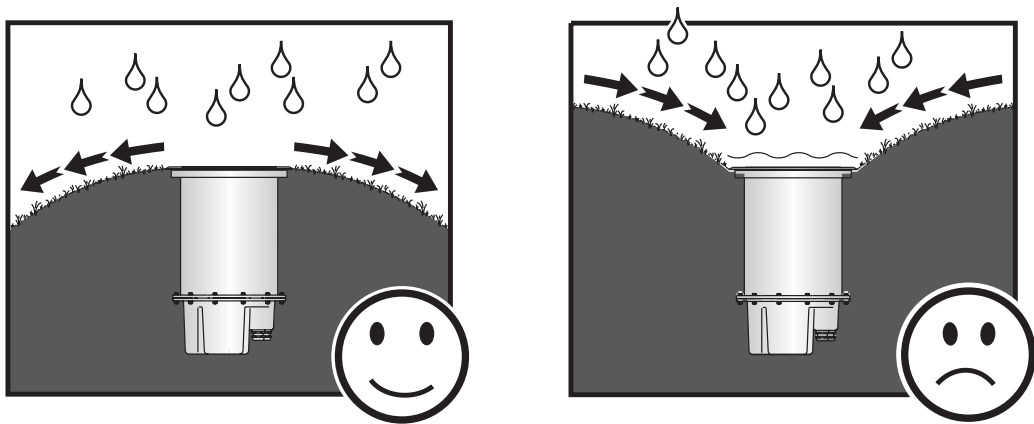

Avoiding condensation and humidity

Each time the Inground 200 is opened, the silica gel anti-humidity sachet fastened to the lamp module must be removed and a new item fastened in its place (see “*Commissioning procedure*” on page 18).

Excess humidity inside the fixture can be experienced in the following situations:

- The installation well is waterlogged
- The trim ring and front glass are not sealed correctly on the top of the housing.
- The anti-humidity sachet fastened to the lamp module is saturated or missing.

Clearing excess humidity

Warning! *If you clear excess humidity as described below:*

- ***The exposed lamp and internals present a risk of electric shock, burns and ultra-violet radiation. A hot discharge lamp is under pressure and there is a risk of lamp explosion. Block public access, wear safety glasses and heat-resistant gloves, handle the lamp module with care, and do not look into the light beam.***
- ***Choose dry weather.***
- ***Ensure that no dust or objects enter the fixture while it is open.***

If there is excess humidity in the Inground 200, condensation will appear under the front glass. To eliminate excess humidity:

1. Check that the installation has adequate drainage and that the top glass and trim ring are sealed correctly. Rectify any problems.
2. Install a new anti-humidity sachet and reinstall the front glass (see “*Commissioning procedure*” on page 18). New anti-humidity sachets are available from Martin suppliers (see “*Ordering information*” on page 23).

Stability and weight-bearing capacity

If the Inground 200 will only be subjected to light loads on the front glass, install it directly in the ground in a direct burial installation (see “*1. Direct burial*” on page 11)

If the Inground 200 is to be installed in a location where vehicles are likely to put weight on the fixture, use an installation sleeve (see “*2. Installation sleeve*” on page 12).

Disturbance by roots

The further the fixture is located from vegetation such as trees, hedges or bushes, the less chance there is that the growth of roots will disturb the fixture or even cause damage to the fixture and its cables. If the fixture is to be located close to vegetation, consult a landscape architect about the possibility of disturbance by root systems.

Service access

All internal components in the Inground 200 can be accessed through the top of the fixture without having to remove the housing from its installation site.

4. Physical installation

Safety

The Inground 200 must be installed in a location that meets the safety standards listed under “*Safety precautions*” on page 7. It is the installer’s responsibility to ensure that all local safety regulations and legal requirements are observed.

Installation options

There are two methods of installing the Inground 200:

1. Direct burial
2. Installation sleeve

1. Direct burial

Burying the Inground 200 directly in the ground is recommended:

- in landscape installations
- in locations where the top of the fixture will not have to support heavy loads (from vehicles, for example)
- in locations where the ambient temperature exceeds 25° C (77° F).

While the Inground 200 itself will bear up to 5000 kg (11,000 lb.), the ground underneath the fixture in direct burial installations may allow the fixture to sink if heavy loads are applied to the top of the fixture. In hardscape locations and in landscape locations where heavy loads may be placed on the fixture, an installation sleeve is an easy solution to ensure stability. However, if the ambient temperature exceeds 25° C (77° F), direct burial will ensure better cooling.

Direct burial: examples

The example installations below show how an Inground 200 can be buried directly, but the installer must make allowance for local conditions:

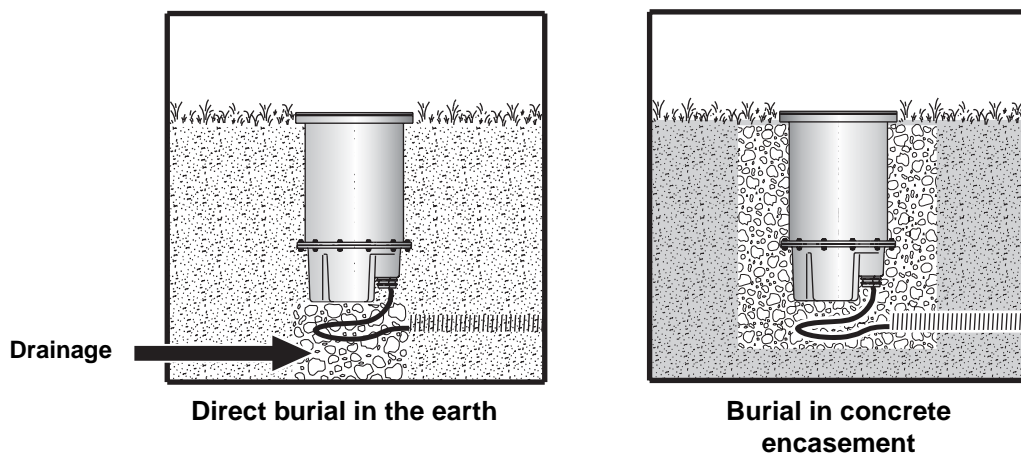

It is vital to ensure that the base of the housing rests firmly on a strong foundation, so that pressure on the top of the fixture will not press the fixture into the ground. One possible way of achieving this is to pack crushed stone or hardcore firmly in the bottom of the installation well.

Important! *When creating a strong foundation for the Inground 200, remember to allow for drainage.*

The level of the fill material immediately around the top of the housing must be kept just below the level of the top of the housing, otherwise it will create an obstruction for the trim ring. This will make it impossible to fasten the trim ring correctly onto the top of the housing to seal the product correctly, and will cause excess humidity inside the fixture.

The fill material that is in direct contact with the fixture's housing must conduct heat away from the fixture. Do not use lightweight aggregates or other insulating materials for filling, since these will encourage overheating.

If possible, install the Inground 200 in a poured concrete encasement after all connections have been made and double-checked.

Ensure that cables are not stressed or crushed during installation, and ensure that the housing rests on its base, and not on the cables.

2. Installation sleeve

A steel installation sleeve for the Inground 200 is available as an accessory. Installation instructions are supplied with each sleeve, available on the Martin website and included at the end of this guide (see "Inground 200™ installation sleeve instruction note" on page 24).

The Inground 200 in a correctly installed drive-over installation sleeve will support a weight of 5000 kg (11,000 lb.) from a vehicle tire.

Important! *The installation sleeve is not recommended in locations where the ambient temperature exceeds 25° C (77° F).*

Use of an installation sleeve is recommended for hardscape locations (tarmac, stone paving, etc.) and in landscape locations where the Inground 200 groundwork may be subjected to loads from pedestrians or vehicles (including grasscutting or gardening equipment, motorcycles, emergency services, etc.). Use of an installation sleeve will also allow work to be carried out in two stages:

1. Pre-installation (excavation, conduit-laying and groundwork preparation). This can be carried out by construction personnel.
2. Installation (cable pulling and connection, fixture installation and adjustment). This must be carried out by qualified electrical personnel only.

Sleeve installation: example

The example installation below shows how adequate support and drainage can be achieved, but the installer must make allowance for local conditions. Note that the empty space around the fixture in the illustration below must be filled with sand to complete the installation.

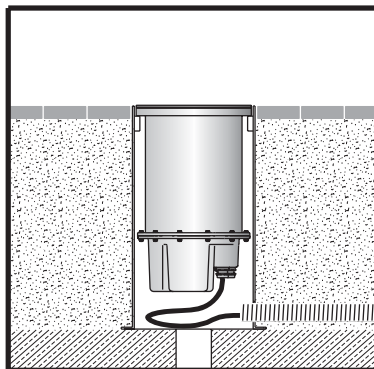

Temporary installation sleeve cover

To avoid rainwater and dirt gathering in empty installation sleeves while waiting for the Inground 200 to be installed in them, a temporary cover is supplied with each sleeve.

Important! The temporary installation sleeve cover is not designed to support weight, so ensure that pedestrians and vehicles are kept away from the sleeve by using warning notices and barriers.

5. Cable Installation

Warning! All electrical system installation must be performed by qualified professionals.

It is the installer's responsibility to ensure that all local safety regulations and legal requirements are followed when installing the Inground 200.

This section describes how to connect the Inground 200 to AC power. For Inground 200 CMY models, it also describes how to connect control data cables.

All Inground 200 models are supplied with a power cable tail installed ready for connection to mains power. Inground 200 CMY models are supplied with a data cable tail installed that contains both DMX data in and out conductors ready for connection to a control data link.

All external connections must be protected inside suitable waterproof junction boxes or as required by local laws, regulations or codes. The ends of Inground 200 cables must not be allowed to come into contact with water or moisture, as the vacuum created in the product during cooldowns can suck moisture up cable and into the fixture.

Cable slack.

Allow at least 80cm (2ft 8in) of free cable in the installation well or sleeve so that the fixture can be lifted clear for service without disconnecting cables.

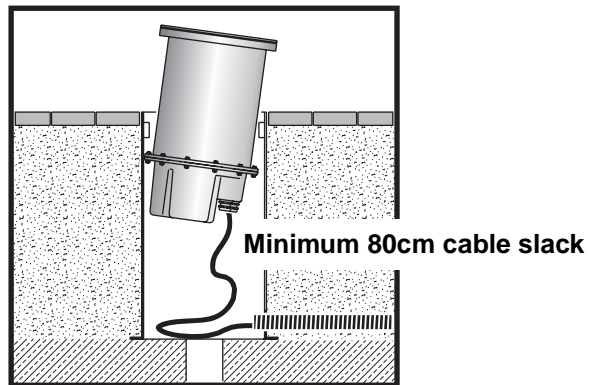

Power cables and connections

Warning! For protection from potentially lethal electric shock:

- The Inground 200 must be grounded (earthed).
- The AC power supply must be fitted with a fuse or circuit breaker, ground-fault (earth-fault) protection, and a means to isolate the fixture from power during service or when not in use.
- Cables and fixtures must be isolated from power, and steps taken to prevent reconnection, before carrying out any work on them.
- Before applying power, check the product serial label to ensure that the product can accept the local mains power voltage and frequency.

Important! Do not connect the Inground 200 to an electrical dimmer system: doing so can damage the electronics.

Power settings

The Inground 200 is factory-configured for one of the power settings listed in Table 1 below. The factory power supply settings are printed on the product serial number labels outside and inside the housing. If your local AC voltage or frequency differ from the settings for your model, the fixture's power supply must be rewired by an authorized Martin service dealer.

Voltage	Frequency
277 V	60 Hz
230 V	50 Hz
210 V	60 Hz

Table 1: Default Power Settings

Connecting power cables

Connect the conductors in the power cable tail to a source of mains power as follows:

EU models (230 V, 50 Hz models) mains power connections

- Connect the yellow/green wire to ground (earth)
- Connect the blue wire to neutral
- Connect the brown wire to live

US models (210 V, 60 Hz and 277 V, 60 Hz models) mains power connections

- Connect the yellow/green wire to ground (earth)
- Connect the black wire marked **1 - ONE** to neutral
- Connect the black wire marked **2 - TWO** to live

Table 2 below shows the standard wire identification schemes in the EU and USA; consult an electrician if you have any doubts about proper installation.



Wire (EU)	Wire (US)	Function	Marking	Screw (US)
brown	black	live	"L"	yellow or brass
blue	white	neutral	"N"	silver
yellow/green	green	ground	 or 	green

Table 2: Mains Connections

Control data cables and connections (Inground 200 CMY only)

Inground 200 CMY models require a control data link for DMX controller operation and for synchronized stand-alone operation of multiple fixtures.

Control cable type and connector pinout

Use only RS-485 (now known as EIA-485) data cable designed for burial for the data link. RS-485 cable has low capacitance and a characteristic impedance of 85 to 150 ohms. It is electrically shielded and has at least 1 twisted-pair of conductors. The minimum wire size is 0.2 mm² (24 AWG) for runs up to 300 meters (1000 ft.) and 0.322 mm² (22 AWG) for runs up 500 meters (1640 ft).

XLR connection

A male 3-pin XLR connector can be fitted at the controller end of the data link to allow a standard connection to Martin DMX controller and uploader devices. The XLR connector should be wired as follows:

- Pin 1: shield
- Pin 2: DMX data cold (-)

- Pin 3: DMX data hot (+)

Note: to avoid ground/earth loop interference, make sure the DMX cable shield does not come into contact with the shell or body of the XLR connector.

RJ-45 connection

If an RJ-45 connector is used to connect the data link to DMX controller and upload devices, it must be wired according to the 568-B system using the standard RJ-45 pin-out for DMX applications:

- Pin 1: DMX data hot (+)
- Pin 2: DMX data cold (-)
- Pins 7 and 8: shield

RJ-45 cable connector pins are numbered from the left looking at the face of the connector with the locking clip on top.

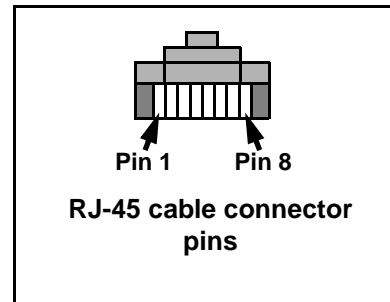

Control cable layout

The following considerations must be taken into account when planning the layout of DMX control cables:

- The maximum permitted control data cable length is 500 meters (1640 ft.). If more than 500 meters of control data cable will be necessary, contact your Martin dealer for advice.
- Long parallel runs of AC power and control data cables should be avoided. Even if not required by law, separate conduits are recommended for power and data cables.
- Fixtures must be 'daisy-chained', i.e. DMX must be connected in one single chain containing a maximum of 32 fixtures.

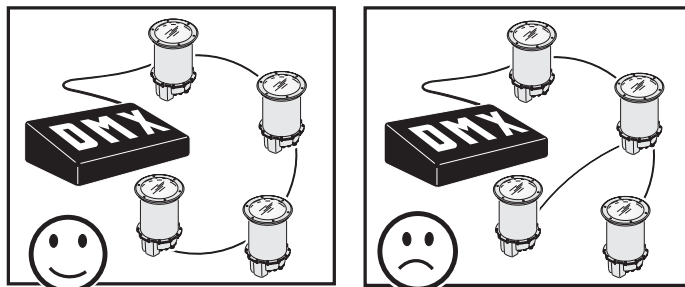

- An optically isolated amplifier-splitter such as the Martin RS-485 Opto-Splitter (P/N 90758060) must be used to:
 - extend a control data link beyond 500 meters (1640 ft.), or
 - branch the daisy-chained link into further single chains, each containing a maximum of 32 devices. The Martin Opto-Splitter allows a link to be branched into four new chains, or
 - extend the link if the maximum of 32 devices is reached.
- The last fixture on the data link (or on each chain if you have branched the link) must be terminated with a 120 Ohm DMX termination resistor (supplied with CMY fixtures and also available from Martin, P/N 04150308) connected across the data out hot (+) and data out cold (-) wires. Note that this only applies to the last fixture in the chain. No resistor should be used on the other fixtures.

Connecting control data cables (Inground 200 CMY only)

Connect the conductors in the Inground 200 CMY's data cable tail to the control data link as follows:

- Connect one white wire to data in hot (+)
- Connect the red wire to data in cold (-)
- Connect the bare copper wire to shield
- Connect the other white wire to data out hot (+)
- Connect the blue wire to data out cold (-)

It does not matter which of the white wires is used for data hot (+) input and which is used for data hot (+) output. Similarly, it does not matter which of the red and blue wires is used for data cold (-) input and which for data cold (-) output. However, we recommend that red and blue wires are connected as indicated above for reasons of consistency.

On the last fixture on the data link (or on each chain if you have branched the link), connect a DMX termination resistor across the data out hot (+) and data out cold (-) wires in the cable tail.

6. Powering on and commissioning

After all connections and cables are installed and after the site has been made safe, the Inground 200 must be opened, the anti-humidity sachet fastened to the lamp module must be replaced, then the fixture must be powered on for testing and beam adjustment, and finally the fixture must be closed.

Test sequence (CMY models only)

When fixtures are powered on, lamps strike after a short delay. When CMY models are powered on for the first time, they will run through a factory-set light show for test purposes. They will continue to run this test sequence until they are programmed.

Test sequence scenes

The Full Spectrum CMY fixture is pre-programmed with 5 scenes to verify that all CMY flags and the dimmer are working correctly:

1. White 100% intensity.
2. Cyan 100% intensity.
3. Magenta 100% intensity.
4. Yellow 100% intensity.
5. White 0% intensity (no light).

Beam adjustment

Correct adjustment of the beam of the Inground 200 is critical for correct illumination of the target. Adjustment must be carried out with the lamp powered on and is best carried out after dark.

Anti-humidity sachets

During the commissioning procedure (and each time the fixture is opened for service), the silica gel anti-humidity sachet inside the fixture must be removed and replaced with a fresh one before closing the fixture. New sachets can be obtained from Martin dealers:

- 1 sachet in sealed aluminum packet – P/N 37220000
- 10 sachets in one sealed aluminum packet (Service Kit) – P/N 37220001

The Inground 200 is supplied with one silica gel sachet fastened inside the fixture to protect from humidity during shipping and one sachet supplied separately in an aluminum foil bag.

Commissioning procedure

Warning! *Danger of burns, electric shock and lamp explosion!*

- *This procedure must be carried out by authorized electrical personnel and in clean, dry conditions only.*
- *Wear heat-resistant safety gloves and safety glasses throughout this procedure.*
- *Do not look directly into the lamp.*
- *Make sure that nothing falls into the fixture while the front glass and lens are removed.*

Important! *Any damaged seals or screws must be replaced with new items. Two spare 4mm countersunk Allen screws for the trim ring are supplied with the fixture.*

The front glass seal, its seating surface in the housing, the front glass and the trim ring must all be perfectly clean and dry during re-installation to maintain a waterproof seal.

Do not use silicone or any other kind of sealant on the front glass seal, front glass, housing or trim ring. Doing so will invalidate the product warranty.

Each time the Inground 200 is opened for service, or to clear excess humidity at any time, the silica gel anti-humidity sachet fastened to the lamp module inside the fixture must be removed and a new item fastened in its place. The fixture must then be closed within 20 minutes.

Besides safety gloves and safety glasses, you will need a torque driver with a range that includes 6 Nm (4.4 ft.-lbs.) as well as 4mm and 2.5mm Allen bits for these procedures.

To commission the Inground 200, leaving it ready for use by lighting operators:

1. Ensure that the fixture is isolated from power and that power cannot be applied, even accidentally.
2. Brush or if possible vacuum sand, dirt, etc. away and clean the top of the fixture and the surrounding area to ensure that dirt does not fall into the fixture.
3. Remove the six countersunk 4mm Allen screws and lift the trim ring off the fixture

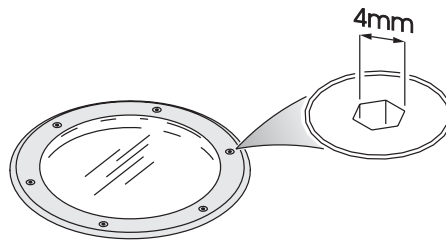

4. Taking care to avoid damaging the seal, lift off the front glass and its seal.
5. The lens is under the front glass, resting on the beam adjustment ring on top of the lamp module. Lift the lens out of the fixture.
6. If a light spill limiter ring (shading plate) and/or a louvered anti-glare plate are installed under the lens, lift them out of the fixture.
7. Holding the lamp module by the beam adjustment ring, gently lift the whole module upwards until it is clear of the housing.
8. See illustration below. Cut the cable tie holding the silica gel anti-humidity sachet to the side of the lamp module above the cooling fan and remove the sachet.

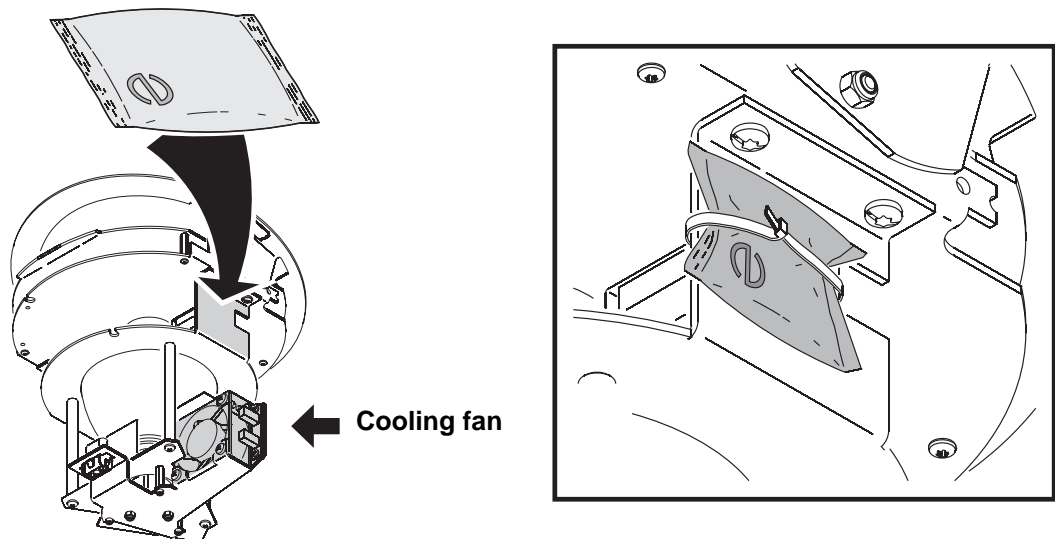

9. Remove the new anti-humidity sachet supplied with the Inground 200 from its sealed aluminum packet and fasten it with a cable tie in the place of the sachet you have removed. You must now carry out the rest of the commissioning procedure and close the fixture within 20 minutes.

10. Note the position of the screw in the lamp module seating in the housing. Lower the lamp module into the housing, rotating it if necessary so that the notch in the top of the lamp module engages with the screw. The lamp module is now correctly oriented. Power the fixture on and check that it runs its test sequence correctly.
11. Wait for a few minutes with the front glass off and the lamp powered on to allow the lamp temperature to stabilize and the fixture to reach optimum temperature for beam adjustment.
12. See illustration below. Loosen the two 2.5mm beam adjustment ring Allen screws (A) and rotate the lamp module until it can be tilted towards the target.

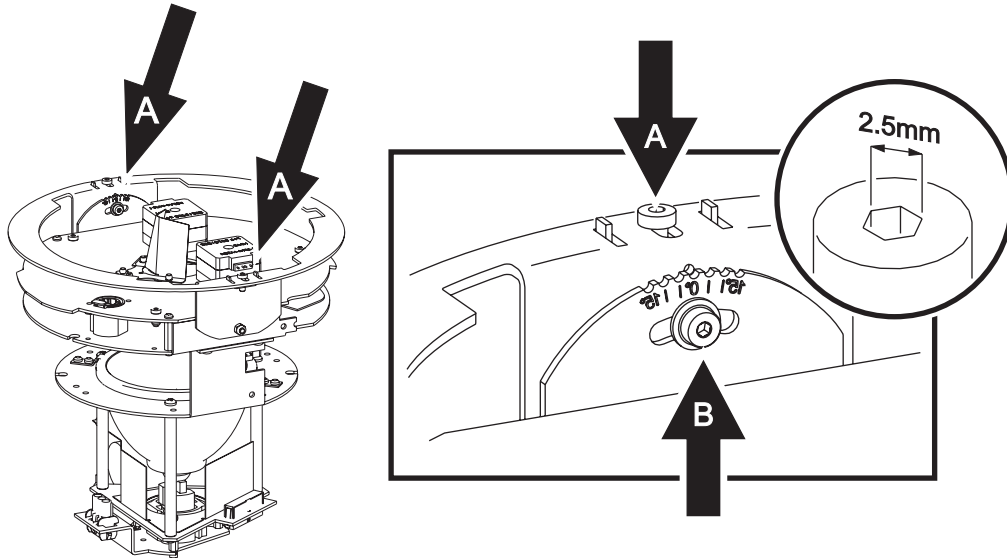

13. Make sure the beam adjustment ring screws (A) are pushed out towards the edges of the module to engage the retaining clips, and retighten the screws to clamp the beam adjustment ring in place.
14. Loosen the tilt adjustment Allen screw (B) on the side of the beam adjustment ring. Adjust the tilt angle from 0 - 15° by pushing down gently on the side of the lamp module top plate. Retighten the tilt adjustment screw (B).
15. Refit the shading plate and anti-glare plate (if fitted) and lens by lowering them into the housing, rotating the lens if necessary so that the screw in the lens seating in the top of the lamp module engages in the notch in the lens flange.
16. Check that the target is illuminated as intended. If not, repeat the readjustment procedure. When the desired illumination is obtained, the tilt angle can be read from the guide next to the tilt adjustment screw and noted for future reference.
17. Power the fixture off.
18. Inspect the front glass seal for damage before refitting. Replacement front glasses and seals are available from Martin dealers (standard front glass: p/n 41700007, front glass seal: p/n 20600441).
19. Any dirt between the front glass seal and housing or front glass seal and trim ring will prevent a proper seal and encourage moisture build-up inside the fixture, so clean the mating surfaces carefully. The trim ring overlaps the top of the fixture and any hard obstruction immediately beside the fixture will prevent the trim ring from sealing properly, so ensure that a space the diameter of the trim ring around the top of the fixture is clear at the level of the top of the housing.
20. Place the front glass complete with its seal in the top of the housing and place the trim ring over the front glass.
21. Inspect the six countersunk Allen screws from the trim ring. Threads must be clean and undamaged. Two spare screws are supplied with the fixture. Replacement screws are available from Martin dealers (p/n: 08111314). To make future service easier, apply a small amount of copper-based or silicone grease to the threads of the trim ring screws.

22. See illustration below. Gradually cross-tighten the trim ring screws in the sequence illustrated to 6 Nm (4.4 ft.-lbs.).

Important! *Do not exceed a torque of 6 Nm (4.4 ft.-lbs.), or you may distort the trim ring and damage the seal. This will impair the Inground 200's waterproof properties and invalidate the product warranty.*

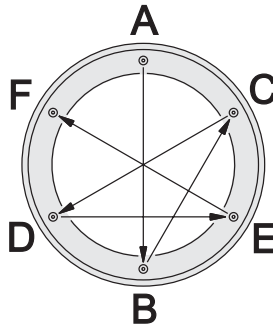

7. Installation troubleshooting

Problem	Probable cause(s)	Remedy
Excess moisture build-up in fixture (condensation under front glass).	Inadequate front glass sealing.	Ensure that front glass and trim ring make a correct seal in top of fixture housing. Check that there are no obstructions under the trim ring that may have prevented it from fastening down correctly onto the top of the housing. Ensure that trim ring screw torque is 6 Nm (4.4 ft.-lbs.). Replace front glass seal if damaged.
	Silica gel anti-humidity sachet fastened to lamp module is saturated or missing.	Install a new sachet and close fixture within 20 minutes of opening new sachet's aluminum bag
	Flooded installation well.	Improve drainage.
Fixtures cut out after 1 - 3 hours. Problem is relieved if water is poured into fill material around fixture.	Temperature too high: thermal cutout shutting down power to avoid overheating.	Modify fill material in sleeve to improve heat conduction away from fixture.
No response from fixture when power is applied.	No power to fixture.	Check power cables.
	Mains fuse blown.	Replace fuse.
No light, lamp cuts out intermittently, or burns out too quickly.	Lamp blown.	Disconnect fixture and replace lamp.
	Fixture or lamp is too hot.	Allow fixture to cool. If problem persists, contact service technician.
Fixture resets but does not respond correctly to DMX controller (CMY models only).	Controller not connected.	Connect controller.
	Incorrect addressing of the fixtures.	Check address setting on fixture and controller.
	Bad data link connection.	Inspect connections and test cables. Repair or replace as necessary.
	Conflict between tracking and vector control.	Eliminate scene cross-fade on controller or set channel 6 to 0%.
	Data link not terminated.	Insert 120 Ohm resistor across DMX output conductors of data cable of last fixture on link.
	Defective fixture or 2 devices transmitting on link.	Check that only one fixture is set to operate as master. Bypass fixtures one at a time until normal operation is regained.
Fixture does not reset correctly (CMY models only).	Electronic or mechanical failure.	Contact service technician.

8. Installation specifications

Dimensions

Height	496mm (19.53in.)
Trim ring outer Ø	340mm (13.39 in.)
Trim ring thickness	7mm (0.28 in.)
Top flange outer Ø	310mm (12.2 in.)

Included Items

User manual, Inground 200	P/N 35000153
Installation guide.....	P/N 35000151
Philips CDM-SA/T 150W 942 lamp.....	P/N 97010111
Silica gel anti-humidity sachet (inside product, must be removed during installation)	
Silica gel anti-humidity sachet (separate, must be fastened in fixture during installation)	
Two spare trim ring screws (4mm Allen cap, countersunk)	

Weight-bearing capacity

Front glass (load from pneumatic tire)	5000 kg (11,000 lb.)
Inground 200 in installation sleeve with suitable groundwork	5000 kg (11,000 lb.)

Connections

AC power in	3 m (9 ft. 10 in.) cable tail
Control data in/out	3 m (9 ft. 10 in.) cable tail, 5-conductor data in/out

Related items

MUM (Multi Utility Manager) incl. DABS interface & cables	P/N 90758090
-----------------------------------------------------------------	--------------

Ordering information

Anti-humidity sachet in sealed aluminum bag	P/N 37220000
Ten anti-humidity sachets in sealed aluminum bag (Service Kit)	P/N 37220001
Front glass	P/N 41700007
Front glass seal	P/N 20600441
Connections compartment/power compartment seal	P/N 20600450
Installation sleeve, bevelled mount	P/N 91611194
Installation sleeve, flush mount	P/N 91611215
Trim ring kit, bevelled, aluminum	P/N 91611210
Trim ring kit, bevelled, brass	P/N 91611211
Trim ring kit, flush mount, aluminum	P/N 91611213
Trim ring kit, flush mount, brass	P/N 91611214
Trim ring screw (4mm Allen cap, countersunk).....	P/N 08111314
Tamperproof hex screws (6 pcs.) and key	P/N 91611200
Anti-skid front glass, design etched.....	P/N 91611198
Anti-skid front glass, circular etched.....	P/N 91611238
Eyelid	P/N 91611201
Ring louver	P/N 91611202
Rock guard kit, steel	P/N 91611199
Rock guard kit, brass	P/N 91611208
Rock guard kit, aluminum	P/N 91611209

For full product specifications and ordering information, please refer to the User Manual. Constantly updated information is also available on the Martin website at <http://www.martin-architectural.com>

Inground 200™ installation sleeve instruction note

The Inground 200 installation sleeve is recommended for hardscape locations and all locations with vehicle traffic. It is not recommended for locations where the ambient temperature exceeds 25° C (77° F). Sleeves are supplied in either flush or bevelled mount models. The flush mount model is recommended for areas with traffic.

Warning! *Ensure that supply cables cannot be connected to AC power during installation.*

The sleeve is supplied with this instruction note, 3 clamps and a steel cover/guide plate for use while filling the sleeve.

Installing the sleeve

To install the Inground 200 installation sleeve:

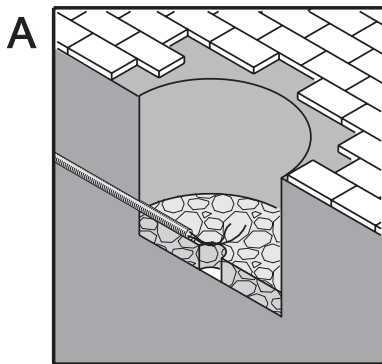

Prepare the groundwork. Test to ensure adequate drainage. Ensure that the foundation will withstand loads on the fixture (from vehicles, for example).

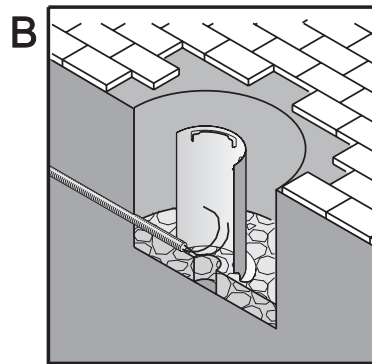

Put the sleeve in position. Cutouts are provided for cable conduit. Place a straightedge across the top of the sleeve and adjust height so that the sleeve will be flush with the finished surrounding surface.

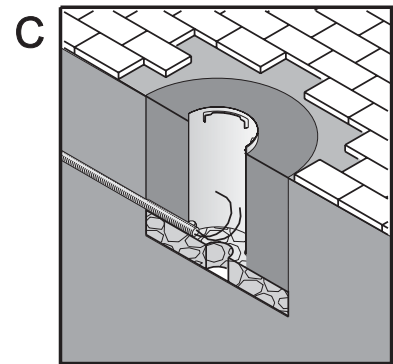

Fill around the sleeve. Earth or poured concrete are suitable. If filling with earth, compress it in layers during filling so that the earth is as compact as possible.

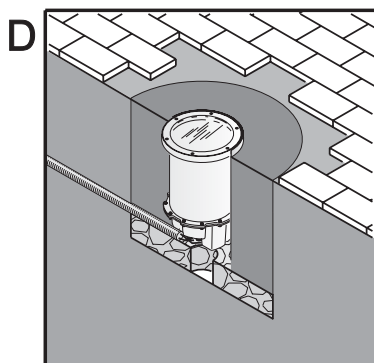

Install the fixture in the sleeve (see instructions on next page).

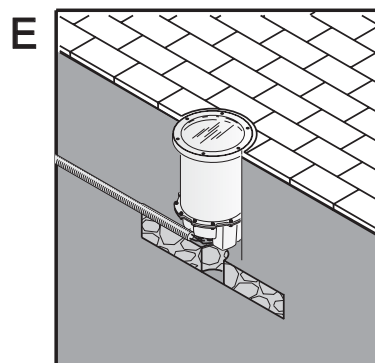

Finish the surface around the fixture (flush mount model illustrated).

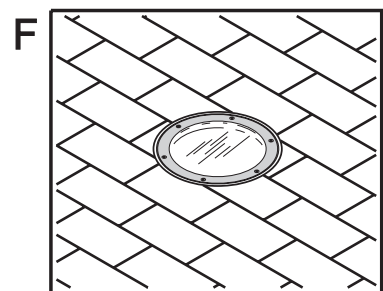

The finished installation.

Installing the Inground 200 in the sleeve

This procedure must be carried out by an authorized electrician.

Ensure that cables cannot be connected to AC power during installation.

Use of a vacuum cleaner is recommended for some parts of this procedure.

Approximately 40 kg (88 lb.) of oven-dried fine sand that conforms to the following specifications is required as fill material in each installation sleeve:

- Density..... 1500-1600 kg/m³ (94-100 lb./cu.ft.)
- Grain size..... 0.18-0.5 mm (0.007-0.020 in.)

Suitable sand can be obtained locally or ordered from Martin in 25 kg (55 lb.) bags (P/N 91611237).

To install the Inground 200 in an installation sleeve:

1. Remove the Inground 200's front glass, lens and lamp module as described in the Installation Guide.
2. Place the fixture next to the installation sleeve. Connect all cables, tighten cable glands and tighten any blanking plugs used as described in the Installation Guide.

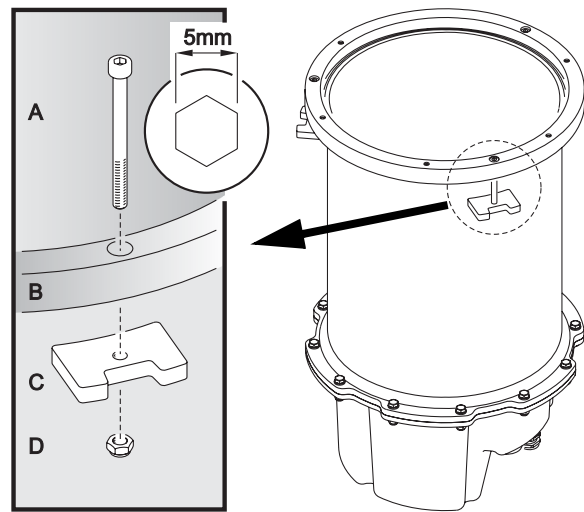

The installation sleeve is supplied complete with 3 clamps to hold the fixture in the sleeve (see illustration above). Clamp the Inground 200 into the sleeve as described below:

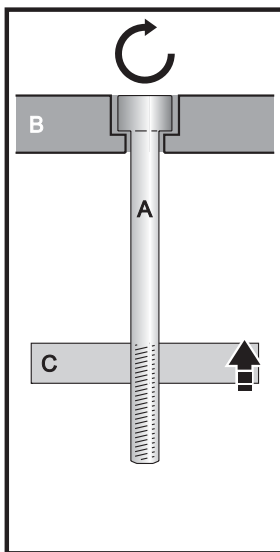

3. Pass a 5mm Allen cap clamp bolt (A) through one of the three recessed holes in the top of the housing (B) and screw the bolt through a clamp block (C).

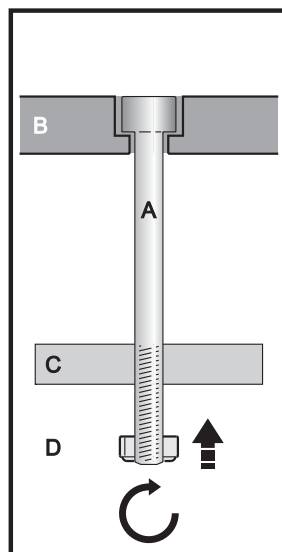

4. Screw a self-locking retaining nut (D) onto the end of the clamp bolt until the nut is flush with the end of the bolt.

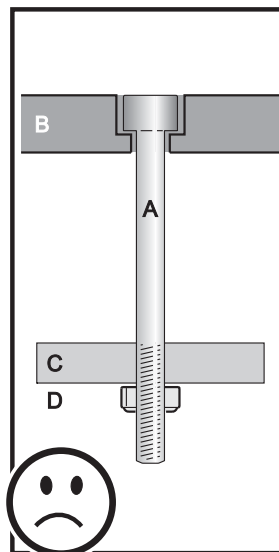

5. Do not screw the nut any further up the bolt.

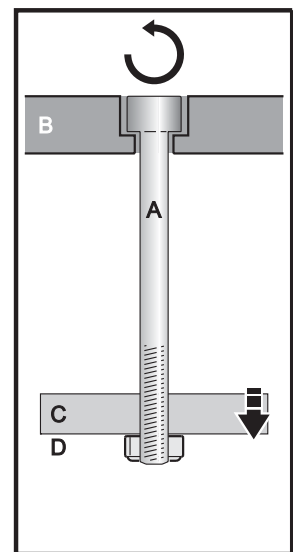

6. Unscrew the bolt back up through the clamp block until the retaining nut touches the clamp block.

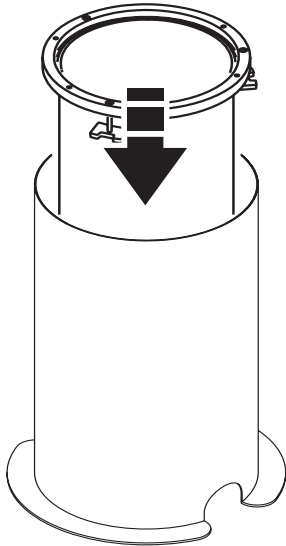

7. Holding the Inground 200 by the inside rim of the housing, begin lowering it into its sleeve.

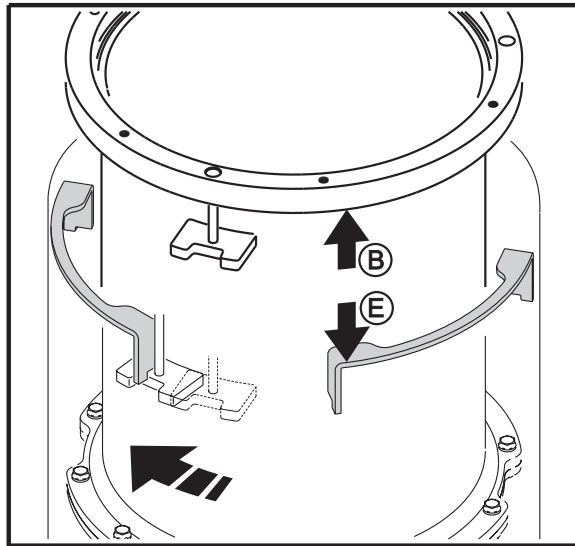

8. As you lower the Inground 200, ensure that the clamp blocks (C) pass between the fins in the sleeve so that the outer rim (B) sits on the fins (E). Then rotate the Inground 200 so that the clamp blocks locate under the fins.

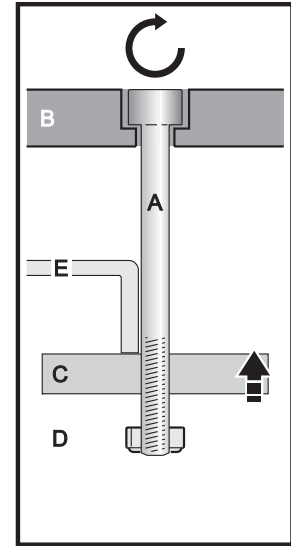

9. Tighten the three clamp bolts (A) finger tight only.

10. Screw on the trim ring to center the fixture in the sleeve, then remove the trim ring again and fully tighten the clamp bolts (A)

Ensure that the Inground 200 is correctly centered in the sleeve and that the front glass seal seats correctly before adding fill material.

11. With the fixture installed and clamped in place, fill the remaining space in the installation sleeve with oven-dried fine sand as described below. The sand must have a density of 1500-1600 kg/m³ (94-100 lb./cu.ft.) and grain size 0.18-0.5 mm (0.007-0.020 in.). One installation sleeve will accept approximately 40 kg (88 lb.) of sand.

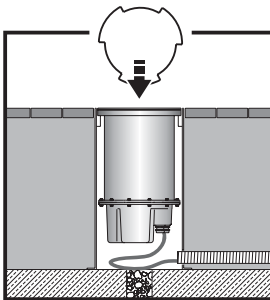

12. Put the plate supplied with the installation sleeve on the Inground 200. Rotate the plate so that sand can run through the three cutouts into the bottom of the sleeve.

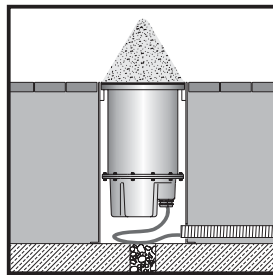

13. Tip sand onto the plate and guide it down between the cutouts in the plate and into the sleeve.

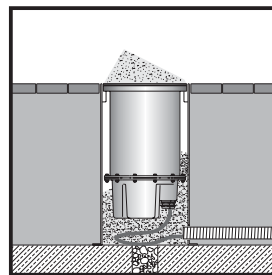

14. Fill as much sand as possible into the sleeve, packing it as tightly as possible. When the sleeve appears full, pour water into it to help the sand settle. Add sand as necessary.

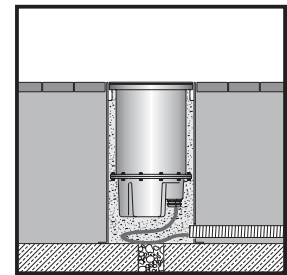

15. Remove remaining sand from the plate with a vacuum cleaner and remove the plate. Remove any sand from inside the fixture and from the top glass sealing surface, and ensure there is clearance for the trim ring around the top of the fixture.

Use only sand of the specified type as fill material, or the fixture may tend to overheat.

The Inground 200 is now ready for internal components to be installed as described in the Installation Guide and product manuals.

Installation sleeve specifications

Dimensions

Height 600mm (23.6 in.)
External diameter of tube 330mm (13 in.)
Base flange diameter 410mm (16.2 in.)

Construction

Acid-resistant stainless steel

Weight-bearing capacity

Installation sleeve with suitable groundwork 5000 kg (11,000 lb.)

Thermal

Max. recommended ambient temperature (Ta) 25° C (77° F)

Included items

Instruction note P/N 35000566
Clamp set (3 x 5mm M6 Allen hex cap clamp bolts, 3 x clamp blocks, 3 x 10mm M6 self-locking nuts)
Sleeve fill guide/cover plate

Accessories

Oven-dried fine beach sand, 25 kg (55 lb.) bag..... P/N 91611237

Ordering information

Installation sleeve, bevelled mount P/N 91611194
Installation sleeve, flush mount P/N 91611215

Installation sleeve instruction note: p/n 35000566
©Martin 2005-2008



www.martin.com • Olof Palmes Allé 18 • 8200 Aarhus N • Denmark
Tel: +45 8740 0000 • Fax +45 8740 0010