

User Instructions

US-2002

Intercom User Station

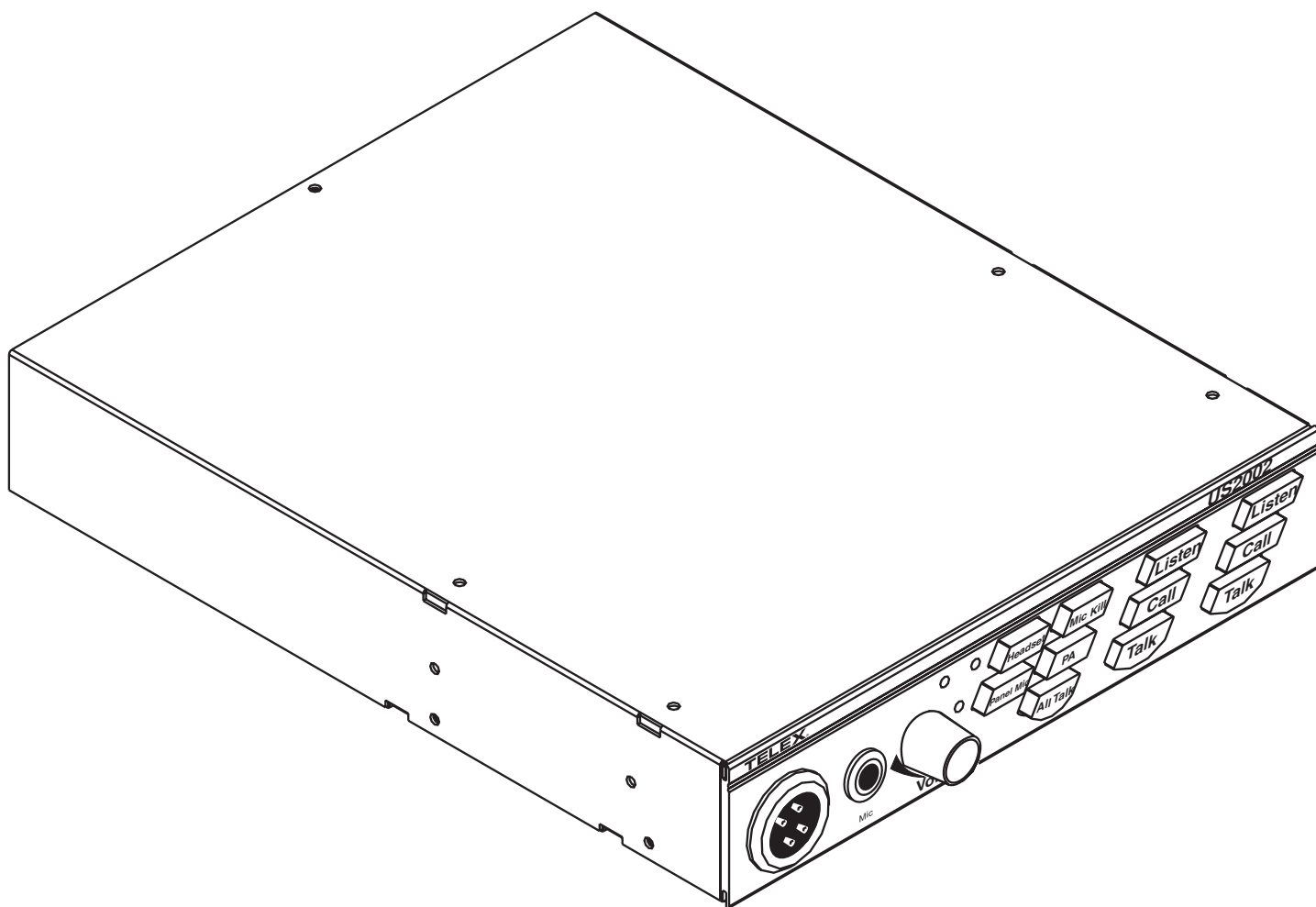

PROPRIETARY NOTICE

The product information and design disclosed herein were originated by and are the property of Telex Communications, Inc. Telex reserves all patent, proprietary design, manufacturing, reproduction, use and sales rights thereto, and to any article disclosed therein, except to the extent rights are expressly granted to others.

COPYRIGHT NOTICE

Copyright 2006 by Telex Communications, Inc. All rights reserved. Reproduction, in whole or in part, without prior written permission from Telex is prohibited.

WARRANTY NOTICE

See the enclosed warranty card for further details.

CUSTOMER SUPPORT

Technical questions should be directed to:

Customer Service Department
RTS/Telex Communications, Inc.
12000 Portland Avenue South
Burnsville, MN 55337 USA
Telephone: 800-392-3497
Fax: 800-323-0498
Factory Service: 800-553-5992

RETURN SHIPPING INSTRUCTIONS

Customer Service Department
Telex Communications, Inc. (Lincoln, NE)
Telephone: 402-467-5321
Fax: 402-467-3279
Factory Service: 800-553-5992

Please include a note in the box which supplies the company name, address, phone number, a person to contact regarding the repair, the type and quantity of equipment, a description of the problem and the serial number(s).

SHIPPING TO THE MANUFACTURER

All shipments of product should be made via UPS Ground, prepaid (you may request from Factory Service a different shipment method). Any shipment upgrades will be paid by the customer. The equipment should be shipped in the original packing carton. If the original carton is not available, use any suitable container that is rigid and of adequate size. If a substitute container is used, the equipment should be wrapped in paper and surrounded with at least four (4) inches of excelsior or similar shock-absorbing material. All shipments must be sent to the following address and must include the Proof of Purchase for warranty repair. Upon completion of any repair the equipment will be returned via United Parcel Service or specified shipper, collect.

Factory Service Department
Telex Communications, Inc.
8601 East Cornhusker Hwy.
Lincoln, NE 68507 U.S.A.
Attn: Service

FCC STATEMENT

This equipment uses and can radiate radio frequency energy that may cause interference to radio communications if not installed in accordance with this manual. The equipment has been tested and found to comply with the limits of a Class A computing device pursuant to Subpart J, Part 15 of FCC Rules which are designed to provide reasonable protection against such interference when operated in a commercial environment. Operation of this equipment in a residential area may cause interference which the user (at his own expense) will be required to correct.



This product meets Electromagnetic Compatibility
Directive 89/336/EEC.

TABLE OF CONTENTS

Chapter 1	
Introduction	3
What's New with the US2002	3
Description	3
Features	4
Chapter 2	
Installation	7
Unpacking	7
Configuration Pre-check	7
Headset Microphone Type Selection Dip Switch	8
Mic Kill Send Enable DIP Switch	8
Program Interrupt DIP Switches	9
Monaural or Binaural Operation DIP Switches	9
For Monaural operation with headphones or one speaker (factory default):	9
For binaural operation with 2 speakers:	9
Balanced / Unbalanced Switch (SW2)	9
Direct Program Listen Enable / Disable Jumpers	10
Mounting Configurations	10
Connections	11
Central Master Station vs. Remote Station	11
All Locally Powered Stations	11
External Program Input and PA Output	11
ES4000A Expansion Station Connection (Optional Component)	11
Cables	11
Chapter 3	
Operation	25
Power-Up Check	25
Test Tone	25
Sidetone Adjustment	25
Voice-Activated Microphone (Vox) Setup	27
Operation	27
Normal vs. Programming Mode	27
Volume Adjustment	27
Receiving Calls	27
Calling an Intercom Channel	28
Microphone Mute During Talk	28
All Talk	28
Public Address (PA)	28
Turning the Program Inputs ON and OFF	29
Using Mic Kill	29
Using Voice-Activated Microphone (Vox)	29
Incoming Call Beep On/Off	29
Specifications	30

TABLE
OF
CONTENTS

Thank you for purchasing the Audiocom US2002 Intercom User Station. We hope the many design features of this product will satisfy your intercommunication requirements for many years to come. To get the most out of your new intercom stations, please take a few moments to look through this booklet before using the US2002 for the first time.

What's New with the US2002

- New internal mechanical design in the panel mic to standardize and improve connections.
- Updated gooseneck mic plug connection from a pin connector to a stereo plug for easy installation.
- The Telex model MCP-90-XX microphone replaces the EGM-12N and EGM-18N microphone.

Description

The US2002 Intercom User Station is designed for stationary use by personnel who may require selective access to two or more intercom channels. It can be rack mounted or used as a desktop station. For rack mounting, optional hardware is required. For desktop use the four rubber feet supplied.

The US2002 can be used as a simple, multi-channel user station. Typically, in this application, no program sources or public address output are connected and some advanced features can be disabled: the station simply provides talk, listen and call capability for a single user. Alternatively, the US2002 can function as a master station. In this configuration, most or all advanced features are activated. Also, program inputs and public address output may be connected. This configuration is ideal for command and control personnel such as directors, supervisors, etc.

The basic US2002 can communicate with two intercom channels. This number can be increased by connecting optional ES4000A Expansion Stations. Each ES4000A adds four additional channels, and up to four of these expansion stations can be connected for a total of eighteen channels.

Features

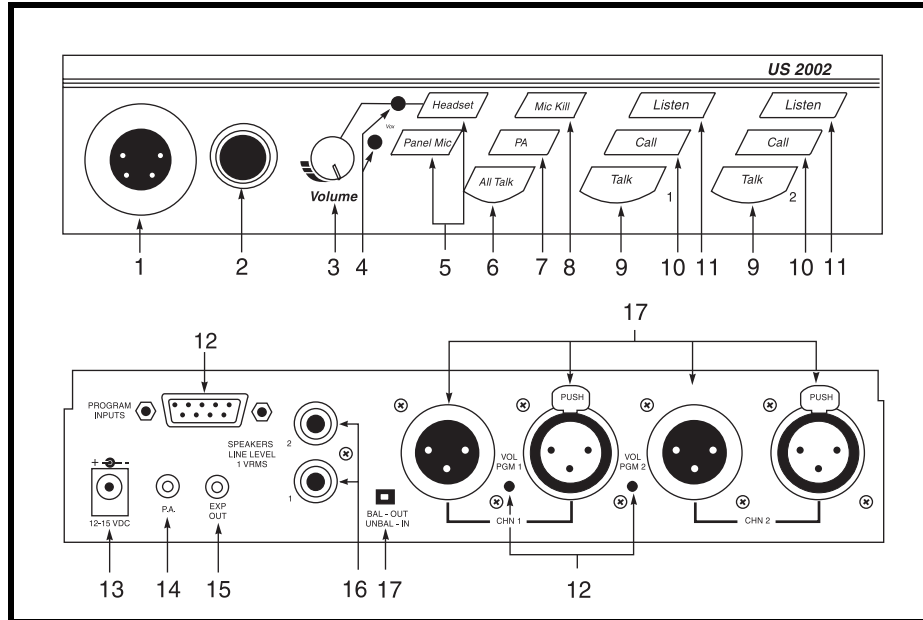

FIGURE 1. US2002 Reference View (See numbered features, following)

1. *Dynamic-Mic Headset Connector* - Accepts headset with monaural headphones and either balanced or unbalanced dynamic microphones.
2. *Panel Mic / Electret Mic Headset Connector* - Accepts an electret gooseneck microphone, such as the Telex Model MCP-90-XX. The Model MCP-90 series panel mic connector is a 1/4" stereo plug, with a threaded shaft for easy installation.
3. *Volume Control* - Adjusts headphone volume only. If an external speaker is used, volume is adjusted at the speaker.
4. *Vox Trimmers* - Used with the voice-activated microphone feature. Separate trimmers adjust the voice activation level for the headset and panel microphones.
5. *Headset and Panel Mic Keys* - Used to manually activate either the headset or panel microphone, whichever is being used.
6. *All Talk Key* - Used to talk to all stations that are listening on all channels. This includes both US2002 channels and any connected ES4000A Expansion Stations.
7. *PA Key* - If the US2002 is connected to a public address system, this key may be used to talk over the public address system.
8. *Mic Kill Key* - Used to turn OFF the microphones on any intercom stations on a channel. Also used to activate the program inputs and the audible beep feature for incoming calls.
9. *Intercom Talk Keys* - Momentary or latching (hands-free) operation possible.
10. *Call Keys* - Used to place calls on intercom channels and to indicate incoming calls.
11. *Intercom Listen Keys* - Momentary or latching operation possible.
12. *Program Inputs Connector and Trimmers* - Each intercom channel has its own program input and level adjust trimmer. The program inputs may be turned ON or OFF via the front panel and they may be set to interrupt during talk, if desired.
13. *Local Power Jack* - An optional PA-KP local power supply can be connected to power the US2002 from an AC outlet, instead of from the intercom channels.
14. *PA Output* - Connects to a public address system.
15. *Expansion Out Connector* - Connects to an ES4000A Expansion Station.
16. *Speaker Output Jacks* - A single powered loudspeaker or dual powered loud speakers may be connected for monaural or binaural listening.

17. Intercom Channel Connectors and Audiocom / Clear-Com¹ Selector Switch - Two connectors are provided for each channel for loop-through connection of multiple intercom stations. The selector switch sets the US2002 for compatibility with either Audiocom or Clear-Com channel connector pin-outs, channel power requirements, and call signaling requirements.

1. Brand names mentioned are the property of their respective companies.

Unpacking

The package contains the following items. Contact the shipper or your Audiocom dealer immediately if anything is damaged or missing. Detach and fill out the registration card and return it to Telex to properly register your US2002.

Quantity	Description
1	US2002 Intercom Station
1	Warranty and Registration Card
1	User Manual
4	Rubber feet for desktop use of the US2002
1	Termination plug for special applications (Figure 13 on page 22)

Configuration Pre-check

Before connecting the US2002 make sure it is properly configured for your intended usage. Figure 2 on page 8 shows the locations of the configuration jumpers and switches. To access internal switches and jumpers, remove one screw from the top cover and three screws from each side. Note, switch SW2 can be accessed through the back panel.

NOTE: If you change any switch settings while the US2002 is operating, you must perform a reset: either cycle power OFF then ON, or simultaneously press the **All Talk** and **Listen 1** keys, then release them. The sidetone controls are adjusted after power-up and are normally accessed through the bottom cover.

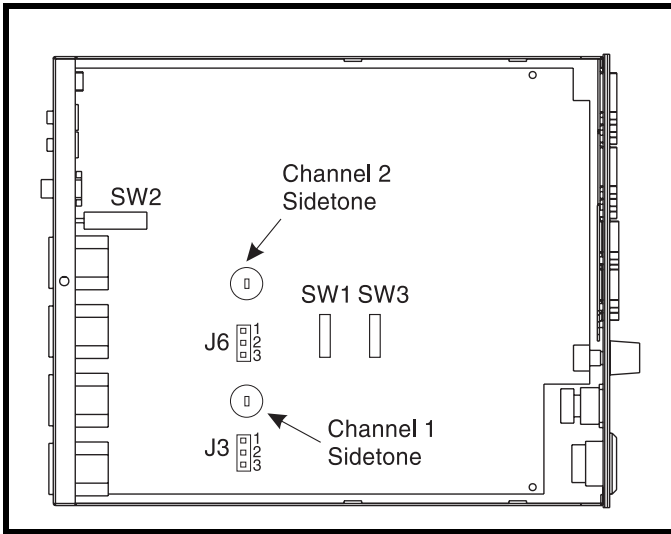

FIGURE 2. Locations of Configuration Jumpers and Switches

TABLE 1. Configuration Switch Settings

SWITCH NUMBER	DESCRIPTION	SETTINGS	DEFAULT SETTINGS
DIP Switch SW1 (Internal)			
SW1-1	Headset microphone type	On: Unbalanced Off: Balanced (typical)	Off
SW1-2	Call signal send, channel 1	On: Enabled Off: Disabled	On
SW1-3	Call signal receive, channel 1	On: Enabled Off: Disabled	On
SW1-4	Call signal send, channel 2	On: Enabled Off: Disabled	On
SW1-5	Call signal receive, channel 2	On: Enabled Off: Disabled	On
SW1-6	Mic kill signal send	On: Enabled Off: Disabled	Off
SW1-7	Program 2 interrupt	On: Interrupt during talk Off: No Interrupt	Off
SW1-8	Program 1 interrupt	On: Interrupt during talk Off: No Interrupt	Off
Push-button Switch SW2 (BAL-UNBAL switch on Back Panel)			
	Audiocom or Clear-Com operation	Out: Audiocom (balanced) In: Clear-Com Unbalanced.	Out
Dip Switch SW3 (internal)			
SW3-1	Incoming call beep	On: Disabled Off: Enabled	Off

TABLE 1. Configuration Switch Settings

SWITCH NUMBER	DESCRIPTION	SETTINGS	DEFAULT SETTINGS
SW3-2	Listen 1 to speaker 1 only	On: Enabled (Binaural) Off: Disabled (Monaural)	Off
SW3-3	Incoming call beep, speaker 1	On: Enabled (SW3-1 must be off) Off: Disabled	Off
SW3-4	Incoming call beep, speaker 2	On: Enabled (SW3-1 must be off) Off: Disabled	Off
SW3-5	Listen 2 to right headphone	On: Enabled (Binaural) Off: Disabled (Monaural)	On
SW3-6	Listen 2 to speaker 2	On: Enabled (Binaural) Off: Disabled (Monaural)	Off
SW3-7	Listen 2 to speaker 1	On: Enabled (Binaural) Off: Disabled (Monaural)	On
SW3-8	Listen 1 to left headphone	On: Enabled (Binaural) Off: Disabled (Monaural)	On

IMPORTANT: Set all to monaural or all to binaural. Do not mix settings.

Headset Microphone Type Selection Dip Switch

SW1-1 applies only to a dynamic-mic headset connected to the dynamic-mic headset jack on the front panel. If the headset specifications indicate the microphone type is balanced, or if you are unsure, leave this switch in the OFF (default) position. If the specifications indicate an unbalanced microphone set SW1-1 to ON.

NOTE: For best results in noisy environments, a noise canceling (directional or cardioid) microphone is highly recommended. This is especially true if you are using the vox feature.

Mic Kill Send Enable DIP Switch

The US2002 can generate an inaudible signal which will turn OFF the microphones on all intercom stations on a channel (for stations that detect this signal). This feature is useful, for example, when an unattended microphone has been left ON and is causing unnecessary noise on a channel. By default, Mic Kill is not enabled. To activate this feature, set SW1-6 to the ON position.

Program Interrupt DIP Switches

If you plan on using external program sources with the US2002, you have a choice of whether or not you want the program audio to shut OFF on the intercom channel while you are talking. By default, program audio does not interrupt during talk. You can change this as follows:

1. For channel 1 program interrupt during talk, set **SW1-7** to ON.
2. For channel 2 program interrupt during talk, set **SW1-8** to ON

If call signal receive is enabled (switches SW1-3 and SW1-5), incoming calls will be indicated by red-flashing Call keys. An optional beep tone can also be used. Internal switches enable the beep tone. You can then turn the beep tone ON or OFF via the front panel during normal operation. Enable the beep tone as follows:

1. Make sure the call signal receive DIP switches are ON (SW1-3 and SW1-5).
2. For incoming call beep in a headset, set **SW3-1** to OFF.
3. For incoming call beep in speaker 1, set **SW3-1** to OFF and **SW3-3** to ON.
4. For incoming call beep in speaker 2, set **SW3-1** to OFF and **SW3-4** to ON.
5. The procedure to turn incoming call beep ON or OFF during operation can be found on page 29.

Monaural or Binaural Operation DIP Switches

The US2002 can be used with a single speaker or monaural headphones (single- or double-sided) for monaural operation. In this case, all audio signals are combined and sent to the headphones and the Speaker 1 jack on the back panel. The US2002 can also be used with two speakers for binaural operation. In this case, channel 1 is sent to the Speaker 1 jack and channel 2 is sent to the Speaker 2 jack. Binaural headphone operation is not supported.

For Monaural operation with headphones or one speaker (factory default):

1. Set SW3-2 to **OFF**.
2. Set SW3-5 to **ON**.
3. Set SW3-6 to **OFF**.
4. Set SW3-7 to **ON**.
5. Set SW3-8 to **ON**.

For binaural operation with 2 speakers:

1. Set SW3-2 to **ON**.
2. Set SW3-5 to **OFF**.
3. Set SW3-6 to **ON**.
4. Set SW3-7 to **OFF**.
5. Set SW3-8 to **OFF**.

Balanced / Unbalanced Switch (SW2)

This switch is set at the factory to the balanced (BAL) position for use with Audiocom intercom channels. Set the switch to the unbalanced (UNBAL) position for use with Clear-Com intercom systems.

Direct Program Listen Enable / Disable Jumpers

By default, each US2002 program input can be heard by all intercom stations that are listening on the corresponding intercom channel. This includes the US2002. Program input routing to the intercom channels can be turned ON or OFF via the US2002 front panel programming. (See “External Program Input and PA Output” on page 11.) Additionally, all program signals can be routed directly to the US2002 speaker or headset. This lets the US2002 operator hear the program inputs even if they are not being routed to the intercom channels. To disable direct program listening in the speaker or headset for one or more program inputs, reset the appropriate jumper as shown in Table 2 .

Jumper	Description	Setting for Jumpers
J3	Program 1 direct to Headset or Speaker	Pins 2 & 3 shorted: Enabled Pins 1 & 2 shorted: Disabled
J6	Program 2 direct to Headset or Speaker	

TABLE 2. Direct Program Listen Enable/Disable Jumpers

Mounting Configurations

The US2002 can be used on a desktop, or it can be rack mounted. For desktop use, install the 4 rubber feet supplied with the US2002. For rack mounting, use optional Audiocom RMK Rack Mount Kits (Figure 3).

NOTE: You will have to perform the sidetone adjustment (See “Sidetone Adjustment” on page 25.) after all components are connected. However when the US2002 is rack mounted, you may not be able to access the sidetone trimmers. In this case, you can position the US2002 in the rack and make all required connections. Then, adjust the sidetone trimmers before installing and tightening all rack mount screws.

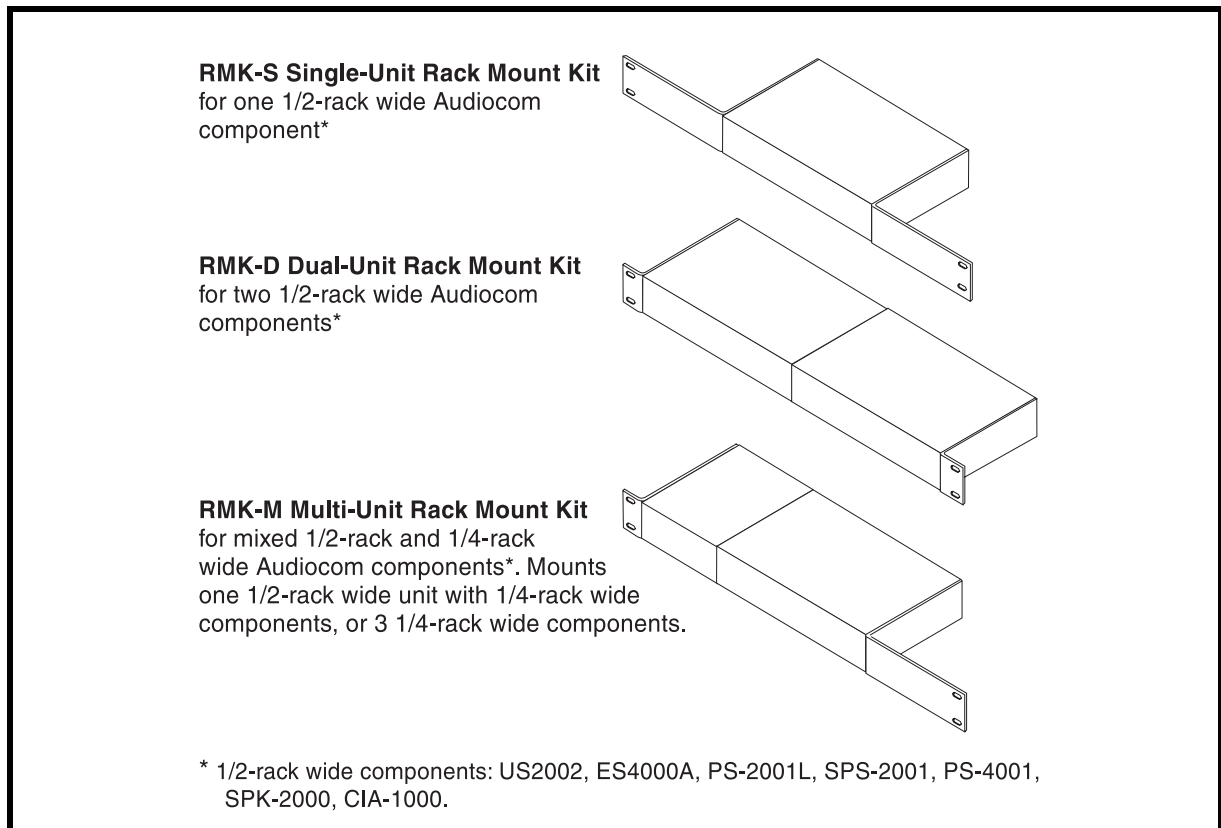

FIGURE 3. Audiocom RMK Rack Mount Kits

Connections

Central Master Station vs. Remote Station

The US2002 can be used in a variety of configurations as a speaker station or as a headset station. Additionally, it can be used as a central master station or as a remote station. When used as a central master station, the US2002 is placed in the same location as the system power supplies, and if an SPS2001 power supply is used, the US2002 can take advantage of the SPS2001 built-in speaker for speaker output. When used as a remote station, a separate speaker must be supplied. Figures 4 through 12, starting on page 13, illustrate several configurations for the US2002 when used as a central or remote headset or speaker station.

All Locally Powered Stations

Any US2002 can be locally powered by connecting a PS-KP Local Power Supply. This is shown as an option in Figures 4 through 12. A special case is an intercom system where all stations are powered from local power supplies, with no central power supply. This is illustrated in Figure 13 on page 22.

External Program Input and PA Output

Connections for external program input and PA output are show in Figure 14 on page 23.

ES4000A Expansion Station Connection (Optional Component)

Refer to the ES4000A User Instruction Manual for detailed connection information.

Cables

The numbers below correspond to the cable number in the connection drawings on the following pages.

1. 1-channel intercom cable. Sold separately. Use Telex “ME” cables, below. Or, build per Figure 15 on page 24.

ME-25: 25' (7.6 m) cable with Male and Female 3-pin XLR connectors.

ME-50: 50' (15.2 m) cable with Male and Female 3-pin XLR connectors.

ME-100: 100' (30.4 m) cable with Male and Female 3-pin XLR connectors.

**When connecting from a power supply to a TW-7W, keep cables as short as possible. Also, heavier gage wire is recommended.

2. 2-channel intercom cable. Sold separately. Use Telex “ME/2” cables, below. Or, build per Figure 15 on page 24.

ME-25: 25' (7.6 m) cable with Male and Female 6-pin XLR connectors.

ME-50: 50' (15.2 m) cable with Male and Female 6-pin XLR connectors.

ME-100: 100' (30.4 m) cable with Male and Female 6-pin XLR connectors.

3. Y adapter cable. Sold separately. Use Telex CA-23-16. Or, build per Figure Figure 15 on page 24.
4. 3ft. (0.91m) speaker cable with RCA plugs. One supplied with each SPS-2001 SPK-2000.
5. 18” (457 mm) EXP IN/OUT cable, stereo miniplug to stereo miniplug. One supplied with each ES4000A.
6. 18” (457 mm) CHANNEL OUTPUT cable, 15-pin Male Dsub to 15-pin Male Dsub. One supplied with each ES4000A. (Optional component. See ES4000A User Manual for connection information.)
7. Shielded patch cable, 9-pin Male Dsub to 9-pin Female Dsub. Customer local purchase: available at most electronic stores.

NOTE: All pins must be connected straight through: do not use a RS232 computer cable.

8. Shielded patch cable, stereo miniplug to stereo miniplug. Customer local purchase: available at most electronic stores.
9. Shielded audio cable. Must have male 3-pin XLR connector at one end for connection to the XP-USPG or XP-4PGM program inputs. Pin-out for program inputs is as follows:
 - Pin 1: common
 - Pin 2: + program input
 - Pin 3: - program input

10. Shielded audio cable. Must have male 3-pin XLR connector at one end for connection to the XP-USPG PA output. Pin-out for PA output is as follows:
 - Pin 1: common
 - Pin 2: + PA output
 - Pin 3: - PA output

11. 18" (457 mm) CHANNEL OUTPUT cable, 15-pin Male Dsub to 15-pin Female Dsub. One supplied with each XP-ES4000. (Optional component. See ES4000A User Manual for connection information.)

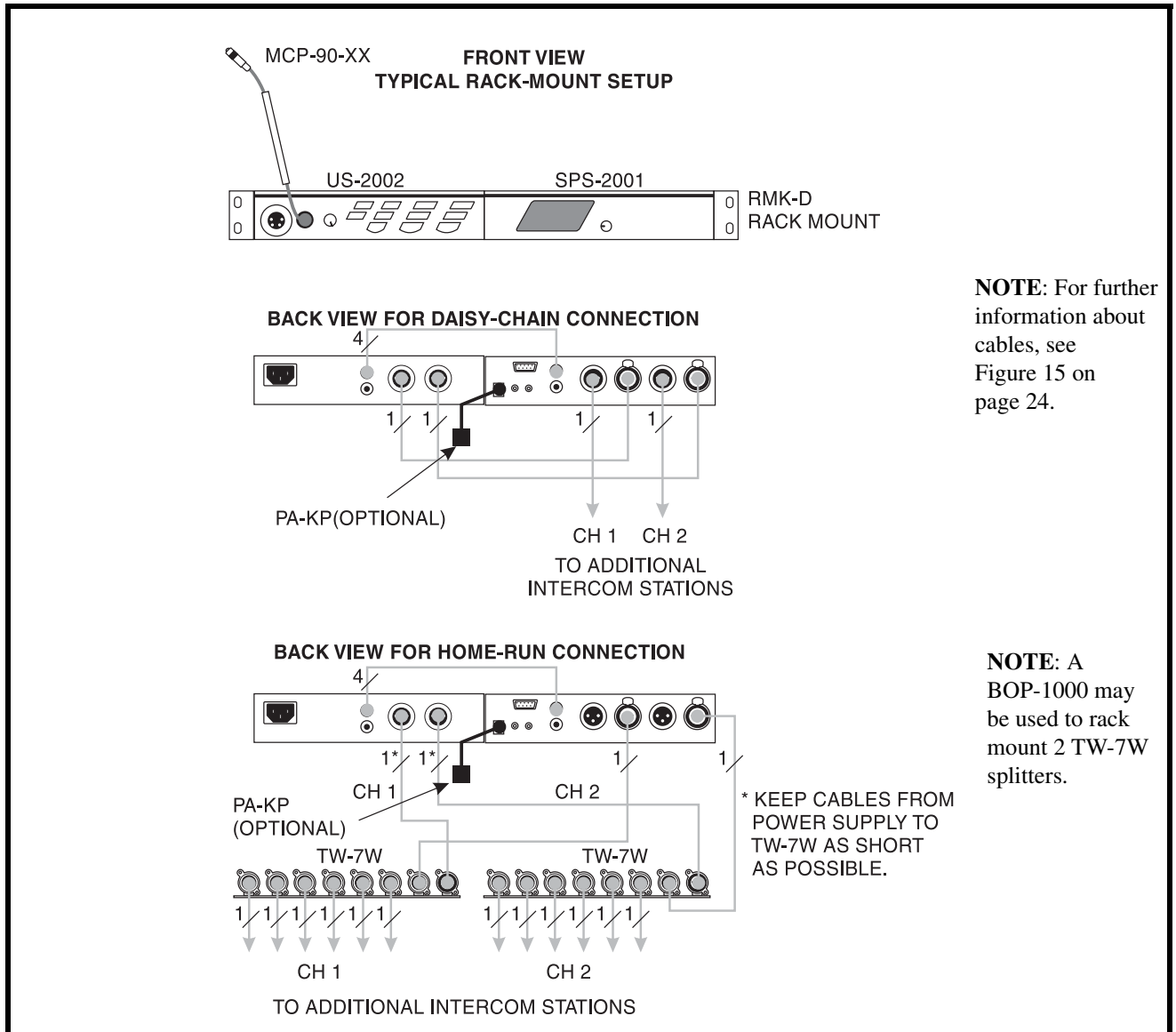

FIGURE 4. US2002 Monaural Master Speaker Station Configuration with 1 Power Supply. This is a good configuration for a smaller intercom system when you want to operate the US2002 as a master speaker station, with one speaker to monitor both intercom channels. In this configuration, the SPS-2001 Combine/Isolate switch is set to the Isolate position. With this setting, the 2 intercom channels are completely separated. The amplified speaker in the SPS2001 is used as the speaker output for the US2002, and the US2002 dip switches are set to monaural operation so that both intercom channels are heard in the speaker. The PA-KP local power supply is optional. When a PA-KP is connected, the US2002 automatically disconnects from system power (supplied by the SPS2001). When the US2002 is not drawing power from the intercom system, more system power is available for additional belt packs, etc.

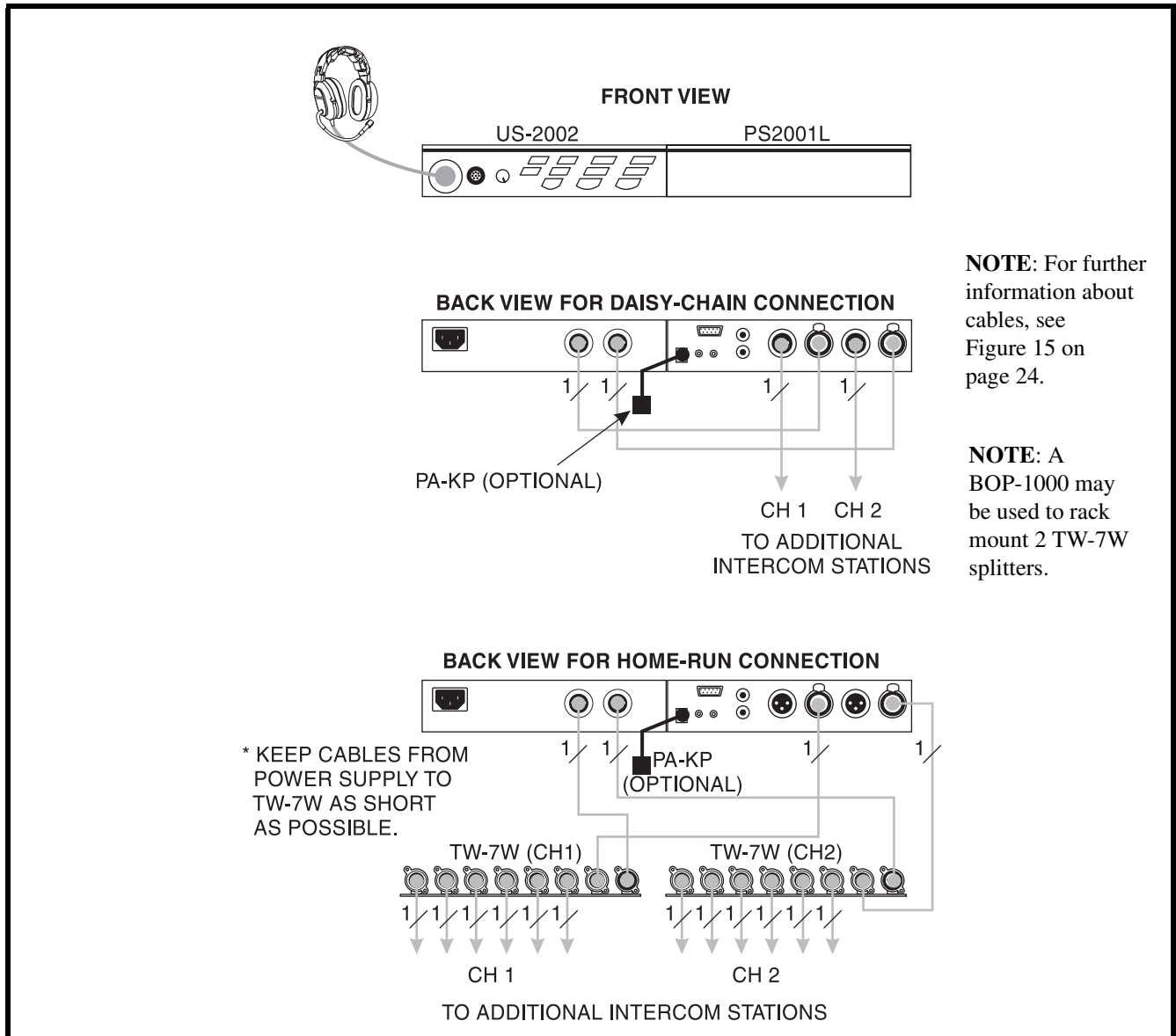

FIGURE 6. US2002 Master Headset Station Configuration with 1 Power Supply. This is a good configuration for smaller intercom systems when you want to operate the US2002 as a master headset station. In this configuration, the PS2001L Combine/Isolate switch is set to the Isolate position. With this setting, the 2 intercom channels are completely separated. Typically, a headset is connected to the front panel of the US2002, and the US2002 DIP switches are set to monaural operation (default setting), so both intercom channels are heard in the monaural headphones (binaural headphone operation is not supported). The PA-KP local power supply is optional. When a PA-KP is connected, the US2002 automatically disconnects from system power that is supplied by the PS2001L. Since the US2002 is not drawing power from the intercom system, more system power is available for additional belt packs, etc.

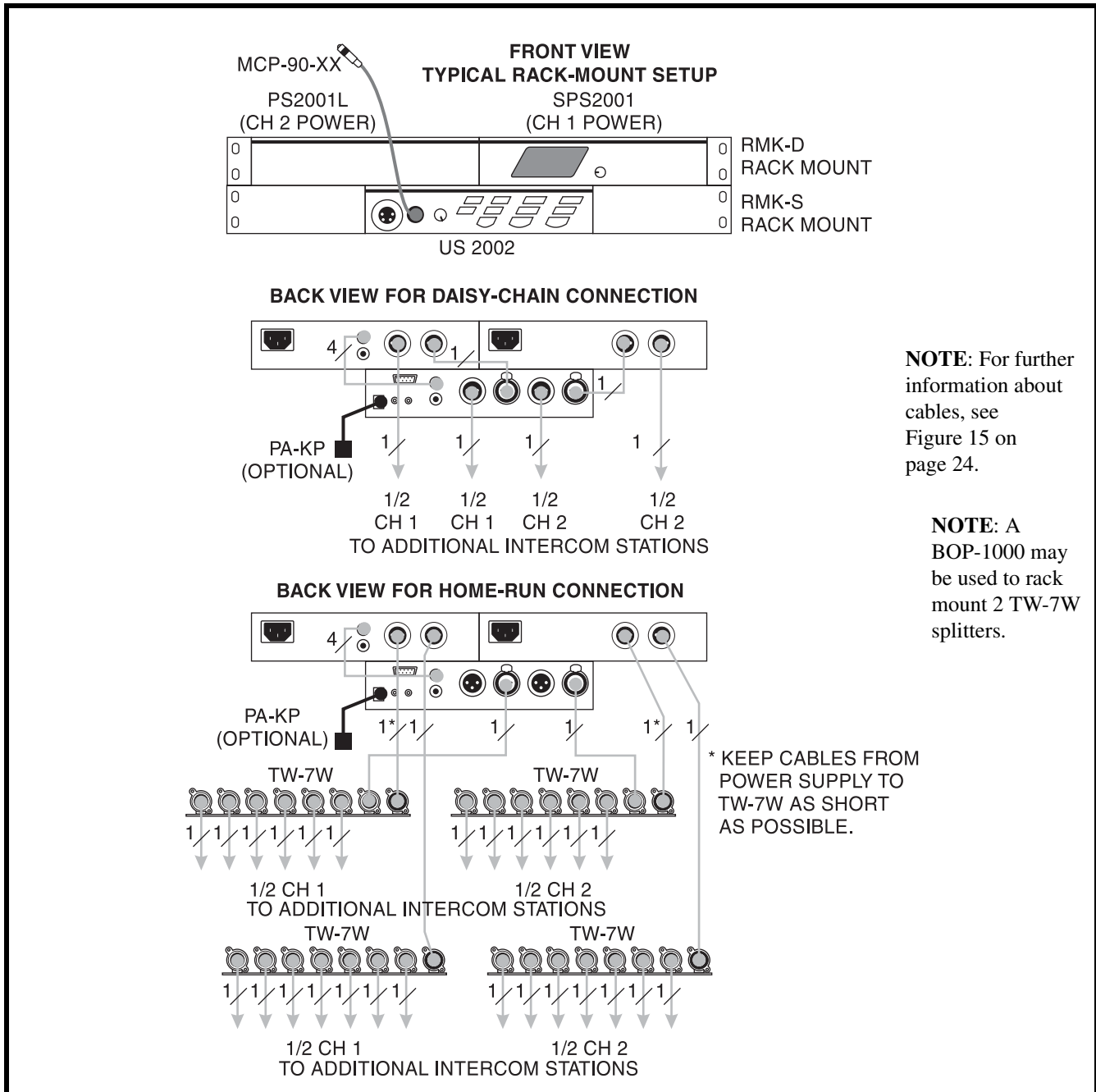

FIGURE 7. US2002 Monaural Master Speaker Station Configuration with 2 Power Supplies. This is a good configuration for large intercom systems when you want to operate the US2002 as a master speaker station, with one speaker to monitor both intercom channels. In this configuration, the SPS2001 and PS2001L Combine/Isolate switches are set to the Combine position. With this setting, all intercom stations connected to the SPS2001 are combined on intercom channel 1 and all intercom stations connected to the PS2001L are combined on channel 2. The amplified speaker in the SPS2001 is used as the speaker output for the US2002 and the US2002 dip switches are set for monaural operation (default setting) so that both intercom channels are heard in the speaker. The PA-KP local power supply is optional. When a PA-KP is connected, the US2002 automatically disconnects from system power. Since the US2002 is not drawing power from the intercom system, more system power is available for additional belt packs, etc.

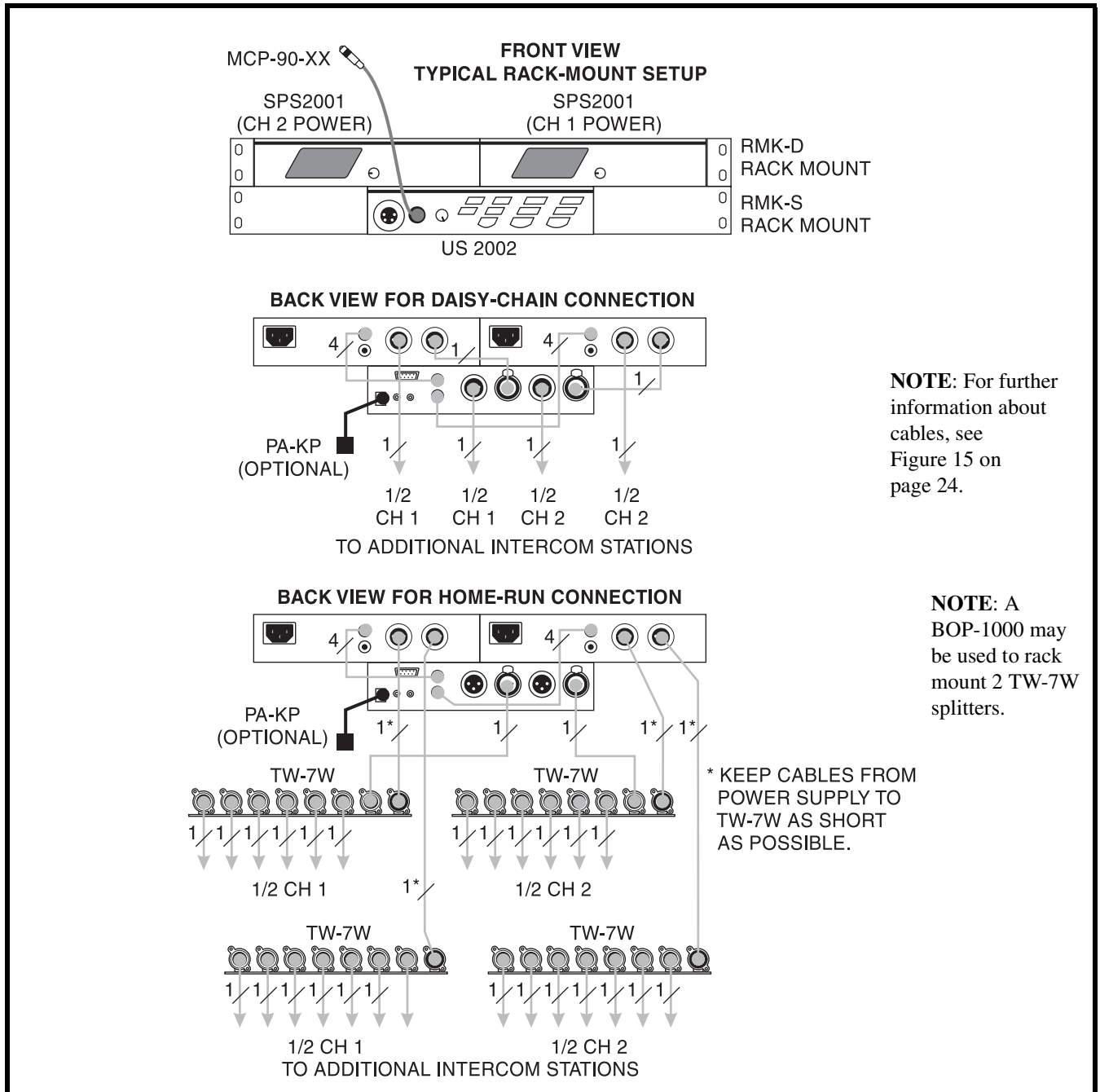

FIGURE 8. US2002 Binaural Speaker Station Configuration with 2 Power Supplies. This is a good configuration for large intercom system when you want to operate the US2002 as a master speaker station, with a separate speaker for each intercom channel. In this configuration, the SPS2001 Combine / Isolate switches are set to the Combine position. With this setting, all intercom stations connected to the one SPS2001 are combined on intercom channel 1 and all intercom stations connected to the other SPS2001 are combined on channel 2. The amplified speaker in each SPS2001 monitors a single intercom channel, and the US2002 dip switches are set to binaural operation (see page 9.) The PA-KP local power supply is optional. When a PA-KP is connected, the US2002 automatically disconnects from system power. Since the US2002 is not drawing power from the intercom system, more system power is available for additional belt packs, etc.

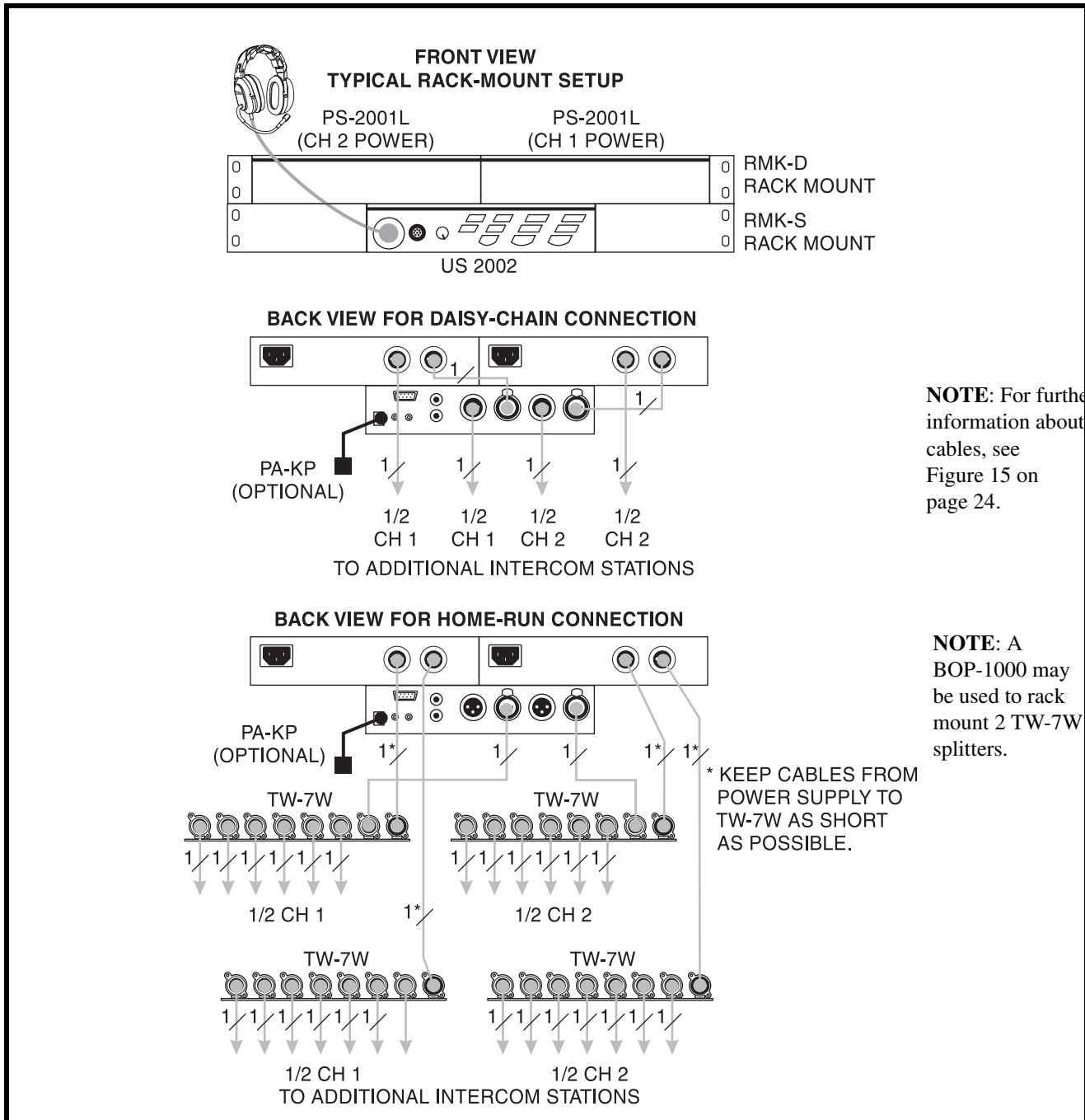

FIGURE 9. US2002 Headset Station Configuration with 2 Power Supplies. In this configuration, the PS2001L Combine/Isolate switches are set to the Combine position. With this setting all intercom stations connected to the one PS2001L are combined on intercom channel 1 and all intercom stations connected to the other PS2001L are combined on channel 2. Typically, a headset is connected to the front panel of the US2002, and the US2002 dip switches are set to monaural operation (default setting) so that both intercom channels are heard in the monaural headphones (binaural headphone operation is not supported). The PA-KP local power supply is optional. When a PA-KP is connected, the US2002 automatically disconnects from system power. Since the US2002 is not drawing power from the intercom system, more system power is available for additional belt packs, etc.

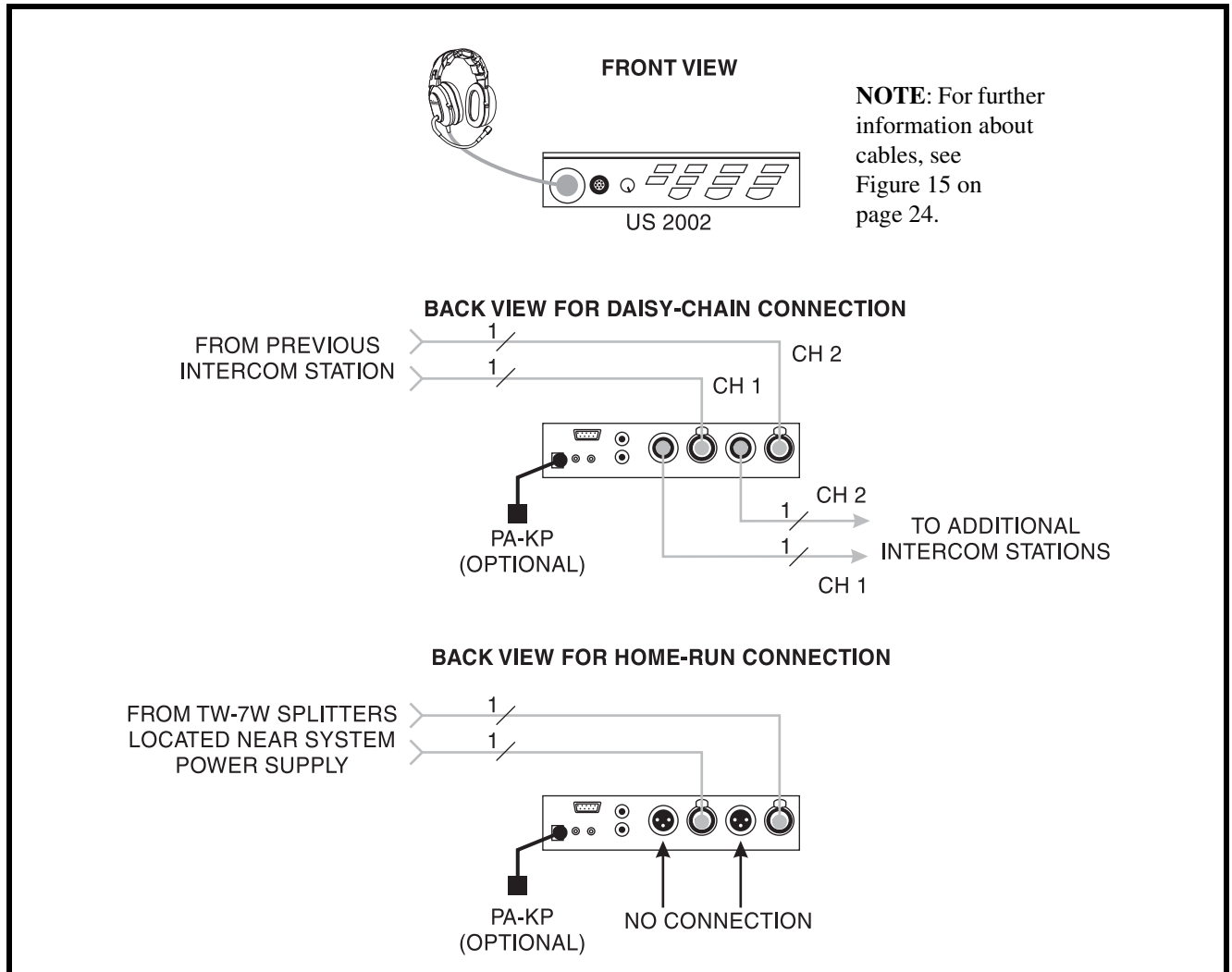

FIGURE 10. Typical Remote Headset Station. In this example, the US2002 is not located near the system power supplies (SPS2001, PS2001L, etc.). The PA-KP local power supply is optional and can be used to power a single intercom station. When a PA-KP is connected to the US2002, the US2002 automatically disconnects from system power. This makes more system power available for belt packs and other intercom stations. Also, when the US2002 is powered by a PA-KP, it can be operated over a greater distance as a remote station.

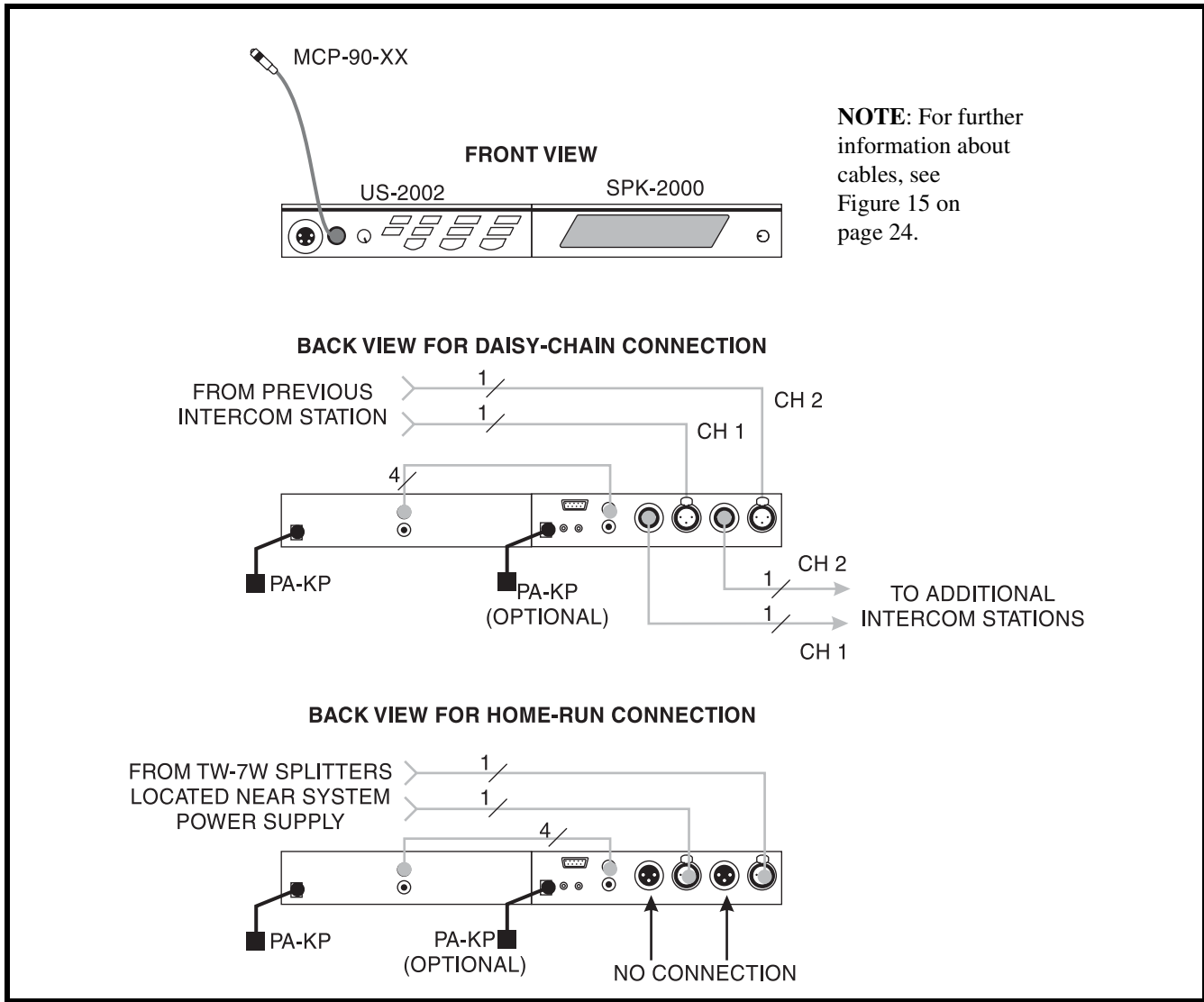

FIGURE 11. Typical Remote Monaural Speaker Station. This example is similar to the one on the previous page, except a Telex MCP-90-XX microphone and a SPK-2000 speaker are used instead of a headset. Make sure the intercom DIP switches are set for monaural speaker operation (default setting) as described on page 9. A PA-KP local power supply is required for the SPK-2000, but is optional for the US2002. When a PA-KP is connected to the US2002, the US2002 automatically disconnects from system power. This makes more system power available for belt packs and other intercom stations. Also, when the US2002 is powered by a PA-KP, it can be operated over a greater distance as a remote station.

NOTE: For further information about cables, see Figure 15 on page 24.

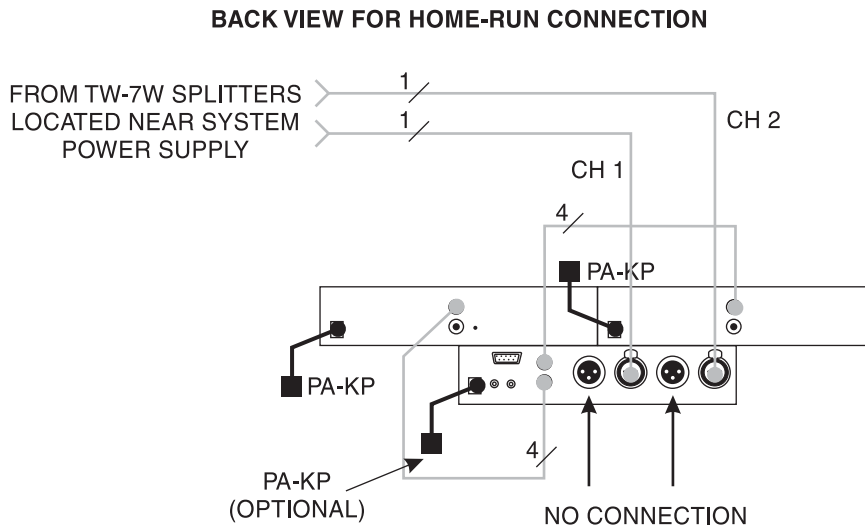
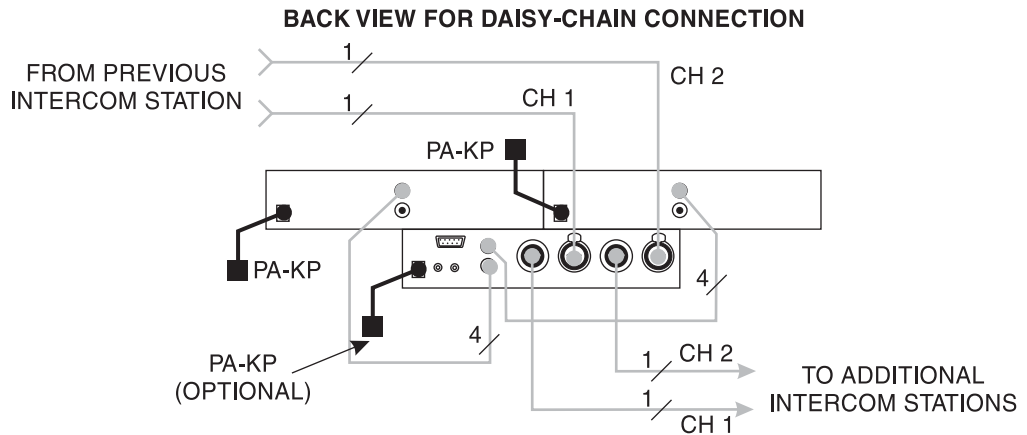
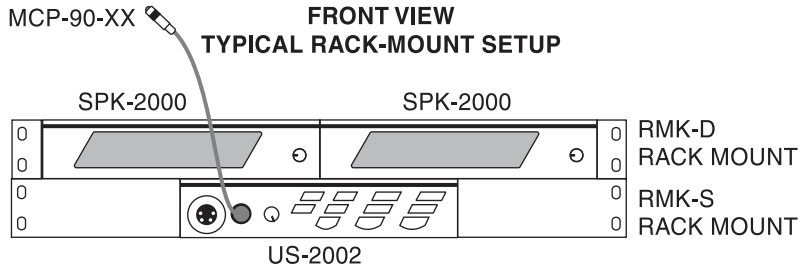
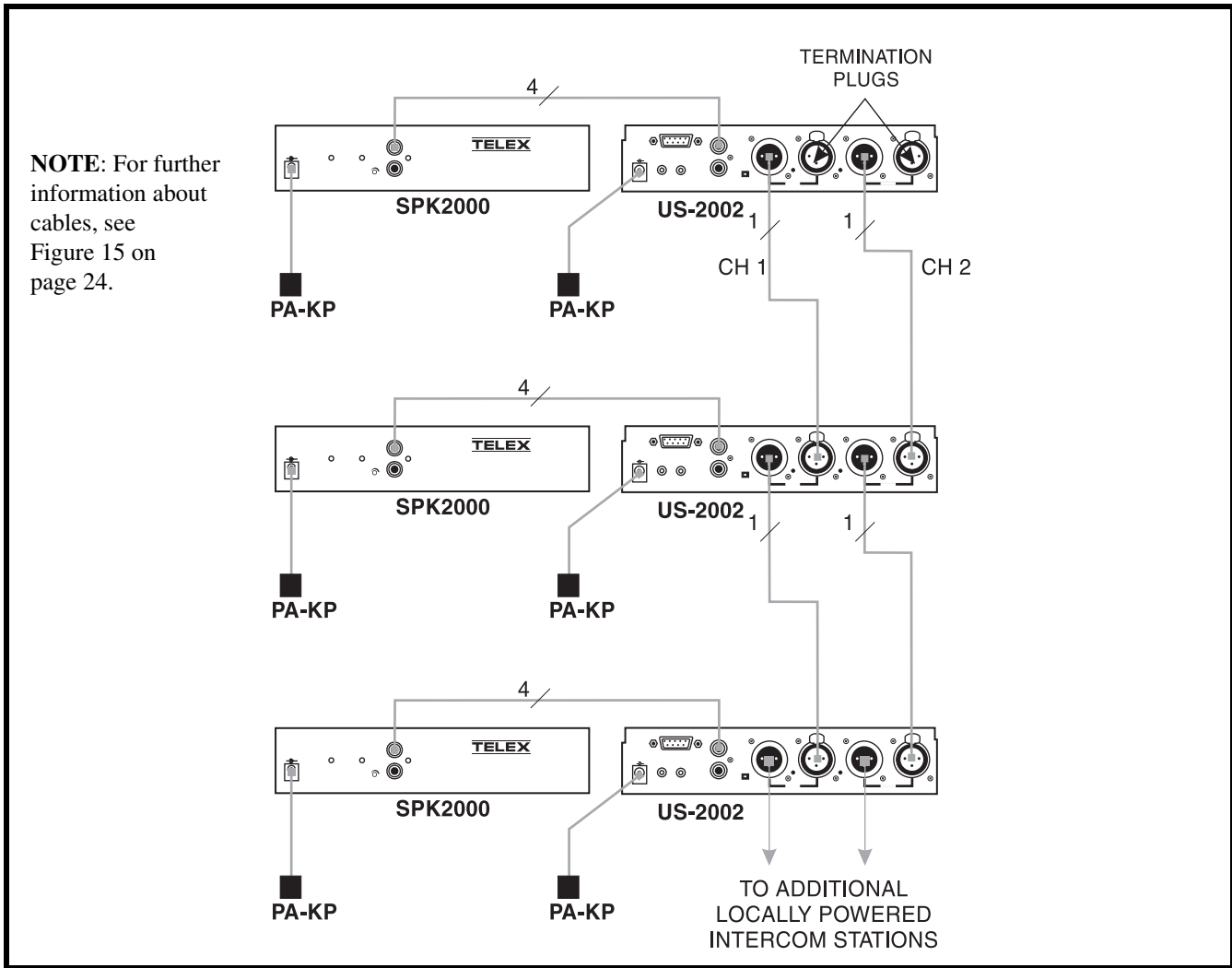

FIGURE 12. Typical Remote Binaural Speaker Station. This example is similar to the one on the previous page, except that each channel is heard in a separate speaker. Make sure the internal DIP switches are set for binaural speaker operation as described on page 9. As in the previous example, a PA-KP local power supply is required for each SPK2000 speaker, but is optional for the US2002.



NOTE: For further information about cables, see Figure 15 on page 24.

FIGURE 13. An example of all locally powered US2002 intercom stations. In this example, all components are locally powered using PA-KP local power supplies. Note, the use of one termination plug in each intercom channel. (One termination plug is supplied with each US2002.) Only one termination plug should be installed per channel. Typically, they are installed at the first intercom station in the chain. If 2 terminations are installed in a channel, the sound quality and volume level will be noticeably reduced. **IMPORTANT!** If a system power supply (SPS2001, PS2001L, etc.) is ever connected anywhere in a channel, the termination plug should be removed from that channel, because the system power supply already has a built-in termination. The advantage of locally powered stations is that they can be operated over a greater distance than is possible when using a system power supply.

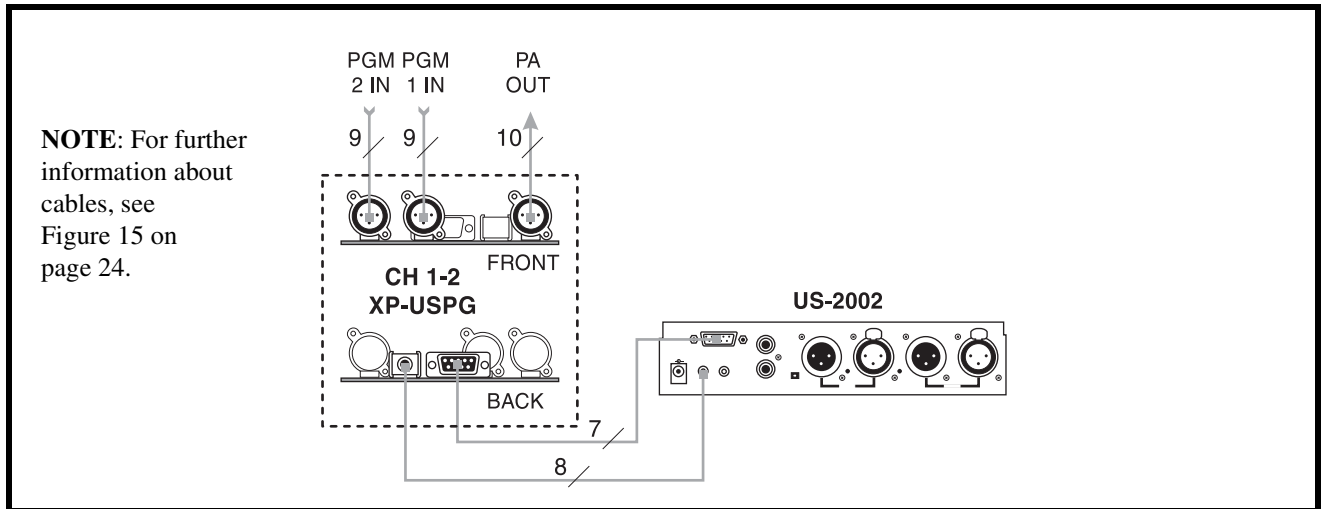
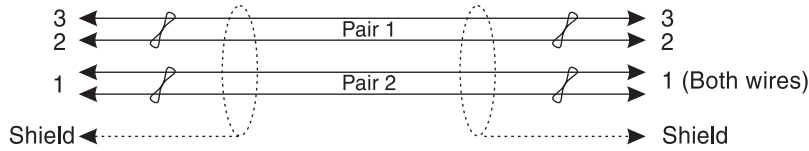

FIGURE 14. External Audio Input and PA Output. You can connect two audio sources to the Program Inputs connector: one for each channel. Audio sources can be directly connected with a user-supplied DB9M connector. (Refer to the program input connector specifications, located on page 11, for connector pin-out.) However, a more convenient method is to use an XP-USPG Breakout Panel as shown. The XP-USPG lets you use standard, 3-pin XLR audio cables to connect audio sources. The XP-USPG also interfaces the PA jack of the US2002 to a standard, 3-pin XLR audio cable. **Note:** The XP-USPG Breakout Panel can be rack mounted using a BOP-1000 Rack Mount Plate.

TYPICAL 1-CHANNEL CABLE WIRING



Cable Type: 22AWG Stranded, 2-Pair Twisted-wire, with Shield

Connector Type: 3-Pin XLR Audio (Neutrik or Switchcraft)*

Pin 1: Common

Pin 2: Channel Audio / Power

Pin 3: Channel Audio / Power

Shield: Earth ground

Denotes twisted pair.

Denotes shield.

TYPICAL 2-CHANNEL CABLE WIRING

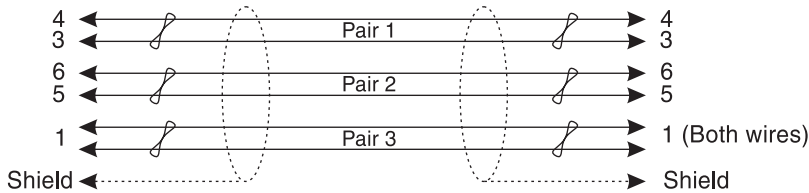

Cable Type: 22AWG Stranded, 3-Pair Twisted-wire, with Shield

Connector Type: 6-Pin XLR Audio (Neutrik only, not compatible with 6-pin Switchcraft)*

Pin 1: Channel 1 & 2 Common

Pin 2: No connection

Pin 3: Channel 1 Audio / Power

Pin 4: Channel 1 Audio / Power

Pin 5: Channel 2 Audio / Power

Pin 6: Channel 2 Audio / Power

Shield: Earth ground

Denotes twisted pair.

Denotes shield.

“Y” CABLE WIRING

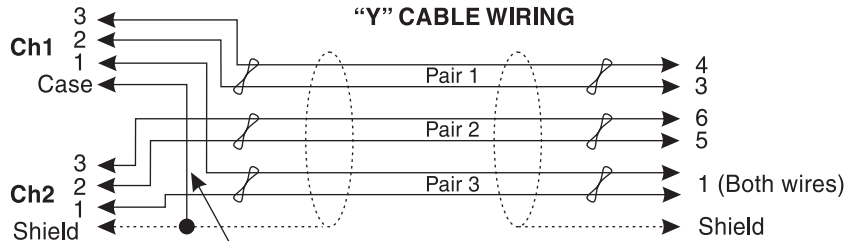

Use second drain wire if available, or add an extra section of wire.

* Standard cables are generally constructed using a male connector at one end and a female connector at the other end. This allows several cables to be interconnected to create longer cable runs. Audiocom master stations, speaker stations and belt packs also typically provide both a male and female Neutrik connector for each intercom channel. This permits loop-through connection of several intercom stations using the standard cables. Audiocom power supplies use a 3-pin male Neutrik connector for each channel. Audiocom wallplates use male Neutrik connectors.

FIGURE 15. Audiocom Intercom Cables

Power-Up Check

Plug in any PA-KP local power supplies that are being used, and also turn on any system power supplies that are being used. When power is first applied to the US2002, it will perform a power-up reset, in which the front panel indicators will cycle through all of their possible colors and then turn OFF. This verifies the general operation of the intercom station and indicators. The US2002 also reads the settings of all DIP switches at this time and configures itself accordingly.

Test Tone

The US2002 can generate a test tone, which can be used to verify intercom channel operation after installation or to locate a malfunction. This test tone is also used for the sidetone adjustment which follows.

Use the test tone as follows:

1. Simultaneously press the **All Talk** and **PA** keys to activate the test tone.
2. Tap the **Call** key for the channel that you want to test (can be either US2002 channel or an ES4000A channel).
3. Verify the **test tone** can be heard at all intercom stations on the channel. Replace any defective cables or intercom stations where the test tone is being lost.
4. Tap the same **Call** key to stop the test signal on that channel.
5. Press **any key** except a Call key to turn OFF the test tone.

Sidetone Adjustment

The US2002 uses full-duplex audio (the same as a conventional telephone line) in which the talk and listen audio are sent and received on the same line. Thus, when you talk on a channel, you will also hear your own voice back in the speaker or headphones. This is called **sidetone**. If you are using the US2002 with a microphone and speaker, sidetone could cause unwanted feedback, since the microphone may pick up your returned voice audio and re-amplify it. This could also happen if you are using a headset where the ear cushions do not completely cover the ears, although it is probably much less likely. In either of the cases, you should minimize the amount of sidetone. On the other hand, if you are using headphone that completely enclose the ears, a certain amount of your own voice level is desirable to overcome the muffled sensation when talking.

If you are using a speaker and microphone, or open-ear style headphones, adjust sidetone as follows:

1. Simultaneously press the **ALL Talk** and **PA** keys to activate the test tone.
2. Tap the **channel 1 Call key** to send the test tone on channel 1.
3. Increase the **volume** until you can hear the test tone. (If you are using a headset, adjust the volume control at the US2002. If you are using a speaker, adjust the volume control at the speaker.)
4. Using a small flat-bladed screwdriver, **adjust the channel 1 sidetone** through the access hole in the bottom of the US2002 (Figure 16) to minimize the tone volume.
5. Tap the **channel 1 Call key** to turn OFF the test tone on channel 1 when finished.
6. Tap the **channel 2 Call key**, and repeat the adjustment for the channel 2 sidetone.
7. Tap any **other key**, except a Call key, to turn OFF the test tone when finished.

If you are using headphones that completely enclose the ears, adjust sidetone as follows:

1. Tap the **Headset key** to turn the headset microphone ON.
2. Tap the **channel 1 Talk key** to turn it ON.
3. While speaking into the microphone, use a small flat-bladed screwdriver to **adjust the channel 1 sidetone** so that you hear your voice at an acceptable level in the headphones.
4. Tap the **channel 1 Talk key** to turn it OFF when finished.
5. Tap the **channel 2 Talk key** to turn it ON, and adjust the channel 2 sidetone as for channel 1.
6. Tap the **channel 2 Talk key** to turn it OFF when finished.

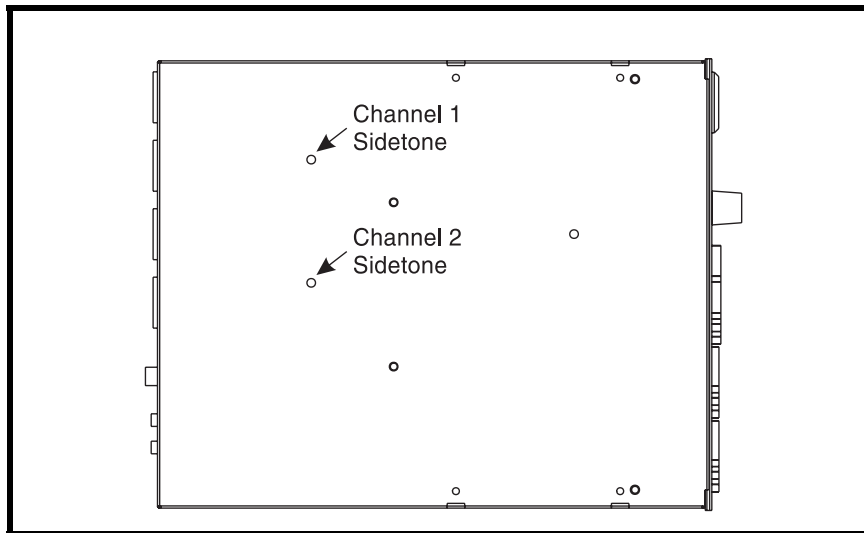

FIGURE 16. US2002 Bottom View

Voice-Activated Microphone (Vox) Setup

If you are going to use vox, you must adjust the vox level for proper operation. If the vox level is too low, room noise will activate the microphone. If the vox level is too high, the microphone will not activate when you begin talking. Check and set the level as follows:

1. If you are using a headset, tap the Headset key twice to turn ON headset vox. Or, if you are using a panel microphone, tap the Panel Mic key twice to turn ON the panel mic vox. Whichever key you tap, it will glow orange when the microphone is OFF and will flicker or turn green when sound is picked up by the microphone.
2. Position the microphone at its normal operating location. If you are using a headset, put the headset on and position the microphone close to your mouth. Insure that background noise is at the normal operating level.
3. Do not speak into the microphone.
4. Check the Headset or Panel Mic key, whichever you are using. If the key is constantly glowing orange, turn the vox trimmer clockwise until the key begins to flicker green (mic activating) then turn the trimmer slightly back in the counter-clockwise direction until the Panel Mic key just returns to steady orange (mic off). If you are wearing a headset, make sure that breathing and movement do not cause the Panel Mic key to flicker green. If they do, adjust the vox control slightly more in the counter-clockwise direction to eliminate this.
5. Speak into the microphone in a normal voice, and check that the headset key immediately turns green when you talk. If it does not, move the microphone closer to your mouth. If you are still unable to get satisfactory results, it may be that the microphone does not have the directional characteristics required for the noise level in the room. A directional, or carotid, microphone is recommended when using vox. Omnidirectional microphones may not produce good results.

Operation

NOTE: A quick-reference to the following operating features can be found on the inside of the back cover.

Normal vs. Programming Mode

The US2002 has two operating modes: **normal operating mode** and **programming mode**. In normal operating mode, the Mic Kill key will be unlit, and in programming mode it will be lit continuously. To return the US2002 to normal operation if it has been left in programming mode, tap the Mic Kill key.

Volume Adjustment

If you are using a headset, adjust the intercom listen level with the Volume control on the front panel of the US2002. If you are using a speaker, adjust the intercom listen level with the Volume control on the speaker.

Receiving Calls

1. When there is an incoming call signal on a channel, the Call key for that channel will flash red. There will also be a beep tone if the beep feature has been activated (page 29).
2. Activate the microphone: If you are using a dynamic-mic headset tap the Headset key to turn the mic ON; if you are using a panel-mounted microphone or an electret-mic headset, tap the Panel Mic key to turn the mic ON.

NOTE: You can also use the voice-activated microphone (Vox) feature (See page 29).

3. Turn on the Talk and Listen keys for the calling channel and begin your conversation.
4. Turn the keys OFF when finished.

NOTE: When you tap the Headset key, or the Panel Mic key, or an any Talk or Listen key, it will lock in the ON position. You may then tap the key again to turn it OFF. For momentary activation, press and hold the key. It will remain ON as long as you hold it and it will turn OFF when you release it.

Calling an Intercom Channel

1. Press and hold the **Call key** for the channel that you want to call
An inaudible call signal will be sent, and you listen key for that channel will automatically turn ON in preparation to receive a verbal response.
2. When you hear a response, release the **Call key**.
3. If you are using a manual microphone activation, make sure your microphone is **ON**: for a dynamic mic headset, tap the Headset key to turn it ON; for a panel-mounted microphone or electret headset, tap the Panel Mic key to turn it ON.
4. Turn ON the **Talk key** for the channel you called to begin your conversation.
5. Turn OFF your **Talk and Listen keys** to end the conversation.

Microphone Mute During Talk

You can mute the microphone while talking. Simply tap either the Headset key or the Panel Mic key, whichever is currently being used. Tap the key again to turn the microphone back ON. (If you are using Vox, tap the key twice to reactivate vox.)

All Talk

You can talk to all intercom stations that currently have their listens activated. This applies to both channels of the US2002 as well as all talk channels of any connected ES4000A Expansion Stations. Use All Talk as follows:

1. If you are using manual microphone activation, make sure the proper **microphone switch** is turned ON (either Headset or Panel Mic).
2. Press and hold the **All Talk key** while talking.
3. Release it when finished.

NOTE: To insure that the All Talk key is never accidentally left in the ON position, it does not latch.

Public Address (PA)

If the PA output on the back panel of the US2002 is connected to a public address system, you can talk on the public address system as follows:

1. If you are using manual microphone activation, make sure the proper microphone switch is turned ON (either Headset or Panel Mic).
2. Press and hold the PA key while talking.
3. Release it when finished.

To insure that the PA key is never accidentally left in the ON position, it does not have latching operation.

Turning the Program Inputs ON and OFF

1. Insure that program inputs have been connected at the back panel and that the program sources are ON.
2. Press and hold the **Mic Kill** key for about two seconds, then release it.
It should now be glowing green to indicate the US2002 is in programming mode.
3. The current status of the program inputs is indicated by the Talk keys. If the channel 1 Talk key is lit, the program 1 input is currently activated to channel 1; if channel 2 talk is lit, program 2 is activated to channel 2. Tap either **Talk** key to turn the program input for that channel ON or OFF.
4. When the program inputs are configured as desired, tap the **Mic Kill** key to exit programming mode and return to normal operation.
5. Adjust program **1** and **2** levels via the trimmers on the back panel of the US2002.

Using Mic Kill

If the Mic Kill feature has been enabled (page X) you can use it to deactivate all talk keys on a single channel or on all channels. This feature is useful when a remote talk key has been left ON and is causing unwanted noise on a channel.

Use Mic Kill as follows:

1. Tap the **Mic Kill** key.
It will blink green.
2. Tap the **Talk** or **Listen** key for a channel to turn OFF all talk keys on that channel. Or, tap the **All Talk** key to run OFF all talk keys.
The key you tap will turn green and the Mic Kill signal will be sent.
3. Tap **Mic Kill** to exit.

Using Voice-Activated Microphone (Vox)

If you use Vox, you will not have to insure that the microphone key is turned ON whenever you want to talk.

Activate Vox as follows:

1. Make sure the **Headset** and **Panel Mic** keys are OFF.
2. If you are using a headset, tap the **Headset** key twice to turn ON headset vox. Or, if you are using a panel microphone, tap the **Panel Mic** key twice to turn ON panel mic vox.
Whichever key you tap, it will glow orange when the microphone is OFF and will flicker or turn green when the microphone turns ON.

NOTE: The Vox level may require adjustment, see Figure , “Voice-Activated Microphone (Vox) Setup,” on page 27.

Incoming Call Beep On/Off

Normally, incoming calls are indicated by red-flashing Call keys. An optional beep tone can also be enabled, as follows:

1. Ensure this feature has been activated via internal switches (page 29.)
2. Press and hold the **Mic Kill** key for about two seconds, then release it.
It should now be glowing green to indicate the intercom station is in programming mode.
3. Tap either **Call** key on the US2002 to turn the beep feature ON or OFF. (It doesn't matter which one you tap, since this feature affects both channels.)
4. Tap the **Mic Kill** key to return to normal operation.

Specifications

General

Power Requirements:

Phantom Power: 24VDC nominal (12 to 30 VDC), 65 to 150 mA

Local Power: 12 to 15 VDC, 65 to 150 mA

Dimensions:

1.75" (44.5 mm) high x 8.25" (209.5 mm) wide x 10.31" 261.9 mm deep

Weight:

Approximately 2lb. (0.9 kg)

Environmental Requirements:

Storage: -20°C to 80°C; 0% to 95% humidity, non-condensing

Operating: -15°C to 60°C; 0% to 95% humidity, non-condensing

Dynamic-mic Headset

Microphone:

50 to 200 ohm, dynamic (balanced or unbalanced)

Headphones:

150 to 600 ohm, monaural

Connector Type: XLR-4M

Pin 1 - Mic low

Pin 2 - Mic high

Pin 3 - Headphone low

Pin 4 - Headphone high

Panel Microphone or Electret-mic Headset

Microphone:

5k ohm, electret (-57dB)

Headphones:

150 to 600 ohm, monaural

Connector Type:

IKP12 (MCP-90 series, stereo plug connector)

Program Input

Input Level:

100mB maximum

Voltage Gain:

25 ±3dB

Output Level:

1.0 VRMS nominal, 2.3 VRMS maximum

Input Impedance:

75k ohm

Common Mode Rejection:

Greater than 50dB

Connector Type: DB9F

Pin 1 - Ground

Pin 2 - Program 1 input low

Pin 3 - Program 2 input low

Pin 4 - NC

Pin 5 - NC

Pin 6 - Program 1 input high

Pin 7 - Program 2 input high

Pin 8 - NC

Pin 9 - NC

Intercom Channels, Balanced Mode (SW2 set to BAL position)

Output Level:

1 VRMS nominal

Input Impedance:

300 ohms

Bridging Impedance:

greater than 10,000 ohms

Sidetone:

-40dB, 35dB adjustable range

Call Signaling:

Send: 20kHz ±300Hz, 0.5VRMS ±10%

Receive: 20kHz ±800Hz, 100mVRMS

Mic-Kill Frequency

Send: 24kHz ±100Hz, 0.5VRMS ±10%

Detect: 24kHz ±800Hz, 100mVRMS

Noise Contribution

less than -70dB

Common Mode Rejection Ratio:

greater than 50dB

Connector Type: one XLR-3M and XLR-3F pair, wired in parallel, for each channel.

Pin 1 - Common

Pin 2 - Intercom audio low and +24VDC input

Pin 3 - Intercom audio high and +24VDC input

Intercom Channel, Unbalanced Mode (SW2 set to UNBAL position)

Output Level

1VRMS ±10%

Input Impedance

150ohms

Bridging Impedance

greater than 10,000ohms

Call Signaling

Send: 11 ±3VDC

Receive: 4VDC minimum

Connector Type: one XLR-3M and XLR-3F pair, wired in parallel, for each channel.

Pin 1 - Common

Pin 2 - +24VDC input

Pin 3 - Intercom audio high

PA Output

Output Level

235mVRMS

Connector Type: 1/8-inch Stereo Phone Jack

Tip - PA output high

Ring - Not used

Sleeve - Common

Speaker Output

Output Level

0dB nominal (1.0 VRMS)

Output Impedance

1000ohms nominal

Specifications

Frequency Response:

200Hz to 8kHz +1/-3dB

Connector Type: RCA Phono Jack

Tip: Speaker output high
Sleeve: Common

Expansion Input/Output

Type: 2.0mm stereo phone jack

Tip: Talk output
Ring: Listen input
Sleeve Common

External Power

Type: 2.0mm power jack

Internal pin: positive (+)
External shell: negative (-)

Headphone Amplifier

Voltage Gain:

30 ±3dB

Maximum Output:

250 mW ±10% into 150ohms, 65mW ±10% into 600ohms

Frequency Response:

200Hz to 8kHz +1/-3dB

Incoming Call Beep Tone:

2kHz, at the headphones

Total Harmonic Distortion:

Less than 0.2% at 200mW

Sidetone

18 ±2dB, adjustable

Panel Microphone Amplifier

Voltage Gains:

Mic to CHN; 25 ±3dB, before limiting

Mic to Headphone; adjustable, 45dB ±10% maximum, into 150ohms

Mic to PA; 15 ±3dB, 235mVRMS ±10%

Frequency Response:

200Hz to 8kHz +1/-3dB

Total Harmonic Distortion:

Less than 0.2% at CHN output

VOX Range

-75 to -30dB, -60dB factory set

Notes

TABLE 3. Quick Reference

Reset US2002	Press All Talk and Listen 1
Reset ES4000A	Press All Talk and Listen 5
Test signal ON	Press All Talk and PA, then tap Call
Test signal OFF	Tap Call, then tap any other key
Mic latched ON	Tap Headset or Panel Mic (key is green)
Mic latched OFF	Tap Headset or Panel Mic
Mic momentary ON	Hold Headset or Panel Mic
Mic momentary OFF	Release Headset or Panel Mic
VOX mode ON	Tap twice: Headset or Panel Mic (key is orange)
VOX mode OFF	Tap Headset or Panel Mic
All Talk ON	Hold All Talk when Headset or Panel Mic is lit (All Talk key is green)
All Talk OFF	Release All Talk
Public Address	Hold PA when Headset or Panel Mic is lit (PA key is green)
Mic kill, one channel	Tap Mic Kill, then tap Talk or Listen (Mic Kill key will blink green, and the Talk and Listen keys are green. Tap Mic Kill to exit.)
Mic kill, all channels	Tap Mic Kill, then tap All Talk (Mic Kill key will blink green, and all Talk and Listen keys are green.) Tap Mic Kill to exit.
Program ON	Hold Mic Kill, then tap channel's Talk key (key is green). Tap Mic Kill to exit.
Program OFF	Hold Mic Kill, then tap channel's Talk key. Tap Mic Kill to exit
Audible call alert ON	Hold Mic Kill, then tap either Call (all Call keys are red). Tap Mic Kill to exit.
Audible call alert OFF	Hold Mic Kill, then tap either Call. Tap Mic Kill to exit
Turn Mic Kill key OFF	Tap Mic Kill
Talk latched ON	Tap Talk (key is green)
Talk latched OFF	Tap Talk.
Talk momentary ON	Hold Talk
Talk momentary OFF	Release Talk
Call Signal ON	Hold Call
Call signal OFF	Release Call
Receive Call Signal	(Call keys blink red)
Listen latched ON	Tap Listen (key is green)
Listen latched OFF	Tap Listen
Listen momentary ON	Hold Listen.

