

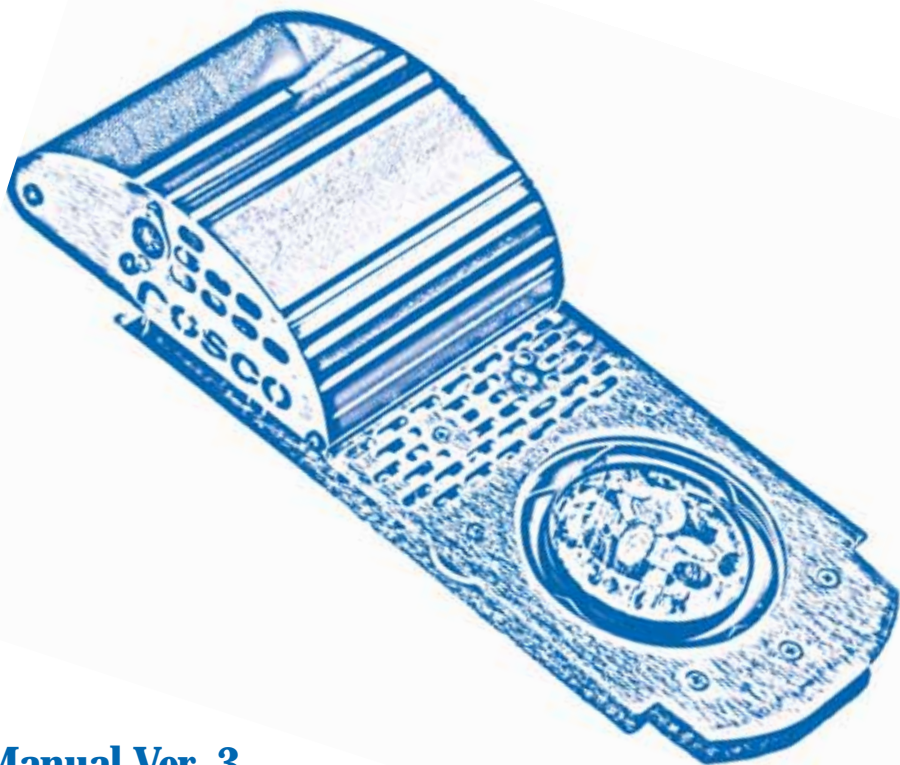

VORTEX 360™

**DUAL
ROTATOR**

**With
Variable Speed Control**



Manual Ver. 3

AN INTRODUCTION TO YOUR VORTEX

Thank you for your purchase of the Vortex 360. This product has been designed to provide you with reliable dual rotating gobo effects in your ETC Source 4 and Altman Shakespeare. It can accommodate both glass and metal size B gobos (86mm). Adjusting the speed and direction of the rotation is as simple as sliding a switch on the modular power adapter.

Parts and Functions

Below is a picture of the Vortex 360 and its power adapter with various components labeled.

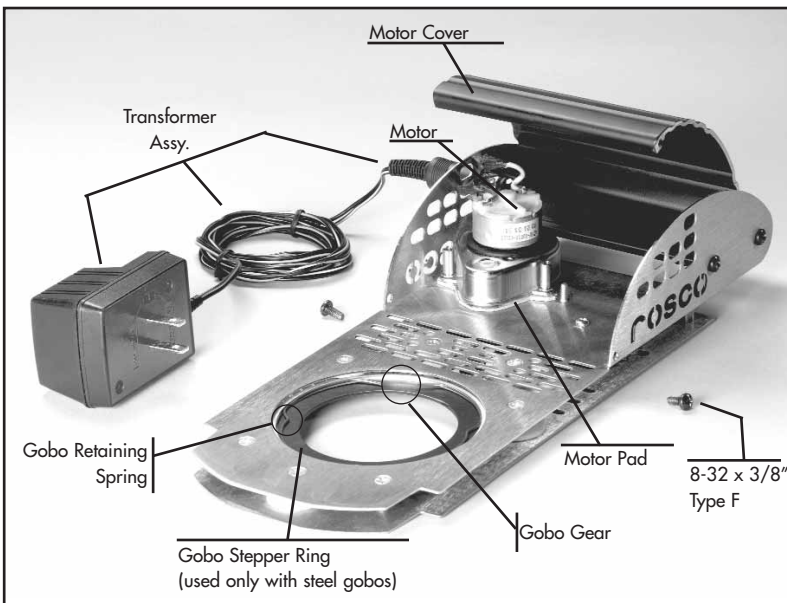

Vortex 360 rotator with power adapter (parts labeled)

INSTALLING GOBOS

Metal Gobos

- 1) Remove gobo retaining spring from gobo gear.
- 2) Remove steel gobo stepper ring from gobo gear.
- 3) Place metal gobo into gobo gear.
- 4) Replace steel gobo stepper ring in gobo gear.
- 5) Replace gobo retaining spring in gobo gear.



Metal gobo placed in Vortex 360.

Note: Avoid using bent or damaged metal gobos as they may result in jamming of the mechanism, which can lead to damage of the motor.

Glass Gobos

- 1) Remove gobo retaining spring from gobo gear.
- 2) Remove steel gobo stepper ring from gobo gear and put aside. It is not used with glass gobos.
- 3) Place glass gobo into gobo gear.
- 4) Replace gobo retaining plate in gobo gear.

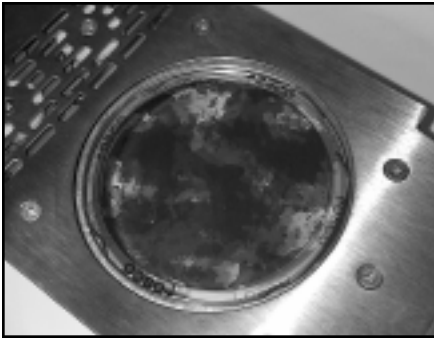

Glass gobo placed into Vortex 360.

INSTALLING THE VORTEX 360 IN THE FIXTURE

- 1) Decide whether you will be using 100-120VAC or 200-240VAC with the Vortex 360. Make the appropriate switch selection on the power adapter.
- 2) Open accessory slot (Iris Slot) on fixture.
- 3) Slide Vortex 360 into fixture's accessory slot with **motor covering facing toward the front of the fixture**. (This is important to avoid overheating the motor and to keep the shutters readily accessible.)
- 4) **Use safety cable** through handle of Vortex 360 to attach to fixed safety point.
- 5) Make sure power adapter cable is not touching any **part** of the fixture.



Vortex 360 being installed in a fixture (required safety cable not shown).

OPERATION

The speed and rotation can be set by turning the potentiometer (on top of the unit) clockwise for faster and counter clockwise for slower. The direction of the rotation can be set by changing the position of the toggle switch. There is also an off feature (center position on the toggle switch) for changing gobos without having to unplug the unit or dial down the speed to 0.

Note: *The rotational speed of the Vortex 360 can be remotely controlled by plugging the power adapter into an electronic dimmer output (set the power adapter to 12V for best results). However, the dimmer output **must be compatible** for use with transformers. Please check with the dimmer manufacturer before using the Vortex 360 in this fashion. Failure to use a compatible dimmer can result in overheating and/or damage to both the Vortex 360 and the dimmer.*

PRECAUTIONS

- **Make sure gobos can rotate freely while in use.**
Jamming of a gobo wheel can cause the motor to burn out.
- **Make sure motor cover is facing the front of the fixture.**
Failure to do so can result in motor overheating.
- **Do not let Vortex 360 hang by power adapter cord.**
- **Always use a safety cable with the Vortex 360.**
- **After use, case may become very hot.** If unit must be handled, use handle as it is a thermoplastic and will remain cool to the touch.
- **Do not use the Vortex 360 with a dimmer if the dimmer is not rated for power adapters.**
- **Do not rapidly heat and cool glass gobos as this will likely cause them to break.** Ensure that you are using the flattest field possible will also reduce change of breakage.
- **Make sure power adapter cable is not touching any part of the fixture.**

TROUBLESHOOTING AND REPAIRS

Gobos Not Rotating and Vortex 360 Motor Not Running

Possibility #1 – Gears are jammed

Make sure nothing is preventing gears from rotating properly. If they will not rotate freely, don't try to force them. If they are jammed, remove the obstruction and test. Note that jammed gears may lead to a dead power adapter and/or motor.

Possibility #2 – Toggle switch is set to off (center position)

Change the position of the toggle switch.

Possibility #3 – Power adapter is dead

Meter pins 1 and 3 from the power adapter. The voltage read should match the switch position on the power adapter itself. Polarity is not important. Make sure the proper input voltage is selected with the switch. If output voltage is not within 15%, the transformer is not working properly.

Possibility #4 – Wires to motor have come off

Open cover and verify that wires have not become disconnected from motor. If this has occurred, simply solder back in place.

Possibility #5 – Motor is dead

If possible, attach a different power adapter to the unit to verify that it is not the power adapter. If everything else has been checked, then the motor should be replaced (see instructions later).

Disconnect power immediately! Further operation could damage motor and/or power adapter.

Gobos Not Rotating and Vortex Making Noise

Possibility #1 – Gears are jammed

Make sure nothing is preventing gears from rotating properly. If they will not rotate freely, don't try to force them. If they are jammed, remove the obstruction and test. Note that jammed gears may lead to a dead power adapter and/or motor.

Possibility #2 – Drive gear is loose

If it sounds like the motor is spinning, but no gears are turning, the drive gear on the motor shaft may be loose. This would also allow the rest of the gears to rotate freely. It can be fixed by tightening the set screw on the drive gear with a 1/16" Allen key.

Possibility #3 – Motor is dead

If possible, attach a different power adapter to the unit to verify that it is not the power adapter. If everything else has been checked, then the motor should be replaced.

CANNOT FOCUS IMAGE

Possibility #1 – Gobo is bent or broken

Remove Vortex 360 from fixture and check both gobos.

Possibility #2 – Problem with fixture

Insert new gobo in pattern holder and place in fixture. Make sure that image can focus properly. Consult fixture manufacturer if this is the problem.

REPLACING THE MOTOR

The Vortex 360 motor can be replaced fairly easily. You will need a $\frac{1}{16}$ " Allen key, needlenose pliers, small Phillips screwdriver, a soldering iron, and solder.

- 1) Open front cover of Vortex 360.
- 2) Use the soldering iron to disconnect the wires from the motor.
- 3) Use the $\frac{1}{16}$ " Allen key to loosen the set screw on the drive gear attached to the motor. If you cannot see the hole for the set screw in the side of the gear, you may need to use the screwdriver to rotate the gear.
- 4) Use the needle-nose pliers to loosen the motor attachment standoffs (2x, one on each side of the motor with a hex head at the top). Remove the standoffs, washer and "O" ring.
- 5) Lift the motor out and make sure not to lose the drive gear or motor pad.
- 6) Place the new motor into the Vortex 360 in place of the old one. Make sure that the motor pad is between the motor and the metal. You will need to put the shaft of the new motor through the drive gear as you do this.
- 7) Replace the motor attachment standoffs, "O" rings and washers and tighten with the needle-nose pliers (do not over-tighten).
- 8) Solder the motor wires onto the new motor.
- 9) Attach the power adapter and make sure the motor rotates properly (the shaft can be seen through the rear plate). The gears will probably not rotate. Stop the motor when the flat side of the shaft is facing the side of the unit.
- 10) Rotate the drive gear until the set screw is aligned with the flat side of the motor shaft. Tighten down the set screw. Drive gear should no longer spin freely.
- 11) Test Vortex 360 out of the fixture to make sure it is all working properly.

VORTEX 360 SPECIFICATIONS

Size	HxWxD - 12.5" x 4.75" x 2.5" (319mm x 120mm x 64mm) Unit - 2lb. 12oz lbs. (1.25 kg) Power adapter - 0.625 lbs. (.28 kg)
Supported Fixtures	ETC Source 4 Altman 1KL
Supported Gobo Size	Standard B Size - 2.5" (64.5mm) image size Maximum - 3.38" (86mm) outer diameter.
Power Supply	Plug-In transformer with NEMA 1-15 Plug 120 and 240 volt versions, 50/60Hz, 6W MAX, 100/.06amps, 120/.05, 200/.03, 240/.025 Output -12VDC, 6W Maximum Switchable Polarity Cord Length - 52" (1320mm) Connector - 3-pin Male DIN

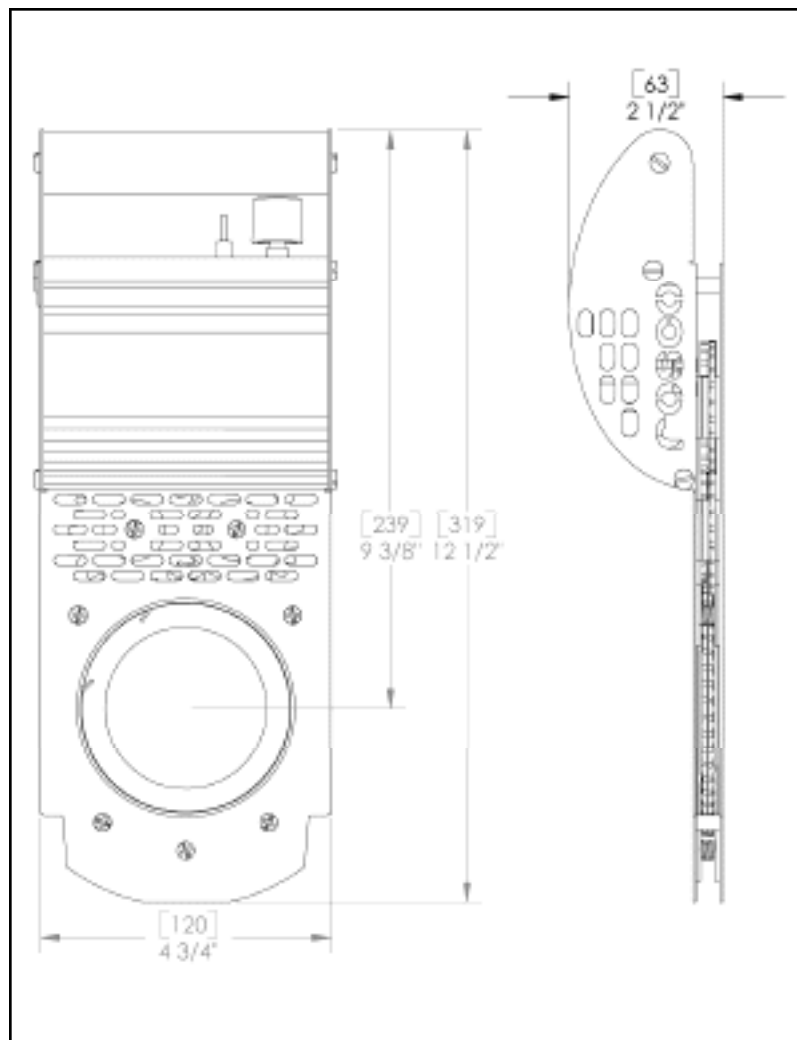

Dimensioned Vortex 360

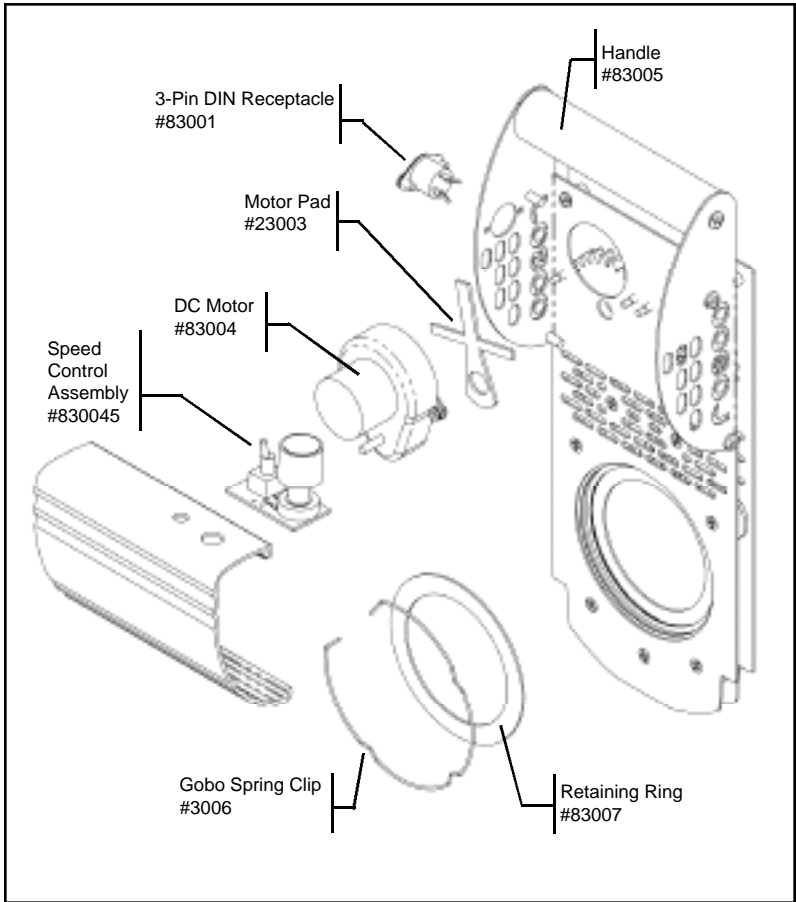

Replacement Parts

Replacement power adapter; #840000120

Repairs, Warranty Issues and Parts

For all repairs, warranty issues and parts needs, please contact our service center.

ROTAD

**1330 30th St., Suite G,
San Diego, CA 92154
800-468-0114 ext. 25**

You can also call your local Rosco dealer for parts and information.



Rosco Laboratories, Inc.

52 Harbor View Ave., Stamford, CT 06902
(203) 708-8900 1 (800) ROSCO NY FAX (203) 708-8919
1265 Los Angeles St., Glendale, CA 91204
(818) 543-6700 1 (800) ROSCO LA FAX: (818) 662-9470

Rosco Laboratories, Ltd.

1241 Denison St. #44, Markham, Ontario, Canada L3R 4B4
(905) 475-1400 (888) ROSCO TO FAX: (905) 475-3351

Roscolab, Ltd.

Blanchard Works, Kangley Bridge Rd., Sydenham, London SE26 5AQ England
(20) 8659-2300 FAX: (20) 8659-3153

Rosco Iberica, S.A.

Rosco Iberica, S.A.
C/ Perfumeria, 21. Nave 8. Pol. Ind. La Mina, 28770 Colmenar Viejo, Madrid, Spain
(34) 918-473-900 Fax: (34) 918-463-634

Rosco do Brasil Ltda.

Rua Antonio De Barros, 827, São Paulo SP Brasil CEP 03401-000
(11) 218-2865 FAX: (11) 218-0193

Rosco Australia Pty Ltd.

42 Sawyer Lane, Artarmon 2064, New South Wales, Australia
(02) 9906-6262 FAX: (02) 9906-3430