

*Model WM1000/WM2000
Wall Mount Intercom Stations
User Instructions*

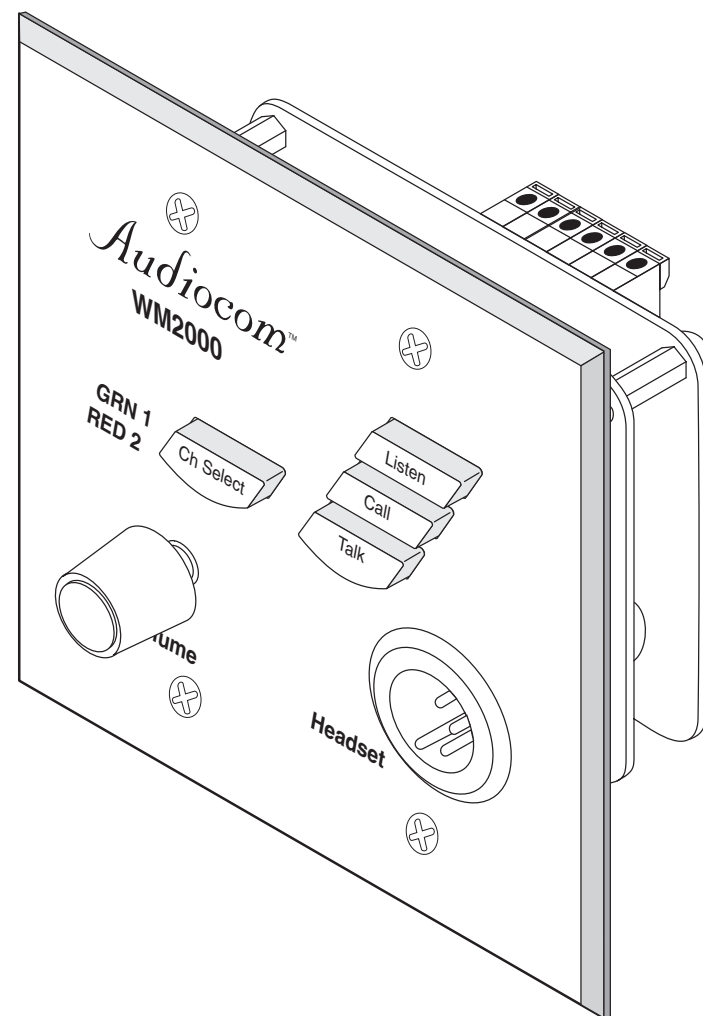

PROPRIETARY NOTICE

The product information and design disclosed herein were originitive by and are the property of Telex Communication, Inc. Telex reserves all patent, proprietary design, manufacturing, reproduction, use and sales rights thereto, and to any article disclosed therein, except to the extent rights are expressly granted to others.

COPYRIGHT NOTICE

Copyright 2006 by Telex Communications, Inc. All rights reserved. Reproduction, in whole or in part, without prior written permission from Telex is prohibited.

WARRANTY NOTICE

See the enclosed warranty card for further details.

CUSTOMER SUPPORT

Technical questions should be directed to:
Customer Service Department
RTS/Telex Communications, Inc.
12000 Portland Avenue South
Burnsville, MN 55337 U.S.A.
Telephone: 800-392-3497
Fax: 800-323-0498
Factory Service: 800-553-5992

RETURN SHIPPING INSTRUCTIONS

Customer Service Department
Telex Communications, Inc. (Lincoln, NE)
Telephone: 402-467-5321
Fax: 402-467-3279
Factory Service: 800-553-5992

Please include a note in the box which supplies the company name, address, phone number, a person to contact regarding the repair, the type and quantity of equipment, a description of the problem and the serial number(s).

SHIPPING TO THE MANUFACTURER

All shipments of product should be made via UPS Ground, prepaid (you may request from Factory Service a different shipment method). Any shipment upgrades will be paid by the customer. The equipment should be shipped in the original packing carton. If the original carton is not available, use any suitable container that is rigid and of adequate size. If a substitute container is used, the equipment should be wrapped in paper and surrounded with at least four (4) inches of excelsior or similar shock-absorbing material. All shipments must be sent to the following address and must include the Proof of Purchase for warranty repair. Upon completion of any repair the equipment will be returned via United Parcel Service or specified shipper, collect.

Factory Service Department
Telex Communications, Inc.
8601 East Cornhusker Hwy.
Lincoln, NE 68507 U.S.A.
Attn: Service

FCC STATEMENT

This equipment uses, and can radiate radio frequency energy that may cause interference to radio communications if not installed in accordance with this manual. The equipment has been tested and found to comply with the limits of a Class A computing device pursuant to Subpart J, Part 15 of FCC Rules which are designed to provide reasonable protection against such interference when operated in a commercial environment. Operation of this equipment in a residential area may cause interference which the user (at his own expense) will be required to correct.

 This product meets
Electromagnetic Compatibility
Directive 89/336/EEC

Notes

Notes

Introduction

Thank you for purchasing the Audiocom WM1000/2000 Wall Mount Intercom Station. We hope the many design features of this product will satisfy your intercommunication requirements for many years to come. To get the most out of your new intercom station, please take a few moments to look through this booklet before using the Intercom Station for the first time.

Description

The WM1000/2000 Intercom Stations are designed for stationary, wall-mounted installation in standard two-gang electrical boxes. The WM1000 is a single-channel station; the WM2000 provides switch-selectable access to either of two intercom channels. The WM1000 and WM2000 are ideal when users need to access the intercom system from strategic locations where a desktop station would be unsuitable, but they do not wish to carry around a belt-pack station. Since all of the intercom electronics are in the intercom station, the user need only connect a headset or telephone style handset to begin communicating. Alternatively, a headset or telephone handset can be left right at the station.

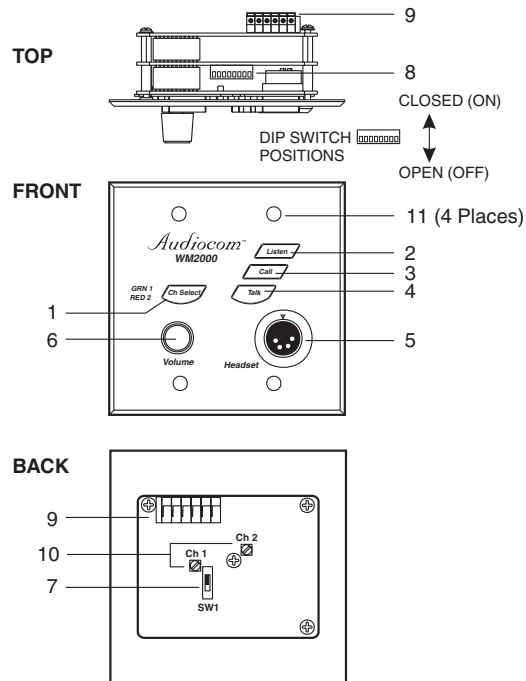

Figure 1. Reference View, WM-2000 shown (see numbered features list).

Mic-Kill Detect Frequency:

24 kHz \pm 800 Hz, 100 mVRMS

Noise Contribution:

less than -70 dB

Common Mode Rejection Ratio:

greater than 50dB

Connector Type:

Six-position terminal block with screw-in wire clamps

Pin 1 Audio and DC Common

Pin 2 Local power (12 to 15 VDC, 65 to 150 mA)

Pin 3 Intercom channel 1 audio low and +24 VDC phantom power

Pin 4 Intercom channel 1 audio high and +24 VDC phantom power

Pin 5 Intercom channel 2 audio low and +24 VDC phantom power

Pin 6 Intercom channel 2 audio high and +24 VDC phantom power

Intercom Channel, Unbalanced Mode (SW-1 set to UNBAL position)

Output Level:

1 VRMS \pm 10%

Input Impedance:

150 ohms

Bridging Impedance:

greater than 10,000 ohms

Sidetone:

-40 dB, 35 dB adjustable range

Call Signaling:

Send:

11 \pm 3 VDC

Receive:

4 VDC minimum

Connector Type:

Six-position terminal block with screw-in wire clamps

Pin 1 Common

Pin 2 Local power (12 to 15 VDC, 65 to 150 mA)

Pin 3 Channel 1 +24 VDC input

Pin 4 Channel 1 intercom audio high and DC call

Pin 5 Channel 2 +24 VDC input

Pin 6 Channel 2 intercom audio high and DC call

Specifications

General

Power Requirements

Phantom Power:

24VDC nominal (12 to 30 VDC), 65 to 150 mA

Local Power:

12 to 15 VDC, 65 to 150 mA

Dimensions

Mounts in a standard two-gang electrical box

Environmental Requirements

Storage:

-20° C to 80° C; 0% to 95% humidity, non-condensing

Operating:

-15° C to 60° C; 0% to 95% humidity, non-condensing

Dynamic-Mic Headset

Microphone:

50 to 200 ohm, dynamic (balanced or unbalanced)

Headphones:

150 to 600 ohm, monaural

Connector Type:

XLR-4M

Pin 1 Microphone Low

Pin 2 Microphone High

Pin 3 Headphone High

Pin 4 Headphone Low

Intercom Channels, Balanced Mode (SW1 set to BAL position)

Output Level:

1 V_{RMS} nominal

Input Impedance:

300 ohms

Bridging Impedance:

greater than 10,000 ohms

Sidetone:

-40 dB, 35 dB adjustable range

Call Signaling

Send:

20 kHz ±100 Hz, 0.5 V_{RMS} ±10%

Receive:

20 kHz ±800 Hz, 100 mV_{RMS}

Features

1. Channel Select Switch (WM-2000 Only): Used to switch between intercom channels one and two. The switch lights green for channel one and red for channel two.
2. Intercom Listen Key: Both momentary (push-to-listen) and latching (hands-free-listen) are possible.
3. Call Key: Used to send call signals on the intercom channel and to indicate incoming calls.
4. Intercom Talk Key: Both momentary (push-to-talk) and latching (hands-free-talk) are possible.
5. Dynamic-Mic Headset Connector: 4-pin male XLR connector accepts headsets with monaural headphones and either a balanced or unbalanced dynamic microphone.
6. Volume Control: Adjusts intercom volume to headphones.
7. Audiocom / Clear-Com Selector Switch: The selector switch sets the intercom station for compatibility with either Audiocom or Clear-Com channel connector pin-outs, channel power requirements, and call signaling requirements.
8. Configuration DIP Switches: DIP switches are provided to enable/disable the following features:
 - Mic Kill: With this feature activated, the station's microphone may be turned off from a remote master controller.
 - Call Beep: An optional call beep tone can be used for incoming call notification.
 - Headset Microphone Type Selection: Balanced or unbalanced microphone may be selected.
 - DC Call Enable: This may be turned on to use the intercom station with intercom systems that use DC call signaling.
9. Connections Terminal Block: Used to connect intercom channel(s) and an optional local power supply.
10. Sidetone Trimmers: These are used to adjust the level of the station operator's own voice in the headphones.
11. Mounting Holes: The mounting holes fit any standard, two-gang electrical box.

Installation

Unpacking

Each WM1000/2000 is supplied with the following items. Contact the shipper or your Audiocom dealer immediately if anything is damaged or missing. Detach and fill out the registration card and return it to Telex to properly register your intercom station.

Quantity	Description
1	WM1000 or WM2000 Intercom Station
1	Warranty and Registration Card
1	User Instructions
4	Mounting Screws

Configuration Switch Pre-check

Before making connections, read the configuration switch notes that follow and make sure that all switches are properly set for your intended usage. Table 1 lists the switch descriptions and factory default settings. Figure 1 shows the locations of the switches.

Mic Kill DIP Switch (DIP Switch 1)

Audiocom master stations can transmit an inaudible signal to turn off the microphones in all remote intercom stations (including WM1000/2000) on an intercom channel. This is useful when a remote intercom station has been left unattended with the microphone on. The procedure to use this feature from a master station is a two-step process so that it is very unlikely that microphones will ever be turned off by accident. However, you may wish to disable the mic kill feature at the WM1000/2000 if communications will be of a critical nature where it is absolutely essential the microphone never be remotely deactivated.

DC Call Enable (DIP Switch 2)

Leave this switch in the open position for Audiocom applications. Set it to the closed position if the WM1000/2000 will be used in a Clear-Com intercom system.

Incoming Call Beep (DIP Switch 3)

By default, incoming calls are indicated by a red-flashing Call key and a beep tone in the headphones. If you do not want the beep tone, set DIP switch 3 to the closed position.

Operation

Channel Select (WM2000 Only)

Tap the Ch Select key to select channel 1 or 2. The key is green when channel 1 is selected and red when channel two is selected.

Receiving Calls

1. When there is an incoming call signal the Call key will flash red. There will also be a beep tone in the headphones if the beep feature is activated (page X).

NOTE: WM2000 only: incoming call indication is provided only for the currently selected channel.

2. Turn on the Talk and Listen keys and begin your conversation.

NOTE: You can turn the talk and listen keys on in either momentary or latched mode. For latched operation, tap the key to turn it on Then tap it again to turn it off when finished.

Calling an Intercom Channel

1. WM2000 only: select the desired intercom channel.
2. Press and hold the Call key.
An inaudible call signal will be sent, and the Listen key will automatically turn on.
3. When you hear a response, release the Call key and activate the talk key.
4. Turn off your Talk and Listen keys to end the conversation.

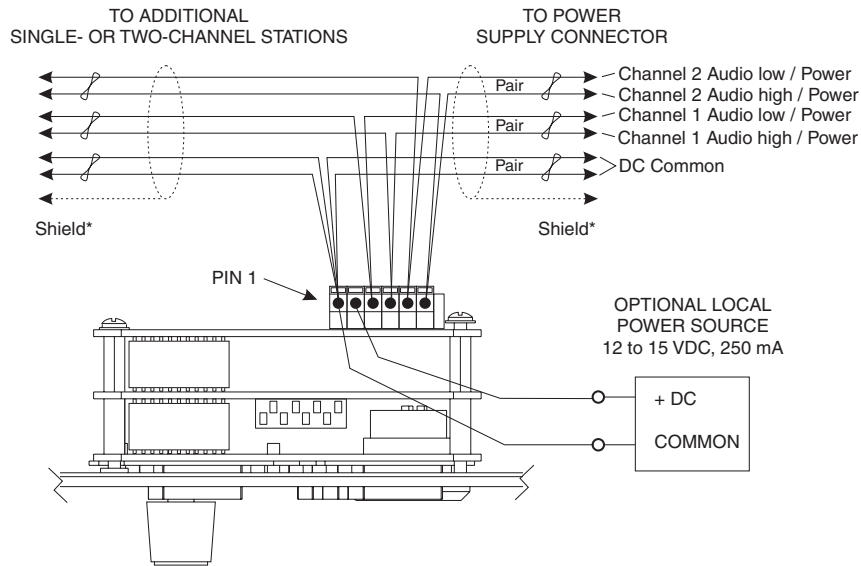

Cable Type: 22AWG Stranded, 3-Pair Twisted-wire, with Shield

⌘ Denotes twisted pair.

○ Denotes shield.

*Shield: Earth ground (Connect at power supply only. Do not short to DC common)

Figure 7. Audiocom mode connections for a WM2000 Intercom Station.

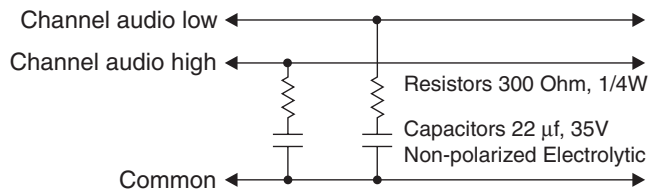

Figure 8. Audiocom mode line termination for dry-line operation. (One required for each channel).

Switch Number	Description	Settings	Default Setting
1	Mic Kill Receive	Closed: Disabled, no mic kill Open: Enabled, mic kill active	Open
2	Call Signal Method	Closed: DC Open: Audiocom	Open
3	Incoming Call Beep	Closed: Disabled Open: Active	Open
4	Microphone Type	Closed: Unbalanced Open: Balanced	Open
5	Not Used	N/A	Open
6	Not Used	N/A	Open
7	Not Used	N/A	Open
8	Not Used	N/A	Open

Table 1. Configuration Switch Settings

Headset Microphone Type Selection (DIP Switch 4)

If the headset specifications indicate the microphone type is balanced, or if you are unsure, leave this switch in the off (default) position. If the specifications indicate an unbalanced microphone, set DIP switch 2 to on.

Balanced/Unbalanced Switch (SW-1)

This switch is set at the factory to the balanced (BAL) position for use with Audiocom intercom channels. Set the switch to the unbalanced (UNBAL) position for use with Clear-Com intercom systems. Be sure and use the appropriate connection information based on how you have this switch set.

Intercom Channel Connections

Important!

The following paragraphs and illustrations describe installation of the WM1000/2000 in an Audiocom Intercom System. To use the WM1000/2000 in a Clear-Com Intercom System, set SW1 to the UNBAL position, set DIP switch 2 to the Closed position, and connect the Clear-Com channel wires using the Unbalanced Mode Intercom Channel pin-out information listed in the specifications.

General Information

NOTE: After connecting intercom stations as described below, and before installing the mounting screws, connect a headset and perform the sidetone adjustment as described on page 10.

The WM1000/2000 mounts in a standard two-gang electrical box. Some example intercom system configurations are showing the Figures 2 through 5, pages 11 through 13. Detailed connections for the WM1000/2000 are shown in Figures 6 and 7, pages 13 and 14. There are two basic methods for connecting the WM1000/2000: 1) using a phantom powered connection, and 2) using local power. The two methods are discussed below.

Method 1: Phantom Powered Connection

In this method, operating power and intercom audio are delivered to the WM1000/2000 over the same wires. The advantage of this setup is simplicity of connection. Also, the Audiocom power supply automatically provides terminating impedance for the intercom system. Without this terminating impedance, the sound quality on the channel will be very distorted, and the levels will shift every time additional stations are connected to the channel. The disadvantage of the phantom power method is that some operating power is lost over very long intercom cables, and performance will then be reduced at remotely located stations. Generally, if the intercom stations are located within a few hundred feet of the power supply, the phantom power will be sufficient. The actual distance over which power can be delivered can vary, however, depending on the number of stations connected. Increasing the number of stations will reduce the distance. Note, the range over which power can be delivered is independent from the range over which audio can be sent. Audio can be transmitted for several miles, providing that intercom stations are locally powered, as described below.

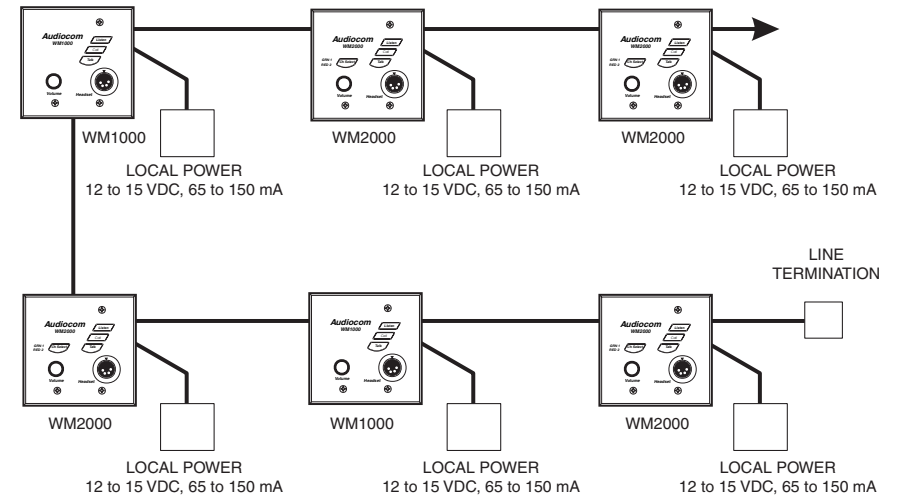
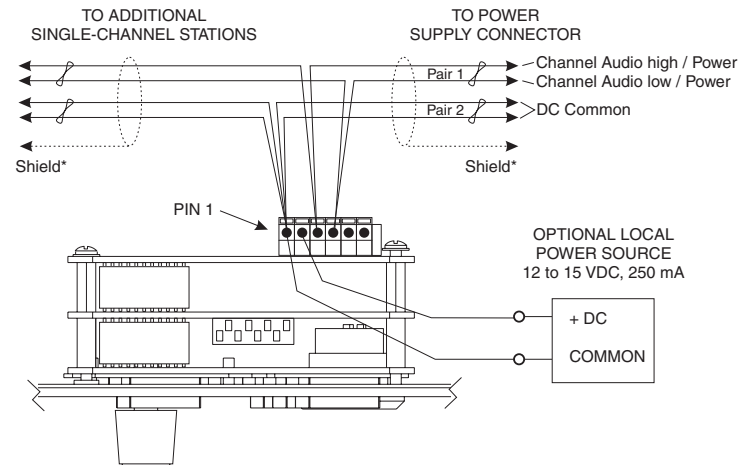

Figure 5. An example of an intercom system using all local powered stations, with no power being distributed on the intercom channels (dry lines). WM2000 stations are shown, but WM1000 stations may also be used. Since an Audiocom power supply is not used, the installer must connect a line termination somewhere in each channel for proper operation. The required line termination is shown in Figure 8.



Cable Type: 22AWG Stranded, 2-Pair Twisted-wire, with Shield

⌘ Denotes twisted pair.

⌘ Denotes shield.

*Shield: Earth ground (Connect at power supply only. Do not short to DC common)

Figure 6. Audiocom mode connections for WM1000 Intercom Station.

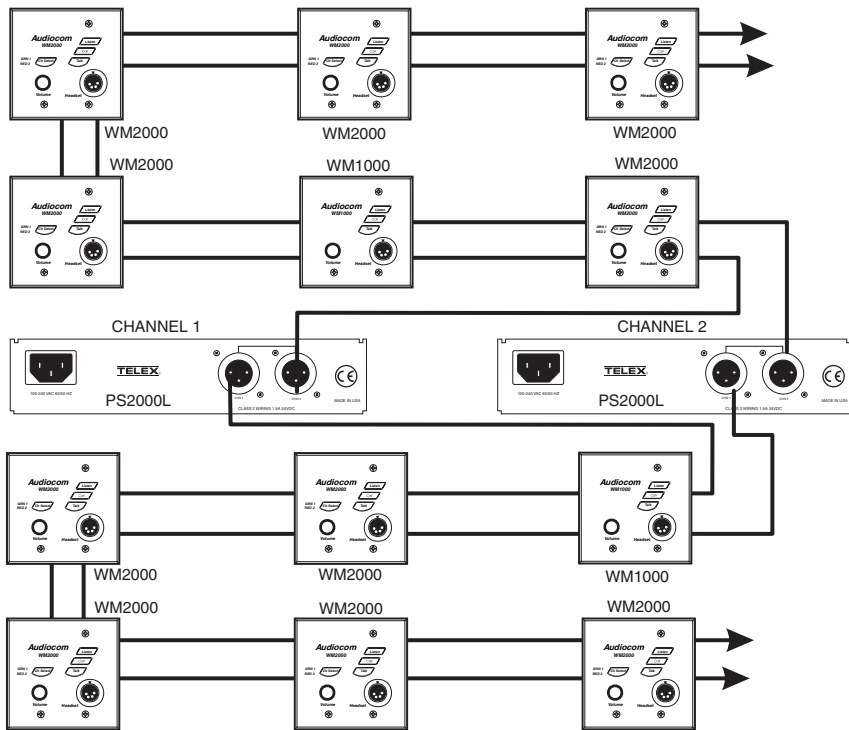

Figure 4. A two-channel intercom system using two PS2000L power supplies. Each PS2000L is set to combine mode and it supplies power to one intercom channel only. Each intercom channel is a separate party line, and total current for each channel is limited to 2 amps. Note, both WM1000 and WM2000 Intercom Stations may be connected, depending on each locations' need to communicate with one or two intercom channels. For WM1000 connection details, refer to Figure 6; for the WM2000 refer to Figure 7.

Method 2: Locally Powered Connection

Using this method, the intercom station is connected to the intercom line just like any phantom-powered intercom station, except that a local power supply is also connected. This local power supply is located right with the intercom station and provides power for that station only. Since power loss on the intercom lines is no longer an issue, the operating range is now limited only by the audio transmission range, which is several miles. Another advantage to this method is more stations can be connected to the intercom channels. When local power is supplied to an intercom station, the station detects this and automatically disconnects from the phantom power supply. As long as an Audiocom power supply is located somewhere in the intercom system, the proper terminating impedance will still be supplied for all stations.

All Locally Powered Intercom Stations (Dry Lines)

If all intercom stations are widely distributed, you can dispense with a main power supply and use local power for each station. When no power is delivered on the intercom channels, this is known as dry-line operation. However, since an Audiocom power supply is not used, a line termination must be inserted in each intercom channel for proper operation. Figure 5, page 13 shows an example of dry line operation. The required termination components are shown in Figure 8, page 14.

Dynamic-Mic Headset Connection

NOTE: For headset specifications, see page 16. For best results in noisy environments, a noise canceling (directional or cardioid) microphone is highly recommended.

1. Make sure DIP switch 4 is properly set for balanced or unbalanced microphone. See Table 1 page 7.
2. Plug the headset into the headset connector. Power up the intercom system and check the sidetone adjustment before placing the station in operation.

Power- Up

Make sure any local power supplies are plugged in, and turn on the power switches of any phantom power supplies.

NOTE: If you are using a large number of locally powered intercom stations, you should activate their local power supplies before activating any phantom power supply. Otherwise, you may get an overload indication on the phantom supply. In this case, either reset the phantom supply, or momentarily turn it off, then on.

Sidetone Adjustment

The WM1000/2000 uses full-duplex audio (the same as conventional telephone lines) in which the talk and listen audio are sent and received on the same wires. Thus, when you talk on a channel, you will also hear your own voice back in the headphones. If you are using open-ear style headphones, this could cause unwanted feedback, since the microphone may pick up your returned voice audio and re-amplify it. On the other hand, if you are using headphones that completely enclose the ears, a certain amount of your own voice level is desirable to overcome the muffled sensation when talking. The sidetone adjustment is different for these two situations.

If you are using open-ear style headphones, adjust sidetone as follows:

1. Activate channel 1 as described in the operating instructions. (Required only for the WM2000, the WM1000 is active on whichever channel it is connected to.)
2. Activate talk and listen as described in the operating instructions.
3. Slowly increase the volume to maximum while talking into the microphone.
4. Using a small, flat-bladed screwdriver, adjust channel 1 sidetone trimmer (Figure 1) to minimize your voice level in the headphones.
5. For the WM2000 only, activate channel 2 and repeat the above steps to adjust channel 2 sidetone.
6. Install the intercom station mounting screws after completing the adjustments.

The station is now ready for use.

If you are using headphones that completely enclose the ears, adjust sidetone as follows:

1. Activate channel 1 as described in the operating instructions. (Required only for WM2000, the WM1000 is active on whichever channel it is connected to.)
2. Activate talk and listen as described in the operating instructions.
3. Set the volume control to the normal listening level for intercom audio.
4. While talking into the microphone, use a small, flat-bladed screwdriver to adjust the channel 1 sidetone trimmer (Figure 1) so that you can hear your own voice in the headphones at an acceptable level.
5. For the WM2000 only, activate channel 2 and repeat the above steps to adjust the channel 2 sidetone.
6. Install the intercom station mounting screws after completing the adjustments.

The station is now ready for use.

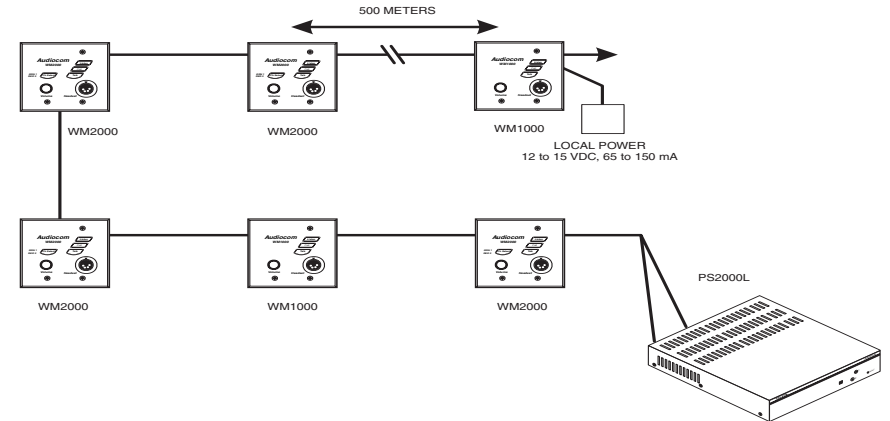

Figure 2. A two-channel intercom system using a PS2000L Power Supply set to isolate mode. In isolate mode, each intercom channel is a separate party line, and total current for each channel is limited to 1 amp. Note, both WM1000 and WM2000 stations may be connected, depending on each locations' need to communicate with one or two channels. WM1000 stations may be connected to either channel one or two. Also note, locally powered stations may be connected. This is recommended when stations are installed at remote locations. Since the PS2000L provides termination for the intercom channels, no user-installed termination is required. For WM1000 connection details refer to Figure 6; for the WM2000, refer to Figure 7.

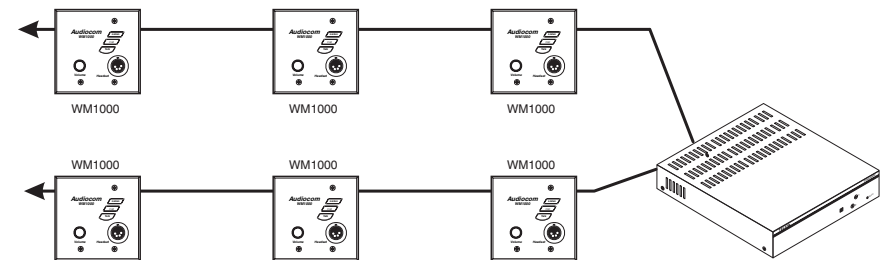

Figure 3. A single-channel intercom system using one PS2000L with WM1000 Intercom Stations. The PS2000L may be set to either combine or isolate mode. In combine mode, all intercom stations talk on a single party line, and total current for the channel is 2 amps. In isolate mode, one string of intercom stations is operated as channel one, and the other string is operated at channel two. There is no communication between the separate channels, and the total current per channel is 1 amp. For WM1000 connection details, refer to Figure 6.