

ELED Fresnel 100WW

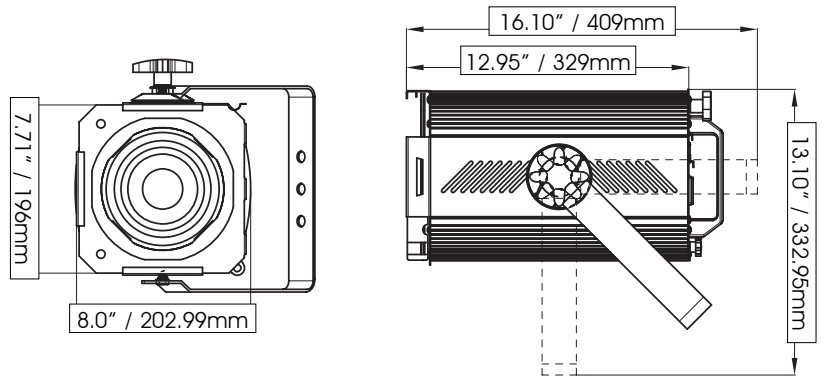

ELED Fresnel 100WW Dimensions

The ELED Fresnel 100WW by Elation Professional is a high power LED warm white light fresnel featuring 1 x 100W LED lamp, 600W halogen equivalent, optimized providing up to 50,000 hours estimated LED life, 120W power consumption, fan cooled and multi-voltage electronic power supply. This unit is rated IP 20, ideal for indoor applications and control data input is via 3 and 5 pin DMX data first in and out connections. The ELED Fresnel 100WW features 10° to 50° manual zoom, internal DMX control for dimmer / strobe and is operable via 1 or 2 channel DMX modes. The maximum output intensity of channel 1 can be preset by adjusting onboard menus 5 and 6. Gel frame and barn door kit are included and rigging for this unit includes single yoke bracket, safety and data cable are optional.

FEATURES

- High power LED warm white light fresnel
- Internal DMX Control for Dimmer / Strobe
- 100 Watt LED Engine
- 3,800k White LED CCT
- 600W Halogen Equivalent
- 10° to 50° manual zoom
- Rated IP 20
- Case Color: Black
- Cooling: Fan Cooled
- Multi-voltage electronic power supply
- LED Menu Display
- DMX controllable via 1 or 2 channel DMX modes
- Gel Frame and barn door kit Included
- On Board Control
- Stand Alone
- Flicker Free

TECHNICAL SPECIFICATIONS

- **DMX Channels:** 1, or 2 channels, 2 DMX control modes
- **Control:** USITT DMX-512, 3 pin and 5 pin XLR data input & output
- **Dimmer:** 0- 100% Smooth Dimming via DMX
- **Strobe:** Strobe effect (1-18 flashes per second)
- **IP Rating:** IP 20
- **Power Supply:** Electronic, multi-voltage 120v-240V 50/60hz
- **Power Consumption:** 120W
- **Cable / Plug Type:** IEC 120v US
- **Approvals:** CE Approved - ETL Pending
- **Lamp:** 1 x 100W
- **Lamp Life:** 100W, 3,800K, 50,000 hrs. life
- **Lux:** 1,100 lux / 102 fc @ 10' / 3M
- **Dimensions:** (LxWxH) 14.5" x 9.84" x 14.5" / 368.3 x 250 x 368.3mm
- **Weight:** 11.6 lbs / 5.3 kg
- **Rigging:** Single Yoke Bracket / safety and data cable optional

ELED Fresnel 100WW



COLORS

- High power LED warm white light fresnel
- 100W 3,800k Warm White LED Module

Barn door beam shaping options

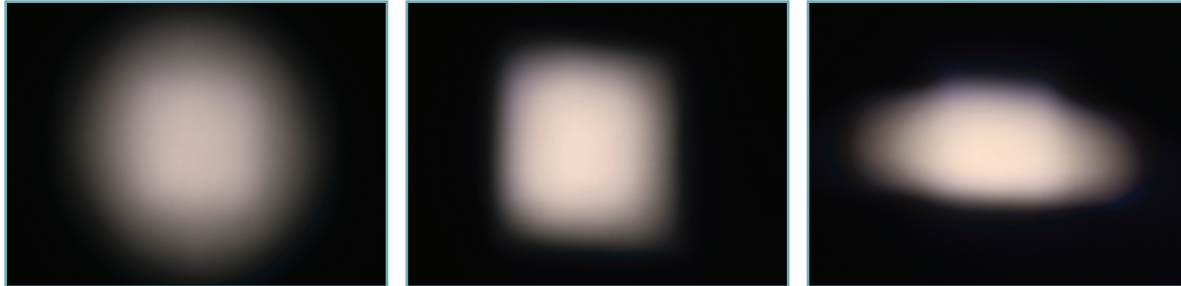

DMX TRAITS

1 Channel Mode:

Channel	Value	Function
1	1 - 255	Intensity 0% - 100%

2 Channel Mode:

Channel	Value	Function
1	1 - 255	Intensity 0% - 100%
2	1 - 255	Strobing slow-fast