

*Notif*tm
architectural by blizzard

atelier.16fx

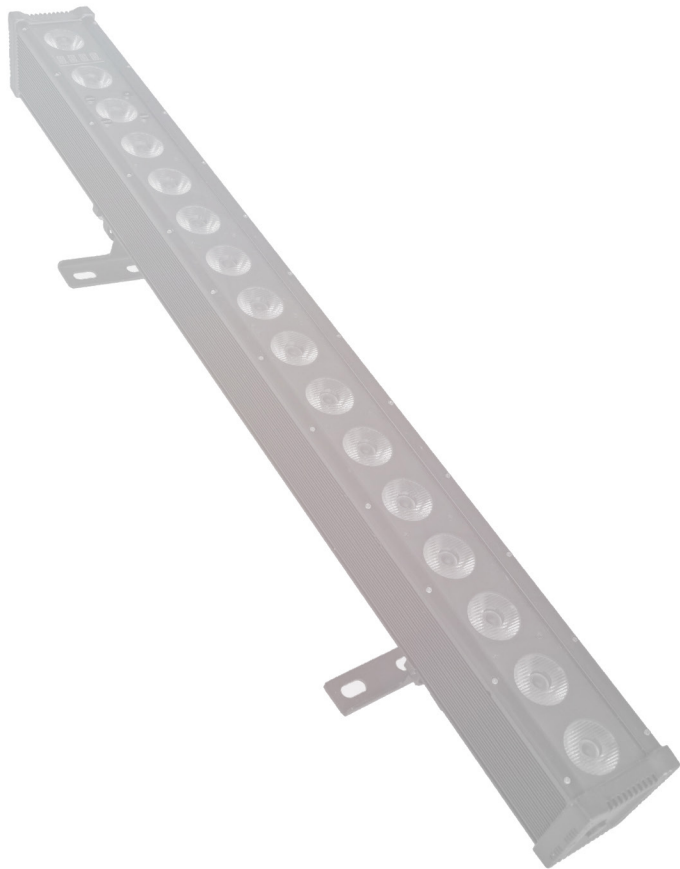

DMX512 equipped



IP65 rated

TABLE OF CONTENTS

Motif™ Atelier 16FX	1
1. Getting Started	3
What's In The Box?	3
Getting It Out Of The Box	3
Powering Up!	3
Getting A Hold Of Us	3
Safety Instructions (Don't Stick Your Hand In The Toaster!)	4
2. Meet The Motif™ Atelier 16FX	5
Features	5
DMX Quick Reference	5
The Motif™ Atelier 16FX Pin-up Picture	6
3. Setup	7
Fuse Replacement	7
Connecting A Bunch Of Motif™ Atelier 16FX Fixtures	7
Data/DMX Cables	7
Cable Connectors	8
3-Pin??? 5-Pin??? Huh?	8
Take It To The Next Level: Setting up DMX Control	8
Fixture Linking (Master/Slave Mode)	9
Mounting/Rigging	9
4. Operating Adjustments	10
Navigating The Control Panel	10
Control Panel Menu Structure	11
DMX Mode	12
Slave Mode	12
Dimming Mode Settings	12
LED Display Settings	12
Custom Programs	13
Auto Mode and Speed Settings	13
Color Calibration Settings	14
Custom Static Colors	14
Fixture Reset Functions	14
Data Sync Feature	15
Fixture ID Settings	15
Fixture Information	15
DMX Value In-Depth Reference Guide	16
LED Pixel Group Configurations	17
DMX In-Depth Reference	18
5. Appendix	20
A Quick DMX Lesson	20
Troubleshooting	20
Keeping Your Motif™ Atelier 16FX As Good As New	21
Returns (Gasp!)	21
Shipping Issues	21
Tech Specs	22
Dimensional Drawings	23

1. GETTING STARTED

What's In The Box?

- 1 x Motif™ Atelier 16FX LED Fixture
- 1 x IP-rated Power Cord
- 1 x DMX Signal Cable
- Stainless-Steel Bracket Screws (for vertical mounting)
- This Lovely User Manual

Getting It Out Of The Box

Congratulations on purchasing the Motif™ Atelier 16FX. Now that you've got your fixture, you should carefully unpack the box and check the contents to ensure that all parts are present and in good condition. If anything looks as if it has been damaged in transit, notify the shipper immediately and keep the packing material for inspection. Again, please save the carton and all packing materials. If a fixture must be returned, it is important that the fixture be returned in the original factory box and packing.

Powering Up!

All fixtures must be powered directly off a switched circuit and **cannot be run off a rheostat (variable resistor) or dimmer circuit, even if the rheostat or dimmer channel is used solely for a 0% to 100% switch.**

AC Voltage Switch - Not all fixtures have a voltage select switch, so please verify that the fixture you receive is suitable for your local power supply. See the label on the fixture or refer to the fixture's specifications chart for more information. A fixture's listed current rating is its average current draw under normal conditions. Check the fixture or device carefully to make sure that if a voltage selection switch exists that it is set to the correct line voltage you will use.

Warning! Verify that the voltage select switch on your unit matches the line voltage applied. Damage to your fixture may result if the line voltage applied does not match the voltage indicated on the voltage selector switch. All fixtures must be connected to circuits with a suitable Ground (Earthing).

Getting A Hold Of Us

If something is wrong, please just visit our website at www.blizzardpro.com and open a support ticket. We'll be happy to help, honest.

Disclaimer: The information and specifications contained in this document are subject to change without notice. Blizzard Lighting™ assumes no responsibility or liability for any errors or omissions that may appear in this user manual. Blizzard Lighting™ reserves the right to update the existing document or to create a new document to correct any errors or omissions at any time. You can download the latest version of this document from www.blizzardpro.com.

Author:	Date:	Last Edited:	Date:
J. Thomas	7/21/2018	J. Thomas	5/7/2024

SAFETY INSTRUCTIONS



Please read these instructions carefully. They include important information about the installation, usage and maintenance of this product.

- Please keep this User Guide for future use. If you sell the unit to someone else, be sure that they also receive this User Guide.
- ALWAYS make sure that you are connecting to the proper voltage, and that the line voltage you are connecting to is not higher than that stated on the decal or rear panel of the fixture.
- Make sure there are no flammable materials close to the unit while operating.
- The unit must be installed in a location with adequate ventilation, at least 20in (50cm) from adjacent surfaces. Be sure that no ventilation slots are blocked.
- ALWAYS disconnect from the power source before servicing or replacing fuse and be sure to replace with same fuse size and type.
- ALWAYS secure fixture using a safety chain. NEVER carry the fixture by its head. Use its carrying handles.
- DO NOT operate at ambient temperatures higher than 104°F (40°C).
- In the event of a serious operating problem, stop using the unit immediately. NEVER try to repair the unit by yourself. Repairs carried out by unskilled people can lead to damage or malfunction. Please contact the nearest authorized technical assistance center. Always use the same type spare parts.
- NEVER connect the device to a dimmer pack.
- Make sure the power cord is never crimped or damaged.
- Never disconnect the power cord by pulling or tugging on the cord.
- Avoid direct eye exposure to the light source while it is on.

Caution! There are no user serviceable parts inside the unit. Do not open the housing or attempt any repairs yourself. In the unlikely event your unit may require service, please open a support ticket at www.blizzardpro.com/support.

2. MEET THE MOTIF™ ATELIER 16FX

MAIN FEATURES

- Color mixing via 16x 15W RGB+WW 4-in-1 LEDs
- 10-40° asymmetrical beam spread
- IP65 rated outdoor LED fixture
- Built-in color and pixel chase macros via DMX
- Virtual color wheel effect
- 33 built-in automated programs
- 10 custom color, and 3 custom program banks
- RGB+WW color mixing ability in standalone mode
- Custom global color calibration settings
- Variable electronic dimmer & strobe
- Sync custom settings between fixtures via DMX
- Fixture ID addressing
- Easy to use LED control panel
- Durable cast aluminum housing
- Tempered glass lens and watertight internal gaskets
- IP rated power and 3-pin input/output connections
- Efficient convection cooling for zero fan noise
- Mounting bracket with locking knobs for positioning flexibility
- Flicker-free constant-current LED driver
- IP rated 3-pin male input and 3-pin female output
- IP rated powerCON-compatible AC In/Out connections

DMX Quick Reference (4/5/10/16/24/40/72-Channel Modes)

Ch.	72-Channel
1	Dimmer
2-65	Individual Pixel Control
66	Strobe
67	Effect
68	Speed
69	Virtual Color Wheel
70	Dimming Modes
71	ID Function
72	ID Address

Ch.	24-Channel
1	Dimmer
2-17	4 Pixel Groups (4x4)
18	Strobe
19	Effect
20	Speed
21	Virtual Color Wheel
22	Dimming Modes
23	ID Function
24	ID Address

Ch.	64-Channel
1-64	Individual Pixel Control

Ch.	10-Channel
1	Dimmer
2-5	Full Bar Color Mixing
6	Strobe
7	Effect
8	Speed
9	Virtual Color Wheel
10	Dimming Modes

Ch.	40-Channel
1	Dimmer
2-33	8 Pixel Groups (2x8)
34	Strobe
35	Effect
36	Speed
37	Virtual Color Wheel
38	Dimming Modes
39	ID Function
40	ID Address

Ch.	16-Channel
1	Dimmer
2-9	2 Pixel Groups (8x2)
10	Strobe
11	Effect
12	Speed
13	Virtual Color Wheel
14	Dimming Modes
15	ID Function
16	ID Address

Ch.	5-Channel
1	Dimmer
2-5	Full Bar Color Mixing

Ch.	4-Channel
1-4	Full Bar Color Mixing

Figure 1: The Motif™ Atelier 16FX Pin-Up Picture

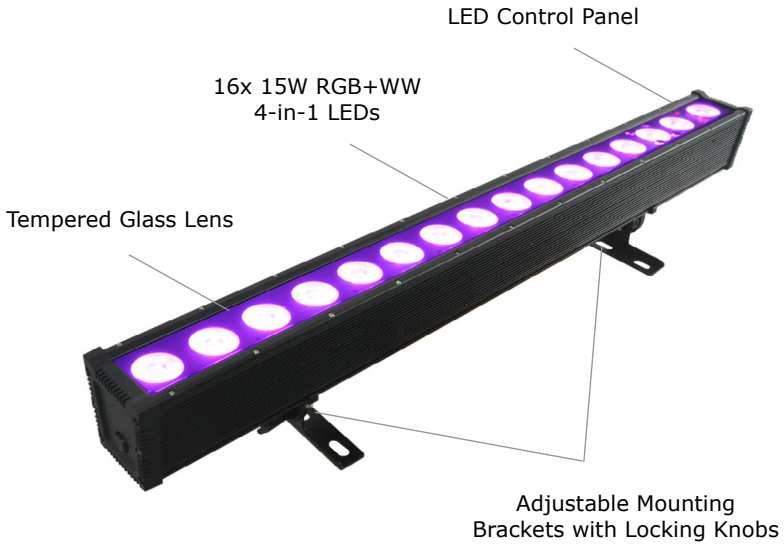
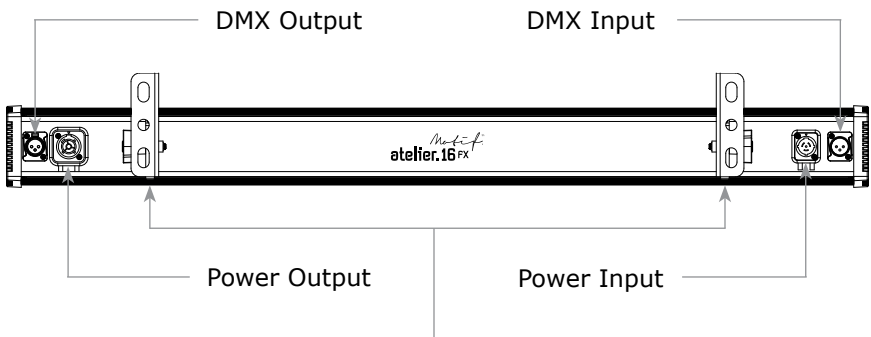

Figure 2: The Rear Connections



Note: For vertical fixture mounting, it is highly recommended to replace the white plastic bracket tightening screws with the included stainless-steel replacement screws for a tighter grip.

3. SETUP



Please read these instructions carefully. They include important information about the installation, usage and maintenance of this product.

Fuse Replacement

CAUTION! The Motif™ Atelier 16FX utilizes a high-output switch-mode power supply with an internal fuse. Under normal operating conditions, the fuse should not require replacement. The fuse is field replaceable, however it is an advanced procedure suited to qualified individuals. Should your Motif™ Atelier 16FX fuse require replacement, please contact Blizzard Lighting for instructions, or to return your unit for service.

Connecting A Bunch of Motif™ Atelier 16FX Fixtures

You will need a serial data link to run light shows using a DMX-512 controller or to run shows on two or more fixtures set to sync in master/slave operating mode. The combined number of channels required by all the fixtures on a serial data link determines the number of fixtures the data link can support.

Fixtures on a serial data link must be daisy chained in one single line. Also, connecting more than 32 fixtures on one serial data link without the use of a DMX optically-isolated splitter may result in deterioration of the digital DMX signal.

The maximum recommended cable-run distance is 500 meters (1640 ft). The maximum recommended number of fixtures on a serial data link is 32 fixtures.

Data/DMX Cabling

To link fixtures together you'll need data cables. You should use data-grade cables that can carry a high quality signal and are less prone to electromagnetic interference.

For instance, Belden© 9841 meets the specifications for EIA RS-485 applications. Standard microphone cables will "probably" be OK, but note that they cannot transmit DMX data as reliably over long distances. In any event, the cable should have the following characteristics:

*2-conductor twisted pair plus a shield
Maximum capacitance between conductors – 30 pF/ft.
Maximum capacitance between conductor & shield – 55 pF/ft.
Maximum resistance of 20 ohms / 1000 ft.
Nominal impedance 100 – 140 ohms*

Cable Connectors

Cables must have a male XLR connector on one end and a female XLR connector on the other end. (Duh!)

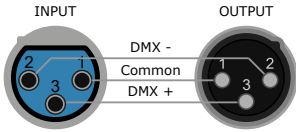

A Word on Termination:

DMX is a resilient communication protocol, however errors still occasionally occur. Termination reduces signal errors, and therefore best practices include use of a terminator in all circumstances. If you are experiencing problems with erratic fixture behavior, especially over long signal cable runs, a terminator may help improve performance.

To build your own DMX Terminator:

Obtain a 120-ohm, 1/4-watt resistor, and wire it between pins 2 & 3 of the last fixture. They are also readily available from specialty retailers.

CAUTION: Do not allow contact between the common and the fixture's chassis ground. Grounding the common can cause a ground loop, and your fixture may perform erratically. Test cables with an ohm meter to verify correct polarity and to make sure the pins are not grounded or shorted to the shield or each other.

3-Pin??? 5-Pin??? Huh?!?

If you use a controller with a 5 pin DMX output connector, you will need to use a 5 pin to 3 pin adapter. They are widely available over the internet and from specialty retailers. If you'd like to build your own, the chart below details a proper cable conversion:

Conductor	3-Pin Female (Output)	5-Pin Male (Input)
Ground/Shield	Pin 1	Pin 1
Data 1- (Primary Data Link)	Pin 2	Pin 2
Data 1+ (Primary Data Link)	Pin 3	Pin 3
Data 2- (Optional Secondary Data Link)	--	Pin 4 - Do Not Use
Data 2+ (Optional Secondary Data Link)	--	Pin 5 - Do Not Use

Take It To The Next Level: Setting Up DMX Control

Step 1: Connect the male connector of the DMX cable to the female connector (output) on the controller.

Step 2: Connect the female connector of the DMX cable to the first fixture's male connector (input).

Note: It doesn't matter which fixture address is the first one connected. We recommend connecting the fixtures in terms of their proximity to the controller, rather than connecting the lowest fixture number first, and so on.

Step 3: Connect other fixtures in the chain from output to input as above. Place a DMX terminator on the output of the final fixture to ensure best communication.

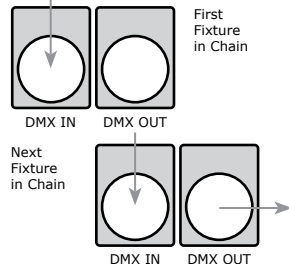

Fixture Linking (Master/Slave Mode)

1. Connect the (male) 3-pin connector side of the DMX cable to the output (female) 3-pin connector of the first fixture.
2. Connect the end of the cable coming from the first fixture which will have a (female) 3-pin connector to the input connector of the next fixture consisting of a (male) 3-pin connector. Then, proceed to connect from the output as stated above to the input of the following fixture and so on.

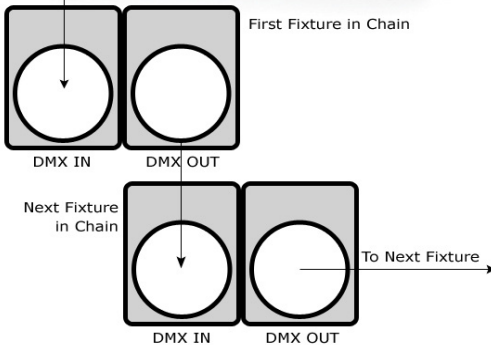

A quick note: Often, the setup for Master-Slave and Standalone operation requires that the first fixture in the chain be initialized for this purpose via either settings in the control panel or DIP-switches. Secondly, the fixtures that follow may also require a slave setting.

Check the “**Operating Adjustments**” section in this manual for complete instructions for this type of setup and configuration.

Mounting & Rigging

NOTE: The mounting brackets on this fixture are adjustable and come equipped with white plastic screws for securing them in place. **For vertical fixture mounting, it is highly recommended to use the included stainless-steel replacement screws for a tighter grip, avoiding possibility of the fixture sliding down.**

This fixture may be mounted in any SAFE position provided there is enough room for ventilation.

Mount the fixture using a suitable “C” or “O” type clamp. The clamp should be rated to hold at least 10x the fixture’s weight to ensure structural stability. Do not mount to surfaces with unknown strength, and ensure properly “rated” rigging is used when mounting fixtures overhead.

Adjust the angle of the fixture by loosening both knobs and tilting the fixture. After finding the desired position, retighten both knobs.

Safety cables **MUST ALWAYS** be used.

4. OPERATING ADJUSTMENTS

The Control Panel

All the goodies and different modes possible with the Motif™ Atelier 16FX are accessed by using the control panel on the rear of the fixture. There are 4 control buttons below the LED display which allow you to navigate through the various control panel menus.

<MENU>

Is used to navigate to the previous higher-level menu item.

<UP>

Scrolls through menu items and numbers in ascending order.

<DOWN>

Scrolls through menu items and numbers in descending order.

<ENTER>

Is used to select and confirm/store the current selection.

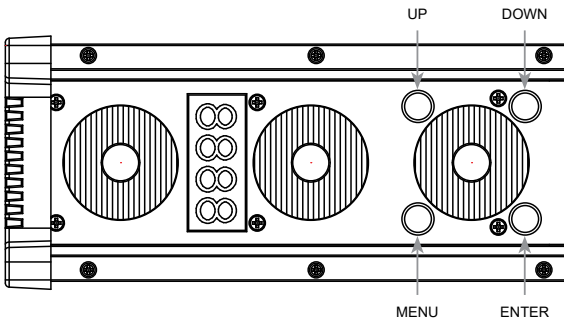

The control panel LED display shows the menu items you select from the menu map on page #11. When a menu function is selected, the display will show immediately the first available option for the selected menu function. To select a menu item, press **<ENTER>**.

Press the **<MENU>** button repeatedly until you reach the desired menu function. Use the **<UP>** and **<DOWN>** buttons to navigate the menu options. Press the **<ENTER>** button to select the menu function currently displayed, or to enable a menu option. To return to the previous option or menu without changing the value, press the **<MENU>** button.

Control Panel Menu Structure

ADDR	001-512		To choose the DMX address				
STAT	R1		Red intensity - Group 1 (0% <--> 100%)				
	G1		Green intensity - Group 1 (0% <--> 100%)				
	B1		Blue intensity - Group 1 (0% <--> 100%)				
	W1		Warm white intensity - Group 1 (0% <--> 100%)				
	R2		Red intensity - Group 2 (0% <--> 100%)				
	G2		Green intensity - Group 2 (0% <--> 100%)				
	B2		Blue intensity - Group 2 (0% <--> 100%)				
	W2		Warm white intensity - Group 2 (0% <--> 100%)				
SHUT		Flash / strobe speed (0-255)					
SET	CAL		To set global intensity levels of each color + USE: YES/NO				
	CHMD	72CH	To run in 72-channel mode				
		64CH	To run in 64-channel mode				
		40CH	To run in 40-channel mode				
		24CH	To run in 24-channel mode				
		16CH	To run in 16-channel mode				
		10CH	To run in 10-channel mode				
		5CH	To run in 5-channel mode				
	4CH	To run in 4-channel mode					
		DIM (dimming)	LIN	Linear dimming curve			
			SQR	Square law curve			
			ISQR	Inverse square law curve			
			SCUR	S-curve			
			LIN.	Linear dimming curve (smooth)			
			SQR.	Square law curve (smooth)			
	ISQR.		Inverse square law curve (smooth)				
	SCUR.		S-curve (smooth)				
	DISY (display)	ON	LED menu display is on continually				
		2MIN	LED menu display shuts off after 2 minutes of inactivity.				
	LOCK	YES/NO	To unlock, press the buttons in this order: <MENU> , <UP> , <DOWN> , <ENTER> 3x times in a row with no longer than 2 seconds between each button press.				
DOT	YES/NO	Enable or disable the DMX signal indicator LED					
CTST	CT01-CT10	<ENTER>	R/G/B/W adjustments for custom color banks 01-10				
AUTO	AT01-AT33	<ENTER>	Auto programs 1-33				
	ATSP (speed)	<ENTER>	Auto Speed				
	CHS1	<ENTER>	Custom program 1				
	CHS2	<ENTER>	Custom program 2				
	CHS3	<ENTER>	Custom program 3				
PROG	CHS1- CHS3 Custom programs 1-3.	SC01- SC20 20 scenes for each custom program.	R1 (0-255)	R2 (0-255)	AUTO (None, AT01-AT05)		
			G1 (0-255)	G2 (0-255)	ATSP (speed, 0-255)		
			B1 (0-255)	B2 (0-255)	TIME (duration, 0-255)		
			W1 (0-255)	W2 (0-255)	WAIT (before fade, 0-255)		
			SHUT (strobe, 0-255)		USE (use scene, YES/NO)		
INFO	SOFT		Software version information				
	TEMP		Current automated overheat protection level (100%/80%/50%)				
	POW		Current temperature (C) of the LED board				
LOAD	ST L		Restore factory settings				
	PR L		Restore factory program settings				
SEND	YES/NO		Sync settings between fixtures via DMX				
ID	0-255		Fixture ID				

DMX Mode

Allows the unit to be controlled by any universal DMX controller.

Setting the DMX Address:

- 1.) The default mode for the fixture is DMX, which appears as **001** on the LED readout. To select a different DMX address, using the **<MENU>** button, select **ADDR**, then hit **<ENTER>**. Use the **<UP/DOWN>** buttons to select the correct address, then hit **<ENTER>** to confirm.

Setting the DMX Channel Mode:

- 1.) To select a DMX channel mode, press the **<MENU>** button, then use the **<UP/DOWN>** buttons until the display reads **SET** and press the **<ENTER>** button. Then use the **<UP/DOWN>** buttons until the display reaches **CHMD**, and press **<ENTER>**. Now press the **<UP/DOWN>** buttons again to highlight your desired DMX channel mode, and press the **<ENTER>** button to confirm.

Slave Mode:

- 1.) Daisy chain the fixtures DMX in/out, having the controller at the beginning of the line.
- 2.) There is nothing else to it! The first fixture in the DMX chain is the master fixture, and the following fixtures will follow the master.

Dimming Mode Settings:

Allows users to set the fixture to use 1 of 4 (x2) dimming curve settings for smoother (and slower) dimming capabilities. In the control panel menu, there are two settings for each curve that are distinguishable from one another by the trailing dot.

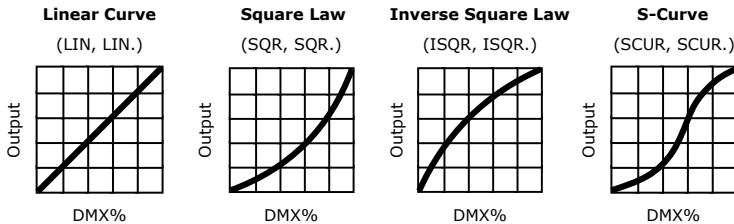

*The curve settings with the trailing dot adds a bit more delay to the curve for a smoother effect.

- 1.) Use the **<MENU>** and **<UP/DOWN>** buttons to navigate to **SET** and press **<ENTER>**, then **<UP/DOWN>** buttons again to scroll to **DIM**, and press the **<ENTER>** button.
- 2.) Now use the **<UP/DOWN>** buttons to highlight either **LIN** (Linear), **SQR** (Square), **ISQR** (Inverse Square), **SCUR** (S-Curve), **LIN.** (Smooth Linear), **SQR.** (Smooth Square), **ISQR.** (Smooth Inverse Square), or **SCUR.** (Smooth S-Curve), then hit **<ENTER>**.

LED Display Setting:

- 1.) Use the **<MENU>** and **<UP/DOWN>** buttons to navigate to **SET** and press **<ENTER>**, then navigate to **DISY** (display). Press the **<ENTER>** button.
- 2.) In **DISY**, you can set the LED menu display to be continually on, or automatically shut off after 2 min of inactivity.

Custom Programs:

Allows users to create up to 3 customizable, 20 scene programs that are directly accessible via the control panel and also in DMX mode.

Creating A Custom Program:

- 1.) Use the <MENU> and <UP/DOWN> buttons to navigate to **PROG**, and press <ENTER>.
- 2.) Now use the <UP/DOWN> buttons to highlight your choice of either **CHS1**, **CHS2**, or **CHS3** and press <ENTER>.
- 3.) Start with editing scene 1 (**SC01**), customizing it to your liking by using the choices outlined in the table below. You can insert any of its 33 built-in auto programs (**AT01-AT33**), and adjust its speed (**ATSP 0-255**), and also set the duration (in seconds) before moving on to the next scene (**TIME 0-255**). Or, you can create a custom scene by color mixing any (or all) of the 3 pixel groups, then add in a fade in effect (**WAIT 0-255**), and/or strobe (**SHUT 0-255**). Finally, if you want to use this scene in your program, *be sure to enable it (USE: YES/NO)*.
- 4.) Repeat the above process to create up to 20 scenes in each of the 3 customizable programs.

R1 / R2 (0-255) - Red Intensity	AUTO (AT01-AT05) - Auto Programs	<i>IMPORTANT:</i> <i>If USE is set to NO, or TIME is set to 0, the scene will not run!</i>
G1 / G2 (0-255) - Green Intensity	ATSP (0-255) - Auto Speed (fast - slow)	
B1 / B2 (0-255) - Blue Intensity	TIME (0-255) - Scene Time (seconds)	
W1 / W2 (0-255) - WW Intensity	WAIT (0-255) - Fade In (fast - slow)	
SHUT (0-255) - Strobe (slow - fast)	USE (YES/NO) Use Scene in Program?	

Running A Custom Program:

- 1.) To view your newly created lighting masterpiece, use the <MENU> and <UP/DOWN> buttons to navigate to **AUTO**, and press <ENTER>.
- 2.) Use the <UP/DOWN> buttons to highlight your choice of either **CHS1**, **CHS2**, or **CHS3** and press <ENTER>. These are also directly accessible from the **Effect Channel** in DMX mode.

Auto Mode and Speed Settings:

Set single or Master/Slaved units to run automated programs at user selectable speeds.

Auto Mode:

- 1.) Use the <MENU> and <UP/DOWN> buttons to navigate to navigate to **AUTO**, and press the <ENTER> button.
- 2.) Now use the <UP/DOWN> buttons to highlight any program ranging from **AT01-AT33**, and press <ENTER>.

Auto Speed:

- 1.) Use the <MENU> and <UP/DOWN> buttons to navigate to **AUTO** and press <ENTER>, then with the <UP/DOWN> buttons navigate to **ATSP**, and press the <ENTER> button.
- 2.) Make a selection from **0-255**, and press <ENTER> to choose a speed (slow <-> fast).

Color Calibration Settings:

Allows the user to setup and save 1 customized R/G/B/WW color balance setting and save it for future use. This custom setting is global, and it will effect all modes.

- 1.) Use the **<MENU>** and **<UP/DOWN>** buttons to navigate to **SET** and press **<ENTER>**, then on while **CAL**, push **<ENTER>** again.
- 2.) Use the **<UP/DOWN>** buttons to highlight either **R** (Red), **G** (Green), **B** (Blue), or **W** (Warm White), then hit **<ENTER>**.
- 3.) Now using the **<UP/DOWN>** buttons, select the maximum level for each color between 000-255 (000=off), and hit **<ENTER>** to confirm your choice.
- 4.) You have now just setup and saved a custom global color calibration setting that you can use at you convenience. To use your custom setting now (or later), press the **<UP/DOWN>** buttons to reach **USE**, and press **<ENTER>**. Then choose either **YES** or **NO** and press **<ENTER>**. When you select **YES**, it enables this custom color calibration globally, and when choosing **NO** the fixture will continue to use the default color calibration settings. Your customized settings will be saved for later use even after powering off the fixture. It can be altered to your liking at any time. Just remember to return to this setting to either enable or disable it when needed.

Custom Static Colors:

Allows the user to create and save up to 10 custom static colors for use in standalone or DMX mode.

- 1.) Use the **<MENU>** and **<UP/DOWN>** buttons to navigate to **CTST** and press **<ENTER>**, then **<UP/DOWN>** buttons to select a color bank from **CT01-CT10**, and push **<ENTER>** to confirm your selection.
- 2.) Now use the **<UP/DOWN>** buttons to highlight either **R** (Red), **G** (Green), **B** (Blue), or **W** (Warm White), then hit **<ENTER>**.
- 3.) Finally, using the **<UP/DOWN>** buttons, select the maximum level for each color between 000-255 (000=off), and hit **<ENTER>** to confirm your choice(s).
- 4.) These 10 custom colors can be accessed and edited to your liking at any time, and will be saved even after powering off the fixture.
- 5.) These static colors are directly accessible from the **Effect Channel** in DMX mode.

Fixture Reset Functions:

Allows users to reset the fixture to factory default settings, without loosing customized settings, or reset the custom programs exclusively.

- 1.) Use the **<MENU>** and **<UP/DOWN>** buttons to navigate to **LOAD** and press **<ENTER>**, then use the **<UP/DOWN>** buttons to highlight **ST L** or **PR L**, and press **<ENTER>**.
- 2.) Use the **<UP/DOWN>** buttons to highlight either **YES** or **NO**, then press **<ENTER>**.
- 3.) The **ST L** reset function will reset all default values *with the exception of* those in **ADDR** (address), **CTST** (10 custom colors), and **PROG** (custom scenes and programs).
- 4.) The **PR L** reset function will only reset all customized program settings found in the **PROG** settings (custom scenes and programs).

Data Sync Feature:

Users can transfer their custom settings from one fixture to another via DMX.

- 1.) Disconnect fixtures from any DMX controllers, and link them together via DMX in/out.
- 2.) On the sending fixture (DMX out), navigate the main menu using the **<UP/DOWN>** buttons to reach **SEND**, and press the **<ENTER>** button.
- 3.) Select **YES**, and press the **<ENTER>** button to begin the transfer.
- 4.) Information for **ADDR** (address), **CAL** (global intensity), or **ID** (Fixture ID) will not be sent.
- 5.) After the data has been transferred, the receiving fixture will be automatically be reset.

Fixture ID Settings:

ID settings give you the ability to assign ID numbers to individual or groups of fixtures for quick and easy DMX control access. This is available in 72/40/24 and 16-channel DMX modes.

- 1.) Use the **<MENU>** and **<UP/DOWN>** buttons to navigate to **ID** and press **<ENTER>**.
- 2.) Now use the **<UP/DOWN>** buttons to select any ID value you would like to assign to this fixture, and press the **<ENTER>** button to save it.
- 3.) While using a DMX channel mode where fixture ID control available, you can now set the **ID Function Slider** to a value ranging from **010-020** for "1 ID control per each 1 digit", ex. 21 = ID21, 22=ID22, or you can set the **ID FUNCTION** slider to a value ranging from **021-030** for "1 ID control per each 10 digit" functionality, ex. 010 <--> 019 = ID1, etc.
- 4.) Now use the **ID Address Slider** on your controller to select the fixture ID number (or ID range) setup in steps 1 & 2, while keeping in mind the function method you selected in step 3.
- 5.) You should now have DMX control of any fixtures with this ID.

Fixture Information:

These are not editable features, they are for informational purposes only.

- 1.) Use the **<MENU>** and **<UP/DOWN>** buttons to navigate to **INFO** and press **<ENTER>**, then use the **<UP/DOWN>** buttons to highlight **SOFT**, **TEMP**, or **POW**, and press **<ENTER>**.
- 2.) The **SOFT** information displays the current software version installed on the fixture, **TEMP** displays the temperature (C) of the LED board, and **POW** displays the fixtures current power level setting. Normally, it will be at 100%... but this fixture has built-in overheat protection that may automatically reduce the output level to 80%, or 50% in high temperature situations.

DMX Value In-Depth Reference Guide

Function	Value	What It Does
Dimmer	000 <--> 255	(0% <--> 100%)
Red Intensity	000 <--> 255	(0% <--> 100%)
Green Intensity	000 <--> 255	(0% <--> 100%)
Blue Intensity	000 <--> 255	(0% <--> 100%)
Warm White Intensity	000 <--> 255	(0% <--> 100%)
Strobe	000 <--> 005 006 <--> 020 021 <--> 060 061 <--> 100 101 <--> 140 141 <--> 180 181 <--> 220 221 <--> 255	No strobe Non-synchronous strobe (slow <--> fast) Synchronous strobe (slow <--> fast) Electronic sine wave (slow <--> fast) Random strobe (slow <--> fast) Opening pulse (slow <--> fast) Closing pulse (slow <--> fast) Electronic square wave (slow <--> fast)
Effect	000 <--> 005 006 <--> 010 011 <--> 015 016 <--> 020 021 <--> 025 026 <--> 030 031 <--> 035 036 <--> 040 041 <--> 045 046 <--> 050 051 <--> 055 056 <--> 060 061 <--> 065 066 <--> 070 071 <--> 075 076 <--> 080 081 <--> 085 086 <--> 090 091 <--> 095 096 <--> 100 101 <--> 105 106 <--> 110 111 <--> 115 116 <--> 120 121 <--> 125 126 <--> 130 131 <--> 135 136 <--> 140 141 <--> 145 146 <--> 150 151 <--> 155 156 <--> 160 161 <--> 165 166 <--> 170 171 <--> 175 176 <--> 180 181 <--> 185 186 <--> 190 191 <--> 195 196 <--> 200 201 <--> 205 206 <--> 210 211 <--> 215 216 <--> 220 221 <--> 225 226 <--> 230 231 <--> 235 236 <--> 255	No Function Custom color 1 (CT01 in menu settings) Custom color 2 (CT02 in menu settings) Custom color 3 (CT03 in menu settings) Custom color 4 (CT04 in menu settings) Custom color 5 (CT05 in menu settings) Custom color 6 (CT06 in menu settings) Custom color 7 (CT07 in menu settings) Custom color 8 (CT08 in menu settings) Custom color 9 (CT09 in menu settings) Custom color 10 (CT10 in menu settings) Auto 1 - R, G, B, W, RG, RB, GB, RGBW Auto 2 - R↑, R↓, G↑, G↓, B↑, B↓, W↑, W↓ Auto 3 - R↑G↑, R↓G↓, R↑B↑, R↓B↓, B↑G↑, B↓G↓ Auto 4 - R↑G↑B↑W↑, R↓G↓B↓W↓ Auto 5 - B, BG↑, BG, B↓G, G, GR↑, GR, G↓R, R, RB↑, RB, R↓B Auto 6 - 1 to 16 pixel chase, then color change Auto 7 - RGBY step running Auto 8 - 4Y running with fade Auto 9 - 4P step running Auto 10 - 4R running on G Auto 11 - 4G running on B Auto 12 - 4Y running on P Auto 13 - 4R step running Auto 14 - 4C step running Auto 15 - 6Y running with fade Auto 16 - 6P running with fade Auto 17 - Y open from 1-16 then dark Auto 18 - B open from 1-16 then dark Auto 19 - Each piece change with RGBYPC Auto 20 - Inverse direction of AUTO 6 Auto 21 - Inverse direction AUTO 7 Auto 22 - 4P running with fade Auto 23 - Inverse direction AUTO 9 Auto 24 - Inverse direction AUTO 10 Auto 25 - Inverse direction AUTO 11 Auto 26 - Inverse direction AUTO 12 Auto 27 - Inverse direction AUTO 13 Auto 28 - Inverse direction AUTO 14 Auto 29 - 4R running with fade Auto 30 - 4B running with fade Auto 31 - Inverse direction AUTO 17 Auto 32 - Inverse direction AUTO 18 Auto 33 - Each piece rainbow effect Custom program 1 (CH01 in menu settings) Custom program 2 (CH02 in menu settings) Custom program 3 (CH03 in menu settings) No Function

DMX Value In-Depth Reference Guide (continued)

Function	Value	What It Does
Auto Speed	000 <--> 255	(fast <--> slow)
Virtual Color Wheel	000 <--> 010 011 012 <--> 050 051 052 <--> 090 091 092 <--> 130 131 132 <--> 170 171 172 <--> 210 211 212 <--> 250 251 <--> 255	No Function Blue Blue (+ green) Teal Teal (- blue) Green Green (+ red) Yellow Yellow (- green) Red Red (+ blue) Magenta Magenta (- red) Blue
Dimming Mode	000 <--> 010 011 <--> 020 021 <--> 030 031 <--> 040 041 <--> 050 051 <--> 060 061 <--> 070 071 <--> 080 081 <--> 090 091 <--> 255	Default (as set in the LED menu) Linear curve Square law curve Inverse square law curve S-curve Linear curve (smooth) Square law curve (smooth) Inverse square law curve (smooth) S-curve (smooth) Default (as set in the LED menu)
ID Function	000 <--> 010 010 <--> 020 021 <--> 030 031 <--> 255	No Function 1 ID per each 1, ex. 210 = ID21, 211=ID22 1 ID per each 10, ex. 010 <--> 019 = ID1 No function
ID Address	000 <--> 255	Control fixture(s) ID number 0-255

LED Pixel Group Configurations

Below are illustrations of the fixtures 5 different pixel group configurations.

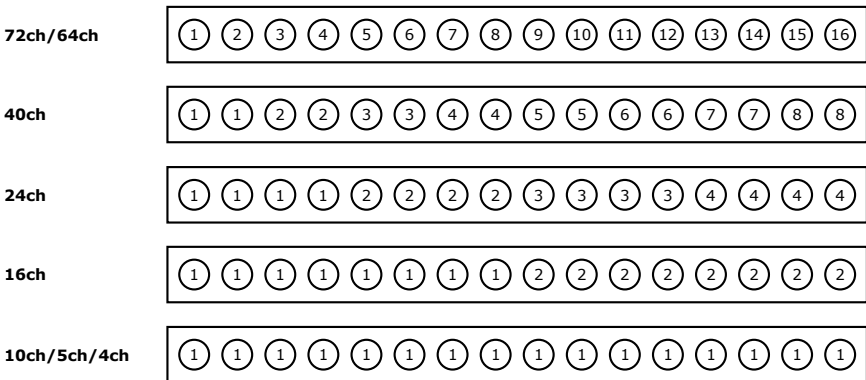

DMX In-Depth Reference: 72-Channel Mode

Ch.	Name	Ch.	Name	Ch.	Name	Ch.	Name
1	Dimmer	19	Green 5	37	Warm White 9	55	Green 14
2	Red 1	20	Blue 5	38	Red 10	56	Blue 14
3	Green 1	21	Warm White 5	39	Green 10	57	Warm White 14
4	Blue 1	22	Red 6	40	Blue 10	58	Red 15
5	Warm White 1	23	Green 6	41	Warm White 10	59	Green 15
6	Red 2	24	Blue 6	42	Red 11	60	Blue 15
7	Green 2	25	Warm White 6	43	Green 11	61	Warm White 15
8	Blue 2	26	Red 7	44	Blue 11	62	Red 16
9	Warm White 2	27	Green 7	45	Warm White 11	63	Green 16
10	Red 3	28	Blue 7	46	Red 12	64	Blue 16
11	Green 3	29	Warm White 7	47	Green 12	65	Warm White 16
12	Blue 3	30	Red 8	48	Blue 12	66	Strobe
13	Warm White 3	31	Green 8	49	Warm White 12	67	Effect
14	Red 4	32	Blue 8	50	Red 13	68	Speed
15	Green 4	33	Warm White 8	51	Green 13	69	Virtual Color Wheel
16	Blue 4	34	Red 9	52	Blue 13	70	Dimming Mode
17	Warm White 4	35	Green 9	53	Warm White 13	71	ID Function
18	Red 5	36	Blue 9	54	Red 14	72	ID Address

DMX In-Depth Reference: 64-Channel Mode

Ch.	Name	Ch.	Name	Ch.	Name	Ch.	Name
1	Red 1	17	Red 5	33	Red 9	49	Red 13
2	Green 1	18	Green 5	34	Green 9	50	Green 13
3	Blue 1	19	Blue 5	35	Blue 9	51	Blue 13
4	Warm White 1	20	Warm White 5	36	Warm White 9	52	Warm White 13
5	Red 2	21	Red 6	37	Red 10	53	Red 14
6	Green 2	22	Green 6	38	Green 10	54	Green 14
7	Blue 2	23	Blue 6	39	Blue 10	55	Blue 14
8	Warm White 2	24	Warm White 6	40	Warm White 10	56	Warm White 14
9	Red 3	25	Red 7	41	Red 11	57	Red 15
10	Green 3	26	Green 7	42	Green 11	58	Green 15
11	Blue 3	27	Blue 7	43	Blue 11	59	Blue 15
12	Warm White 3	28	Warm White 7	44	Warm White 11	60	Warm White 15
13	Red 4	29	Red 8	45	Red 12	61	Red 16
14	Green 4	30	Green 8	46	Green 12	62	Green 16
15	Blue 4	31	Blue 8	47	Blue 12	63	Blue 16
16	Warm White 4	32	Warm White 8	48	Warm White 12	64	Warm White 16

DMX In-Depth Reference: 40-Channel Mode

Ch.	Name	Ch.	Name	Ch.	Name	Ch.	Name
1	Dimmer	11	Green 3	21	Warm White 5	31	Green 8
2	Red 1	12	Blue 3	22	Red 6	32	Blue 8
3	Green 1	13	Warm White 3	23	Green 6	33	Warm White 8
4	Blue 1	14	Red 4	24	Blue 6	34	Strobe
5	Warm White 1	15	Green 4	25	Warm White 6	35	Effect
6	Red 2	16	Blue 4	26	Red 7	36	Speed
7	Green 2	17	Warm White 4	27	Green 7	37	Virtual Color Wheel
8	Blue 2	18	Red 5	28	Blue 7	38	Dimming Mode
9	Warm White 2	19	Green 5	29	Warm White 7	39	ID Function
10	Red 3	20	Blue 5	30	Red 8	40	ID Address

DMX In-Depth Reference: 24-Channel Mode

Ch.	Name	Ch.	Name	Ch.	Name	Ch.	Name
1	Dimmer	7	Green 2	13	Warm White 3	19	Effect
2	Red 1	8	Blue 2	14	Red 4	20	Speed
3	Green 1	9	Warm White 2	15	Green 4	21	Virtual Color Wheel
4	Blue 1	10	Red 3	16	Blue 4	22	Dimming Mode
5	Warm White 1	11	Green 3	17	Warm White 4	23	ID Function
6	Red 2	12	Blue 3	18	Strobe	24	ID Address

DMX In-Depth Reference: 10-Channel Mode

Ch.	Name	Ch.	Name	Ch.	Name	Ch.	Name
1	Dimmer	4	Blue 1	7	Effect	10	Dimming Mode
2	Red 1	5	Warm White 1	8	Speed		
3	Green 1	6	Strobe	9	Virtual Color Wheel		

DMX In-Depth Reference: 5-Channel Mode

Ch.	Name	Ch.	Name	Ch.	Name
1	Dimmer	3	Green 1	5	White 1
2	Red 1	4	Blue 1		

DMX In-Depth Reference: 4-Channel Mode

Ch.	Name	Ch.	Name
1	Red 1	3	Blue 1
2	Green 1	4	Warm White 1

5. APPENDIX

A Quick Lesson On DMX

DMX (aka DMX-512) was created in 1986 by the United States Institute for Theatre Technology (USITT) as a standardized method for connecting lighting consoles to lighting dimmer modules. It was revised in 1990 and again in 2000 to allow more flexibility. The Entertainment Services and Technology Association (ESTA) has since assumed control over the DMX512 standard. It has also been approved and recognized for ANSI standard classification.

DMX covers (and is an abbreviation for) Digital MultipleXed signals. It is the most common communications standard used by lighting and related stage equipment.

DMX provides up to 512 control "channels" per data link. Each of these channels was originally intended to control lamp dimmer levels. You can think of it as 512 faders on a lighting console, connected to 512 light bulbs. Each slider's position is sent over the data link as an 8-bit number having a value between 0 and 255. The value 0 corresponds to the light bulb being completely off while 255 corresponds to the light bulb being fully on.

DMX data is transmitted at 250,000 bits per second using the RS-485 transmission standard over two wires. As with microphone cables, a grounded cable shield is used to prevent interference with other signals.

There are five pins on a DMX connector: a wire for ground (cable shield), two wires for "Primary" communication which goes from a DMX source to a DMX receiver, and two wires for a "Secondary" communication which goes from a DMX receiver back to a DMX source. Generally, the "Secondary" channel is not used so data flows only from sources to receivers. Hence, most of us are most familiar with DMX-512 as being employer over typical 3-pin "mic cables," although this does not conform to the defined standard.

DMX is connected using a daisy-chain configuration where the source connects to the input of the first device, the output of the first device connects to the input of the next device, and so on. The standard allows for up to 32 devices on a single DMX link.

Troubleshooting

Symptom	Solution
Fixture Auto-Shut Off	If it is stopped or running slower than normal, the unit may have shut itself off due to high heat. This is to protect the fixture from overheating.
No Light Output	Check to ensure fixture is operating under correct mode, IE auto/DMX/Etc., if applicable.
Chase Speed Too Fast/Slow	Check to ensure proper setup of speed adjustment.
No Power	Check AC cord and circuit for malfunction.
Fixture Not Responding / Responding Erratically	Make sure all connectors are seated properly and securely. Use Only DMX Cables and/or check cables for defects Install a Terminator. Reset fixture(s).

Keeping Your Motif™ Atelier 16FX As Good As New

The fixture you've received is a rugged, tough piece of pro lighting equipment, and as long as you take care of it, it will take care of you. That said, like anything, you'll need to take care of it if you want it to operate as designed. You should absolutely keep the fixture clean, especially if you are using it in an environment with a lot of dust, fog, haze, wild animals, wild teenagers or spilled drinks.

Cleaning the optics routinely with a suitable glass cleaner will greatly improve the quality of light output. Keeping the fans free of dust and debris will keep the fixture running cool and prevent damage from overheating.

In transit, keep the fixtures in cases. You wouldn't throw a prized guitar, drumset, or other piece of expensive gear into a gear trailer without a case, and similarly, you shouldn't even think about doing it with your shiny new light fixtures.

Common sense and taking care of your fixtures will be the single biggest thing you can do to keep them running at peak performance and let you worry about designing a great light show, putting on a great concert, or maximizing your client's satisfaction and "wow factor." That's what it's all about, after all!

Returns (Gasp!)

We've taken a lot of precautions to make sure you never even have to worry about sending a defective unit back, or sending a unit in for service. But, like any complex piece of equipment designed and built by humans, once in a while, something doesn't go as planned. If you find yourself with a fixture that isn't behaving like a good little fixture should, you'll need to obtain a Return Authorization (RA).

Don't worry, this is easy. Just send an email to support@blizzardpro.com, and we'll issue you an RA. Then, you'll need to send the unit to us using a trackable, pre-paid freight method. We suggest using USPS Priority or UPS. Make sure you carefully pack the fixture for transit, and whenever possible, use the original box & packing for shipping.

When returning your fixture for service, be sure to include the following:

- 1.) Your contact information (Name, Address, Phone Number, Email address).
- 2.) The RA# issued to you
- 3.) A brief description of the problem/symptoms.

We will, at our discretion, repair or replace the fixture. Please remember that any shipping damage which occurs in transit to us is the customer's responsibility, so pack it well!

Shipping Issues

Damage incurred in shipping is the responsibility of the shipper, and must be reported to the carrier immediately upon receipt of the items. Claims must be made within seven (7) days of receipt.

Tech Specs!

Weight & Dimensions	
Width	39.3 inches (997 mm)
Depth	Fixture: 3.7" (94.5 mm), Bracket: 5.2" (132.3 mm)
Height	7.1" (179.9 mm)
Weight	15.4 lbs (7 kg)
Power	
Operating Voltage	100-264VAC, 47-63 Hertz
Power Consumption	214W, 1.8A, PF: .99
Light Source	
LED	16x 15W RGB+WW 4-in-1 LEDs, (2700k Warm White)
Optical	
Beam Angle	10-40° asymmetrical degree beam
Thermal	
Max. Operating Temp.	104 degrees F (40 degrees C) ambient
Control	
Protocol	USITT DMX-512
DMX Channels	4/5/10/16/24/40 or 72-channels
Input/Output	3-pin XLR Male/Female
Operating Modes	Standalone, Master/Slave, Color Preset
Warranty	2-year limited warranty, does not cover malfunction caused by damage to LEDs.

Photometric Data

40° Beam Angle

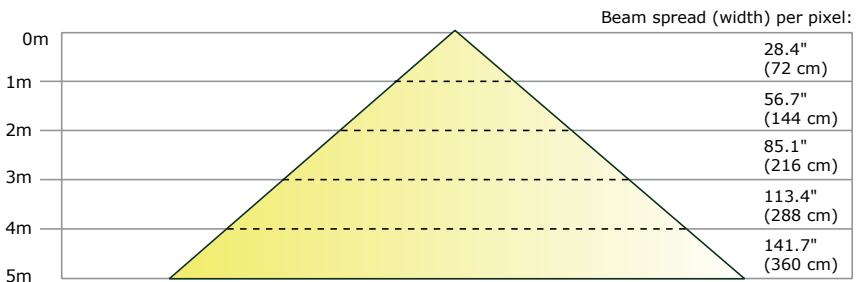

Luminous Intensity:

Beam	2-meter		3-meter		4-meter		5-meter	
	Lux	fc	Lux	fc	Lux	fc	Lux	fc
40°	4,358	404.9	2,134	198.3	1,021	94.9	787	73.2

Motif[™].

we sincerely appreciate
you choosing our products
so, from all of us

thank you.

everything in this manual is copyright 2018 blizzard lighting, llc.
motif, *atelier,* and *blizzard,* are TM and/or (R) blizzard lighting, llc
trees are beautiful and finite.
please recycle this manual if you aren't going to bother reading it :)