

# *ProFan*<sup>TM</sup>

## Operation Manual



## Table of Contents

1. BEFORE YOU BEGIN.....	3
ProFan Overview.....	3
Unpacking Instructions.....	3
2. ASSEMBLY.....	5
Attaching the Yoke Assembly.....	6
3. MOUNTING OPTIONS.....	6
Floor Mounting.....	6
Support Stand.....	6
Overhead Rigging.....	7
4. REMOTE CONTROL.....	8
Basics of DMX Control.....	8
DMX Data Cable.....	8
Cable Connectors.....	9
3-Pin to 5-Pin Conversion Chart.....	9
5. OPERATING INSTRUCTIONS.....	10
BackPack Overview.....	10
Connecting the BackPack Controller.....	10
Attaching the BackPack to the Fan Housing.....	11
DMX Mode.....	12
Manual Mode.....	13
Manual Master/Slave Operation.....	14
Using ProFan with a Smoke Machine.....	15
6. TROUBLESHOOTING AND MAINTENANCE.....	16
Troubleshooting.....	16
Cleaning.....	16
Replacing the Fuse.....	16
7. SAFETY INSTRUCTIONS.....	17
Preventing Fire and Electric Shock.....	17
Preventing Injuries.....	17
8. APPENDIX.....	18
Limited Warranty.....	18
Technical Specifications.....	19

© Copyright 2021, TMB All rights reserved

TMB authorizes its customers to download and print this electronically published manual for professional use only. TMB prohibits reproduction, modification, or distribution of this document for any other purposes, without express written consent.

Specifications are subject to change without notice. The information in this document supersedes all previously supplied information before the effective date listed above. TMB has confidence in the accuracy of the document information herein but assumes no responsibility or liability for any loss occurring as a direct or indirect result of errors or exclusions whether by accident or any other cause.

# 1. BEFORE YOU BEGIN

## ProFan Overview

ProFan is a powerful and versatile DMX-controlled professional fan designed for a variety of applications: Studios, theatres, theme parks, touring, photographic, and more. ProFan is perfect for filling large areas with smoke and haze; creating special wind effects; blowing confetti, snow or bubbles; general air circulation, ventilation, and ambient cooling.

ProFan's combination of deep-pitch 11" blades, spiral grille, and focused-air duct creates a powerful vortex. Multiple ProFans can also be slaved together to increase air flow or to achieve multiple vortex patterns for special effects.

ProFan operates from 100 to 240VAC. It can be floor-mounted, stand-mounted, or suspended from truss or other suitable supports (using ProBurger® accessory clamps or couplers). The external Backpack controller allows DMX or manual control, and master/slave control of multiple ProFans. The molded polymer venting duct and tubular steel housing make the compact ProFan lightweight and rugged. ProFan – the versatile vortex machine!

## Unpacking Instructions

Immediately upon receiving the fixture, carefully unpack the carton and check the contents to ensure that all parts are present (see pages 4-5) and have been received in good condition. Notify the shipper immediately and retain packing material if any parts appear damaged from shipping or the carton itself shows signs of mishandling.



Back Panel Detail

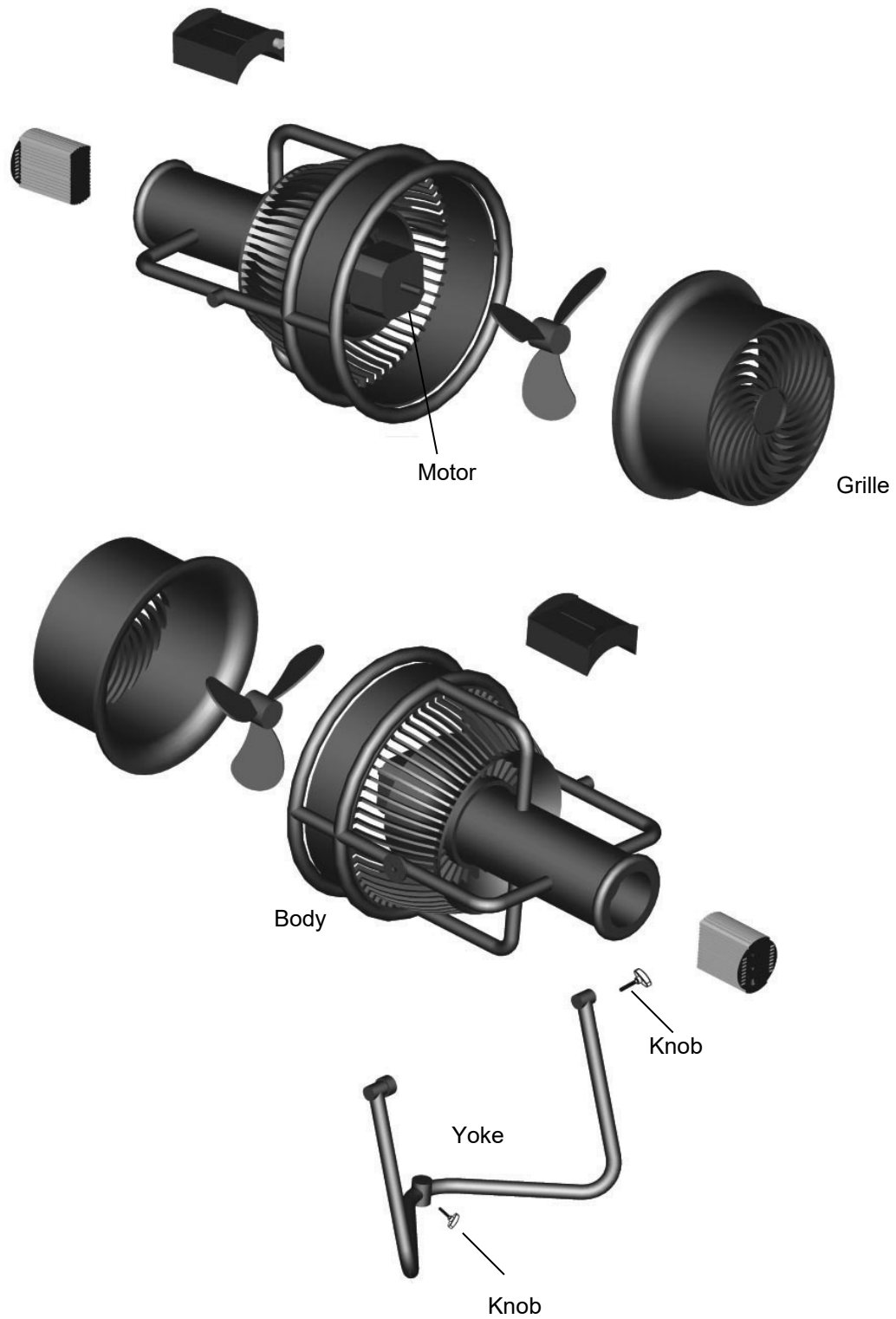

## 2. ASSEMBLY

Included with the ProFan is a multipurpose yoke assembly for standing on the floor or mating the unit to a stand or suspension clamp. The yoke assembly easily attaches to the ProFan using the hardware and wrench included with each ProFan unit

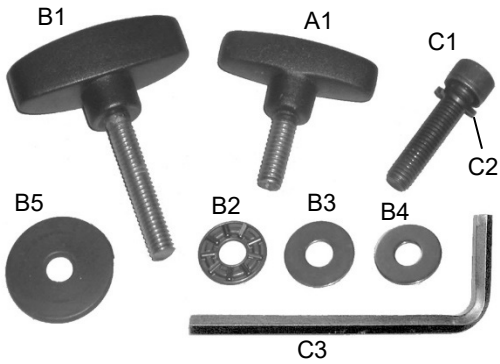

A1	Small head, short shank, T-Handle Knob
B1	Large Head, long shank, T-Handle Knob (swivel lock)
B2	Thrust Washer
B3	Flat Washer
B4	Flat Washer
B5	Aluminum Bushing
C1	Allen Bolt
C2	Split Washer
C3	Allen Wrench

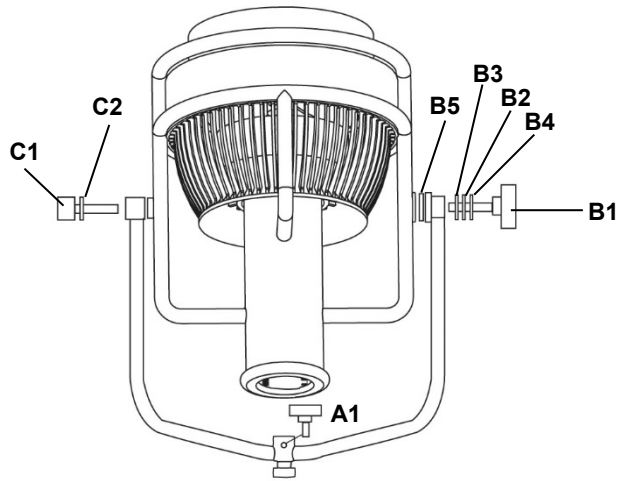

See assembly instructions (page 6)

## Attaching the Yoke Assembly

1. Place the ProFan face down upon its front grille with the hinge barrel side on the left and the hinge flat side on the right.
2. Place Item B3 flat washer upon the shank of Item B1 T-Handle, followed by Item B2 thrust washer and Item B4 flat washer.
3. Place the yoke bracket into position. Insert the shank of Item B1 T-Handle through the flat face hinge until the shank just protrudes from the flat face.
4. Insert Item B5 aluminum bushing between the ProFan housing's tubular bracket and the yoke assembly hinge's flat face.
5. Rotate the T-Handle clockwise until the T-Handle has threaded into the ProFan tubular housing bracket. Do not tighten completely at this point.
6. Place Item C2 split washer onto Item C1 Allen bolt. Place the Allen bolt through the barrel portion of the ProFan hinge and rotate the bolt until it threads into place.
7. Tighten the Allen bolt and the T-Handle until the yoke assembly is fixed and not easily moved.
8. At this point the ProFan is ready for mating with a stand or clamp. Grip the fan by its tubular housing brackets when lifting or mounting to avoid pinching hands or fingers.

## 3. MOUNTING OPTIONS

### Floor Mounting

The ProFan yoke assembly also acts as a stand which rests firmly on the floor, allowing the ProFan to swivel vertically into position as needed.

### Support Stand

Always use a professional stand rated to support weight greater than the ProFan weight (12.5 kg / 27.6 lb). The ProFan yoke is equipped with a TVMP spigot that can fit into a 1-1/8" "Junior" receiver or accept a 5/8" "Baby" spigot (see image on page 7).

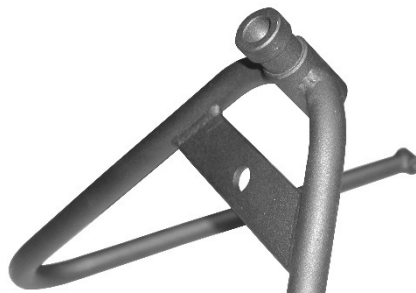

*ProFan yoke spigot and rigging crossbar*

## Overhead Rigging

Proper rigging clamps may be attached to the ProFan yoke via the 9/16" bolt hole located on the crossbar at the base of the yoke.

Recommended ProBurger rigging clamps:

1. PRBHC3/8 or PRBHC1/2 Half Couplers
2. PRBSNC1/2 Snap Coupler.

Make sure that any structure used to support the unit can support at least 10 times the total weight of all installed fixtures, clamps, auxiliary equipment, etc.

1. Check that all rigging clamps are undamaged and can support at least 10 times the weight of the unit (27.6 lbs/12.5 kg x 10).
2. Clamp the fan to truss or similar support.
3. Loosen the swivel locks and tilt the fan to the desired angle. Turn the swivel locks clockwise to tighten. Make sure that fan, hardware, and safety attachment are secure before applying power.

*ProFan yoke with ProBurger Half Coupler attached*

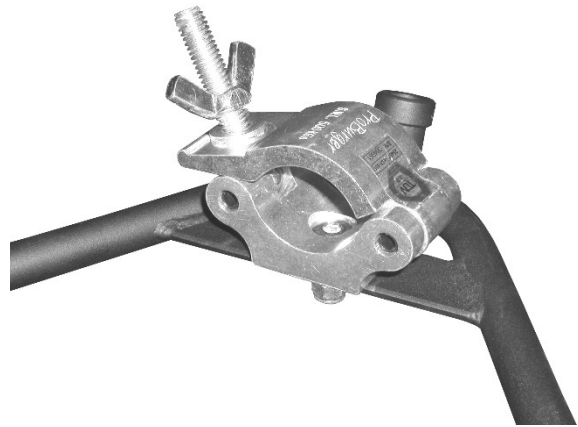

## 4. REMOTE CONTROL

### Basics of DMX Control

There are 512 channels in a DMX-512 universe. Channels may be assigned in any manner. Any device capable of receiving DMX-512 will require one or a number of sequential channels. The user must assign a starting address on the fixture that indicates the first channel reserved in the lighting console. There are many different types of DMX controllable fixtures and they all may vary in the total number of channels required. Choosing a start address should be planned in advance. Channels should never overlap. If they do, this will result in erratic operation of the fixtures whose starting addresses are set incorrectly. You can however, control multiple fixtures of the same type using the same starting address as long as the intended result is that of unison movement or operation. In other words, the fixtures will be slaved together and all will respond in the same way.

DMX fixtures are often designed to receive and transmit data through a DMX daisy-chain. A DMX daisy-chain is where the DMX THRU of one fixture connects to the DMX IN of the next fixture. The order in which the fixtures are connected is not important and has no effect on how a lighting console communicates to each fixture. Use an order that provides for the easiest and most direct cabling. Connect fixtures using shielded two-conductor twisted pair cable with 5-pin XLR male to female connectors. The shield/ground is pin 1, while pin 2 is Data Negative (D-) and pin 3 is Data positive (D+). Pins 4 and 5 are not used according to the DMX-512 standard.

### DMX Data Cable

Use a ProPlex® PC222P, PC224P, or equivalent cable which meets the specifications for EIA RS-485 applications. Standard microphone cables cannot transmit DMX data reliably over long distances. The cable should have the following characteristics:

*Minimum 2-conductor twisted pair plus a shield*

*Maximum capacitance between conductors - 22 pF/ft.*

*Maximum capacitance between conductor and shield - 41 pF/ft.*

*Maximum resistance of 14.5 ohms / 1000 ft.*

*Characteristic impedance of 80 - 110 ohms*

## Cable Connectors

Data cabling must have a male 5-pin XLR connector on one end and a female 5-pin XLR connector on the other end.

### DMX connector configuration

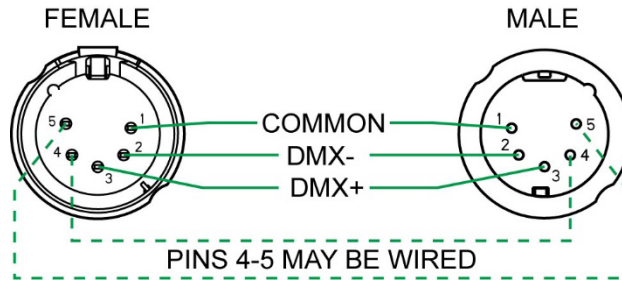

The maximum recommended DMX data link distance between fixtures is 300 meters (984 ft.)

**CAUTION:** In order to prevent the corruption of DMX data, do not allow contact between the common (pin 1) of a DMX cable and the fixture's chassis ground. Grounding the common can cause a ground loop, causing erratic performance.

Test cables and terminators with a continuity tester to verify correct polarity and to make sure the pins are not grounded or shorted to the shield or each other.

### 3-Pin to 5-Pin Conversion Chart

If you use a console with a 3-pin DMX output connector, you will need to use a 3-pin to 5-pin adapter. The chart below details a proper conversion:

3-Pin Male (Input)	5-Pin Male (Output)	Purpose
Pin 1	Pin 1	Ground / Shield
Pin 2	Pin 2	Data ( - ) signal
Pin 3	Pin 3	Data ( + ) signal
	Pin 4	Not Used
	Pin 5	Not Used

## 5. OPERATING INSTRUCTIONS

### BackPack Overview

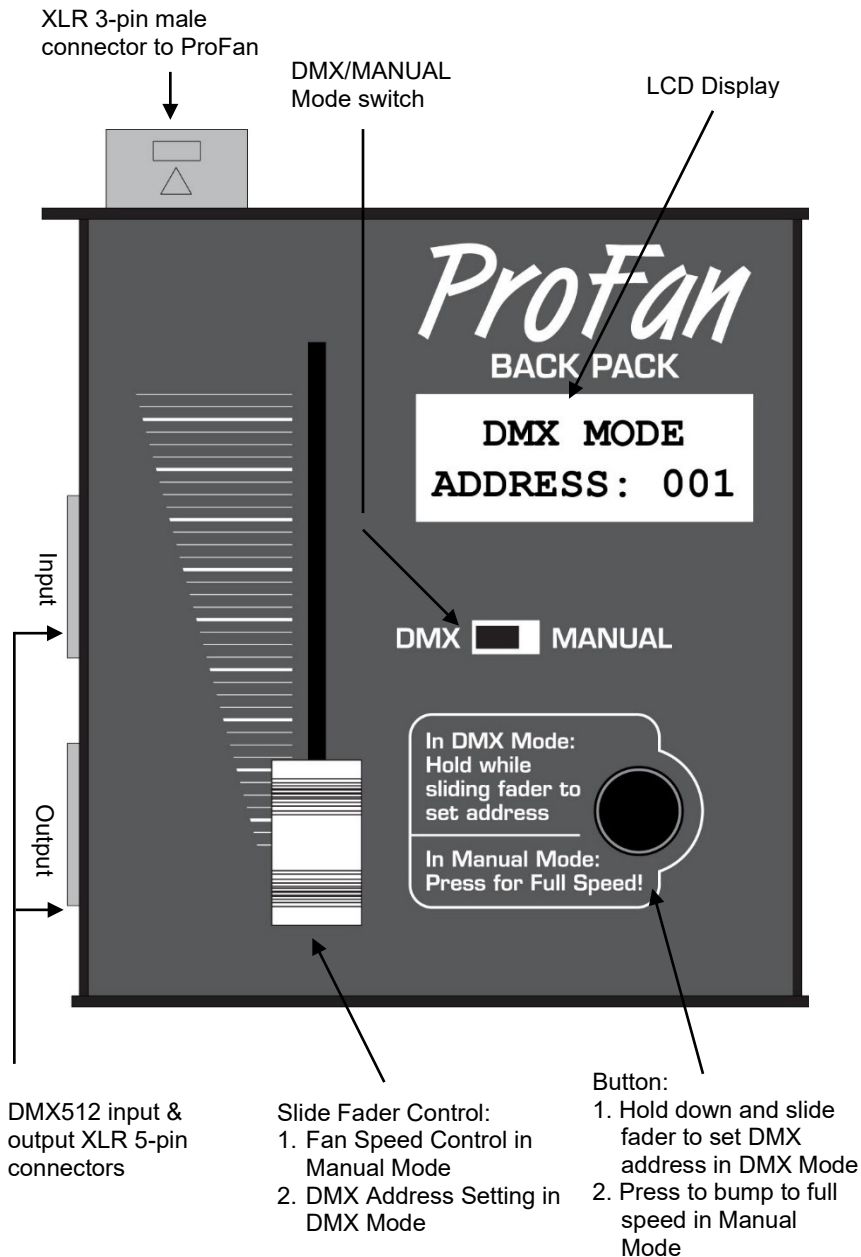

### Connecting the Backpack Controller

With rear Power switch in OFF position:

Connect the integral male XLR on the Backpack directly to the integral female XLR on the fan body. If desired, the Backpack can be removed and connected using a standard 3-pin XLR microphone cable up to 60 ft / 20 m in length.

## Attaching the Backpack to the Fan Housing



The Backpack is secured to the fan housing by: 1) two snap-in clips; 2) an internal magnet; 3) the XLR connection.

Prior to connecting the Backpack to the integral female XLR on the fan body, note that two flat slots exist on the top and bottom of the Backpack housing. These flat slots mate with the mounting bracket fixed to the top of the fan housing.

Place the Backpack with the sliding fader to the left. Push the Backpack forward to mate with the integral female XLR while gently pressing the Backpack against the fan body. While inserting the Backpack onto the integral female XLR, ensure it aligns with the slot in top face of the Backpack. Once fully connected to the integral female XLR, the bottom edge of the mounting bracket will snap into place fixing the bottom of the Backpack by locating into the bottom housing slot.

**CAUTION:** Double-check that the Backpack is securely fixed to the fan housing prior to use.

**Note:** Ensure the ProFan is pointed in a direction where considerable wind will not cause a disturbance or any safety issues.

Turn ProFan ON using the rear Power switch.

## DMX Mode

When the recessed switch on the BackPack is switched to "DMX", the display will indicate that the unit is in DMX Mode and will display the current address of the ProFan. If no incoming DMX signal is detected, the display will then read "No DMX Found".

To adjust the DMX address of the unit, press and hold the Full Speed button while adjusting the fader. With the fader at minimum, the address will be 1. With the fader at maximum, the address will change to 512. Adjusting the fader between min. and max. will change the address between 1 and 512. To store the new address, simply release the button.

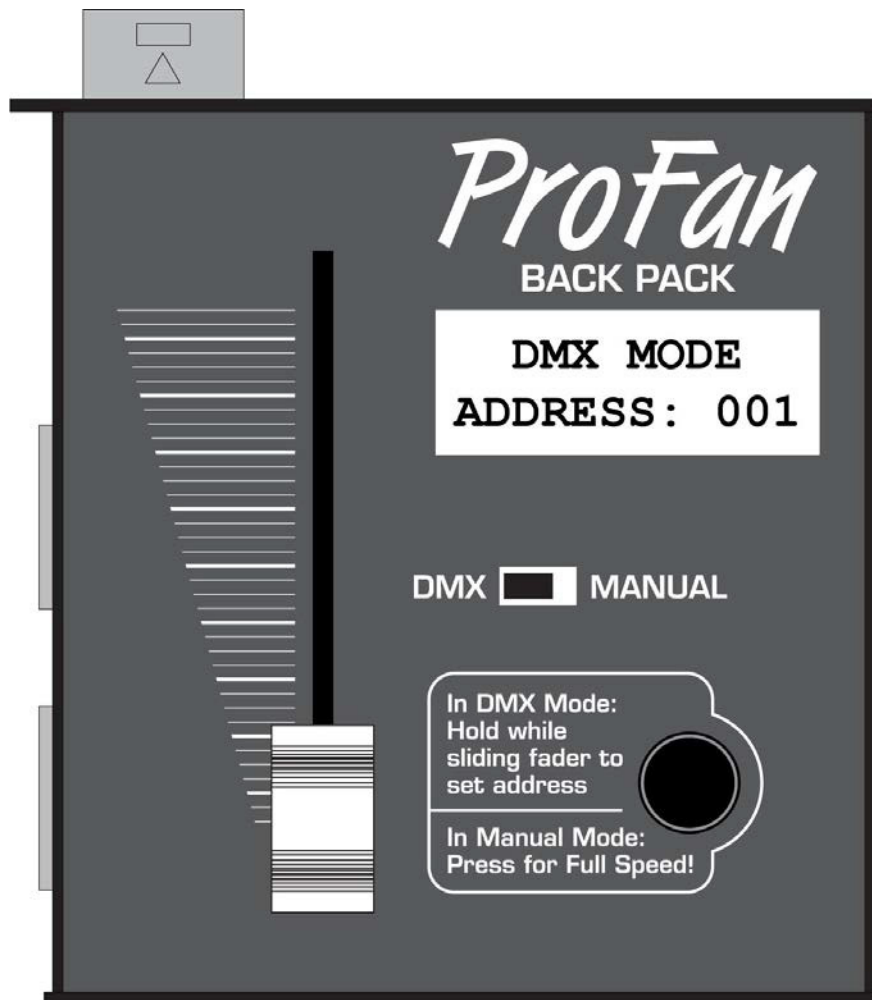

## Manual Mode

When the recessed switch on the BackPack is switched to "MANUAL", the display will indicate that the unit is in Manual Mode. The display will also indicate the current speed of the fan, based on the position of the fader and whether the Full Speed button is depressed.

In this mode, a BackPack controller also acts as a master controller for up to nine ProFans slaved to it via the DMX OUT connector. See Master/Slave Operation (page 16) for details.

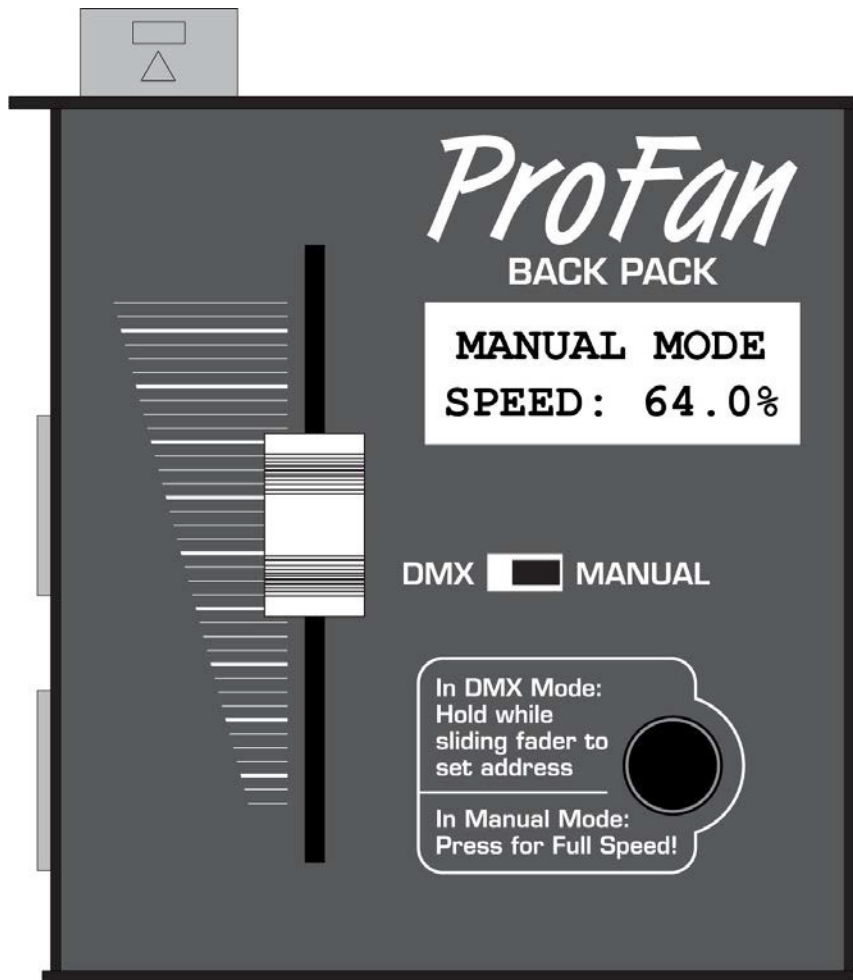

## Manual Master/Slave Operation

Up to nine ProFans can be controlled by a single Back Pack using a DMX data link. To link multiple ProFans, use 5-pin XLR DMX cables to link one ProFan to another.

- 1) Connect each controller to each fan via the built-in XLR 3-pin line female connector.
- 2) Use 5-pin XLR DMX cables to connect the master ProFan output (female XLR) to the next "slave" ProFan input (male XLR).
- 3) Daisy-chain ProFans (up to nine), output-to-input as needed,
- 4) Set the mode switch of the master controller to "MANUAL"; set all the slave controllers to "DMX" at address 001.

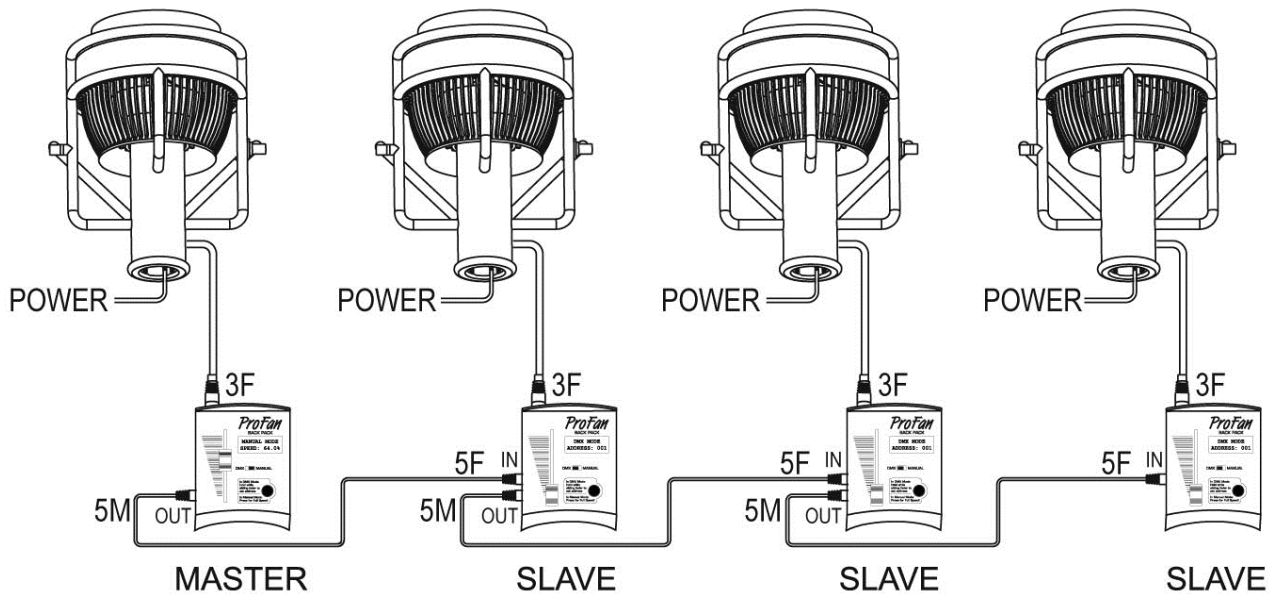

## Using ProFan with a Smoke Machine

When using ProFan with smoke, fog or hazer machines, place the fan behind the machines as illustrated below. Do not place the fan in front of the machine. This will cause residue build-up on the fan blades and degrade the quality of the smoke, fog, or haze.



Incorrect ProFan placement  
in front of fogger/hazer

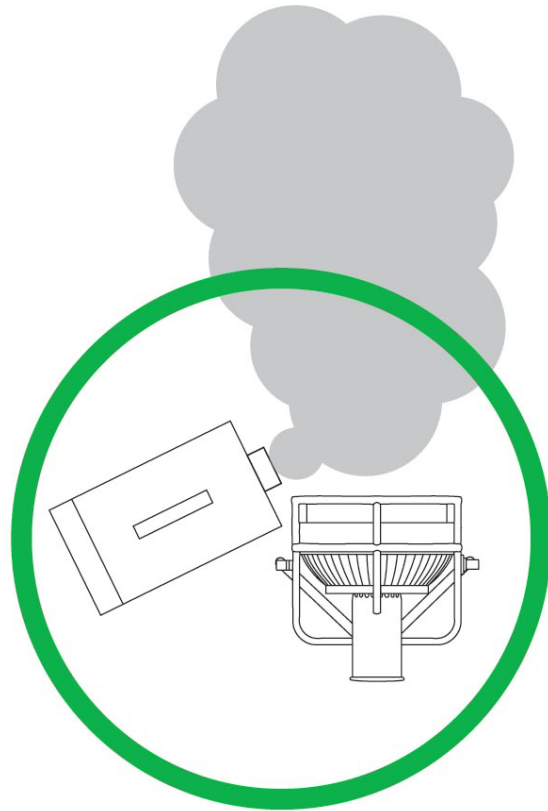

Correct ProFan placement  
behind or to the side of  
fogger/hazer

## 6. TROUBLESHOOTING AND MAINTENANCE

### Troubleshooting

Problem	Symptom/Cause	Suggested Remedy
Power is supplied, but fan does not operate via DMX	Display says "No DMX Found"	Connect DMX
	Incorrect DMX address	Press button and move fader until correct address appears
	In Manual Mode	Switch control switch to DMX mode
BackPack display is blank	No Power	Check power supply and connection
	Fuse blown	Replace fuse with one of same type and rating
	BackPack not connected	Check connection
Reduced airflow	Low voltage supply	Check AC supply

### Cleaning

Clean the outside of the fan with a damp cloth only. Do not use solvents. Periodic cleaning of the fan blades and grilles is necessary to maintain peak performance. Cleaning frequency depends on the operating environment. Inspect the fan regularly for dust and smoke residue buildup. Clean as soon as there is significant dirt buildup on fan blades or if airflow through grilles becomes restricted. Use a soft brush and vacuum to clean grilles and fan blades.

#### Cleaning Steps:

1. Disconnect power
2. Remove the screws to clean the housing and blades
3. After cleaning, make sure that screws are securely tightened

### Replacing the Fuse

ProFan uses a 10A, 125V cartridge-type wire fuse, 0.8"L x 0.21"DIA (20.46 x 5.34 mm):

1. Turn the fuse knob counter-clockwise
2. Replace fuse
3. Turn fuse knob clockwise

## 7. SAFETY INSTRUCTIONS



ProFan is designed to be used by professionals, and is NOT intended for household use. Improper use can cause severe injury due to electrical or mechanical hazards.

t

### Preventing Fire and Electric Shock

- Always ground (earth) the machine electrically.
- ProFan has a built-in speed control. Do not connect ProFan to any external solid-state speed control device or dimmer circuit.
- Disconnect the machine from power before removing any components or servicing, and when not in use.
- Moisture can cause dangerous electrical faults. Do not aim fog output at electrical connections or devices.
- Do not expose this machine to excess moisture. ProFan is NOT waterproof.
- Do not spill fluid over the machine. In the event of a fluid spill, disconnect the machine from power and clean with a damp cloth. If fluid is spilled onto electrical components, contact TMB.
- Do not dismantle or attempt to repair a faulty machine. Refer all service to TMB.
- Do not operate the machine if the power cable or connector is damaged. A damaged cable or connector must be replaced with a new item, available from TMB.
- Do not operate the machine with damaged, deformed or missing parts.

### Preventing Injuries

- Never allow any object or part of the body to enter the path of the fan blades. Ensure that clothing, cables or other items cannot be sucked into the fan.
- Disconnect power before removing cover or grille.
- Do not operate unless all covers and grilles are installed and securely fastened.
- Ensure that any supporting structure or surface can hold at least 10 times the weight of all installed devices.
- Use approved secondary attachment when possible, such as a safety cable.

## 8. APPENDIX

### Limited Warranty

ProFan products are warranted against defective materials or workmanship for a period of 12 months from the date of original shipment.

This warranty shall not apply to any defect arising from accident, misuse, or improper or unauthorized adjustment or repair. No warranty is given with respect to color media or lamps, or with respect to normal wear and tear.

Any claim for defective merchandise, imperfect manufacture, shortage in count, or for any other defect known by the Customer to be existing at time of delivery is waived by the Customer unless made in writing within 30 days after delivery.

All warranty parts will be charged to the customer until faulty parts (or product) are returned to TMB for valuation. These parts must be returned within 30 days of receipt or warranty is void and parts/shipping becomes billable items.

TMB will not assume any responsibility for any labor expended or materials used to replace and/or repair any equipment without TMB's prior written authorization. Any labor charges for repairing or replacing equipment in the field will be negotiated only between the Seller and general contractor. Freight terms on warranty repairs are FOB Seller's warehouse or factory. If warranty parts and/or repairs are required, Seller agrees to pay destination ground freight charges on the aforementioned items leaving the Seller's facility.

## Technical Specifications

<b>PHYSICAL</b>	Width	19" (480 mm)	
	Height	22" (560 mm)	
	Depth	18" (460 mm)	
	Weight	27.6 lbs (12.5 kg)	
	Mounting	Adjustable swivel yoke	
	Color	Black	
<b>ELECTRICAL</b>	Nominal voltage	100-240VAC, 50-60Hz	
	Maximum power consumption	1200W	
	Fuse	10A 125V cartridge, wire: (L x DIA) 0.8" x 0.21" (20.46 x 5.34mm):	
<b>PERFORMANCE</b>	Air Volume	1,700 cubic meters/hr [1000.5 cfm]	
	Wind Speed	60 km/hr [37.5 mph]	
	RPM	0 to 3,500 variable	
	Acceleration	Zero to full within 2 sec.	
<b>BACKPACK CONTROLLER</b>	Protocol	DMX-512A in/out	
	Control Modes	DMX and Manual	
	Electrical connection to fan housing	3-pin XLR male	
	DMX data in	5-pin XLR male	
	DMX data out	5-pin XLR female	
	DMX XLR pinout	1	Shield/Ground
		2	Data (-)
3		Data (+)	
4		-	
5		-	

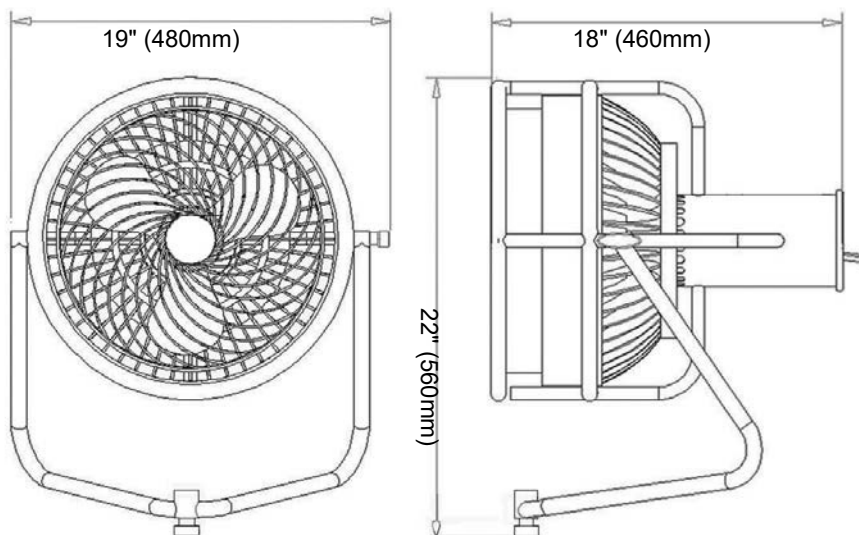

## CONTACT INFORMATION

### LOS ANGELES HEADQUARTERS

527 Park Avenue | San Fernando, CA 91340, USA

Tel: +1 818.899.8818 | Fax: +1 818.899.8813

sales@tmb.com

### TMB 24/7 TECH SUPPORT

US/Canada: +1.818.794.1286

Toll Free: 1.877.862.3833 (1.877.TMB.DUDE)

UK: +44 (0)20.8574.9739

Toll Free: 0800.652.5418

techsupport@tmb.com

LOS ANGELES +1 818.899.8818

LONDON +44 (0)20.8574.9700

NEW YORK +1 201.896.8600

BEIJING +86 10.8492.1587

CANADA +1 519.538.0888



A full service company providing technical support, customer service, and follow-up. Providing products and services for the industrial, entertainment, installation, defense, broadcast, research, telecommunications, and signage industries. Servicing the global market from offices in Los Angeles, London, New York, Toronto, and Beijing.