

SOLARIS PRELIMINARY

QUASAR 15K



15,000 WATT PROFESSIONAL STROBES

Versatile strobes that can be used anywhere either flash or constant light is required. Ideal for theatre, concert, dance club, and rental company applications. No comparable strobe in the world!

FEATURES

- Stainless steel body lasts for years
- 450,000 lumens maximum output!
- DMX512 control
- Continuous lighting capability (120Hz)
- Automatically controlled electronic safety feature
- Auto voltage sensing
- Thermal shut-down feature
- Highly accurate flashing system
- Three phase system capability
- Compact size
- SELF-Test functions, LED indicators
- Optional controllers can execute pre-programmed or customized lightning sequences at the push of a button or triggered via DMX512



LOS ANGELES

10643 Glenoaks Blvd.
Pacoima, CA 91331
USA

Tel: +1 818.899.8818
Fax: +1 818.899.8813

LONDON

21 Armstrong Way
Southall
UB2 4SD England

Tel: +44 (0)20.8574.9700
Fax: +44 (0)20.8574.9701

NEW YORK

100 Asia Place
Carlstadt, NJ 07072
USA

Tel: +1 201.896.8600
Fax: +1 201.896.8601

BEIJING

No. 309, Building 6
Sanlitun Nanlu
Chaoyang District
Beijing, China 100027

Tel: +86 10.8492.1587
Fax: +86 10.8492.7635

TORONTO

409 Saddler St. West
Box 654, Durham
Ontario N0G-1R0

Tel: +1 519.369.9990
Fax: +1 519.369.9992

QUASAR 15K SPECIFICATIONS

LAMP	Maximum continuous flash discharge	2.5 seconds	
	Frequency of continuous mode	120 Hz	
	Flash tube type	Proprietary Long Arc Xenon tube	
	Color temperature	5600° Kelvin	
CONTROL PARAMETERS	Intensity control		
	Adjustable flash frequency		
ELECTRONIC & SAFETY DEVICES	Overheating protection	80°C, 110 °C, self resetting	
	Self-test	Preprogrammed	
	Indicator LED'S	Red: POWER Yellow: MODE/PROTECTION Green: DATA	
CONTROL SYSTEM	Digital display and pushbutton programming of parameters		
	Number of channels	2	
	Connection type	5-Pin XLR	
	Supported Protocols	DMX512	
POWER SUPPLY	Nominal mains voltage	230/240 V - 50/60 Hz	
	Power requirement	20A breaker	
	Max. power draw	Continuous	60A
		Turbo	32A
FIXTURE & HOUSING	Protection from breaking flash tube	Soft spring suspension system	
	Fixing	Adjustable yoke	
	Corrosion protection	Stainless steel body	
	Unit Dimensions (HxWxD)	7.5" x 21.5" x 5.5" / 19 x 54.6 x 14 cm	
	Shipping Dimensions (HxWxD)	10.5" x 23.75" x 9" / 27 x 60.5 x 23 cm	
	Unit weight	7.8 lb. (3.6 Kg)	
	Shipping weight	10.6 lb. (4.8 Kg)	

Specifications and features are subject to change without notice.

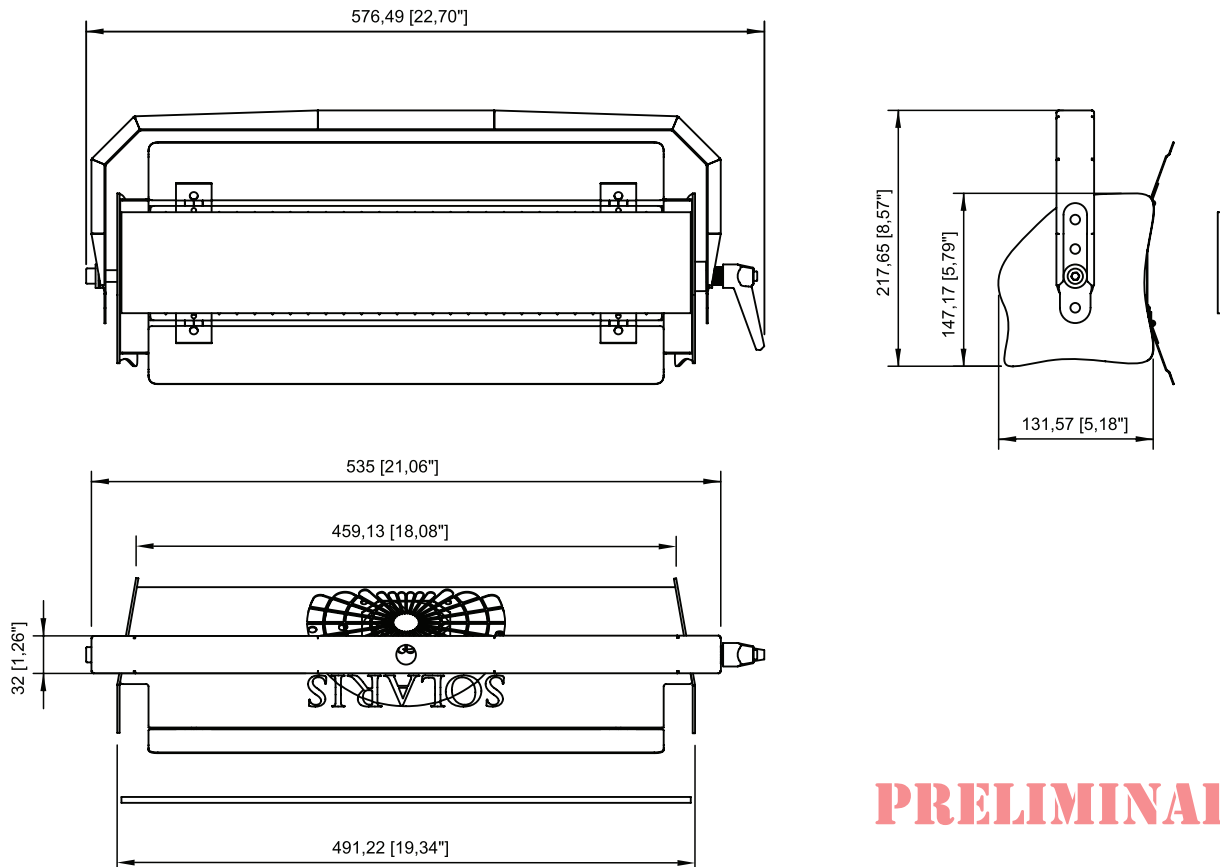

PRELIMINARY