



S O U R C E F O U R[®] jr/jr Zoom

User Manual

Production Dates: September 2004 - Present

Copyright © 2008 Electronic Theatre Controls, Inc.
All Rights reserved.
Product information and specifications subject to change.
Part Number: **7062M1200-06.01** Rev B
Released: June 2008

Picking# 7062M1001-B

Table of Contents

Basic Assembly	1
Fixture information	2
Color frame holder	2
Replacing the HPL lamp	4
Adjustments	5
Centering lamp and adjusting the field	5
Focusing the beam	5
Shaping the beam	6
Adjusting the C-clamp	7
Adjusting the yoke position	7
Lens and Reflector	9
Switching lens assemblies	9
Cleaning glass lens	10
Cleaning the reflector	10

ETC[®], Emphasis[®], Expression[®], Insight[™], Imagine[™], Focus[™], Express[™], Unison[®], Obsession[®] II, ETCNet2[™], EDMX[™], Source Four[®], Revolution[®], Sensor[®], and WYSILink[™] are either registered trademarks or trademarks of Electronic Theatre Controls, Inc. in the United States and other countries.

All other trademarks, both marked and not marked, are the property of their respective owners.

Basic Assembly

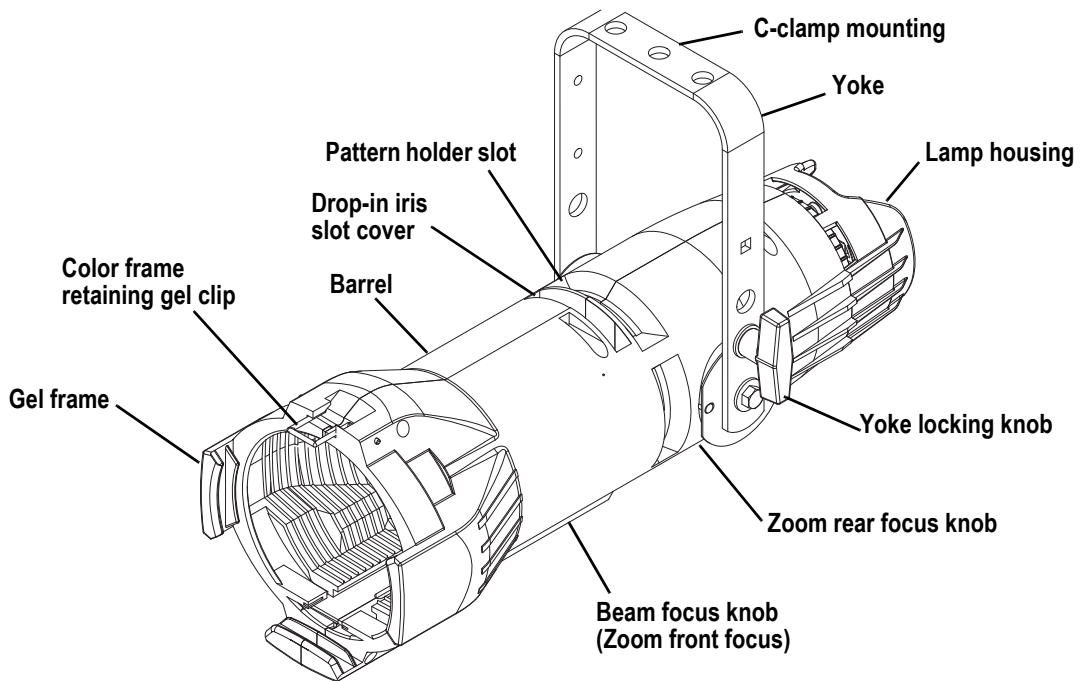

Figure 1



WARNING:

Please note the following safety warnings before use:

Do not mount the fixture on or near combustible surfaces.

Do not operate the fixture without a lens installed.

Always hang the fixture with the colour frame retaining clip in the locked position.

Fixture information

HPL lamp table



CAUTION: The Source Four jr is rated for 575w maximum lamp. Do not use lamps other than the HPL in Source Four fixtures. ***Use of lamps other than HPL or greater than 575w will void your warranty.***

Lamp code	Watts	Volts	Initial Lumen	Color temp.	Average rated life
HPL 550/77*	550	77	16,170	3,250°	300 hours
HPL 550/77X*	550	77	12,160	3,050°	2000 hours
HPL 575/115	575	115	16,520	3,250°K	300 hours
HPL 575/115X	575	115	12,360	3,050°K	2000 hours
HPL 375/115	375	115	10,540	3,250°K	300 hours
HPL 375/115X	375	115	8,000	3,050°K	1000 hours
HPL 575/120	575	120	16,520	3,250°K	300 hours
HPL 575/120X	575	120	12,360	3,050°K	2000 hours
HPL 575/230	575	230	14,900	3,200°K	400 hours
HPL 575/230X	575	230	11,780	3,050°K	1500 hours
HPL 375/230X	375	230	7,250	3,000°K	1000 hours
HPL 575/240	575	240	14,900	3,050°K	400 hours
HPL 575/240X	575	240	11,780	3,050°K	1500 hours
HPL 375/240X	375	240	7,250	3,000°K	1000 hours

* To be used with ETC Dimmer Doubler™

Color frame holder

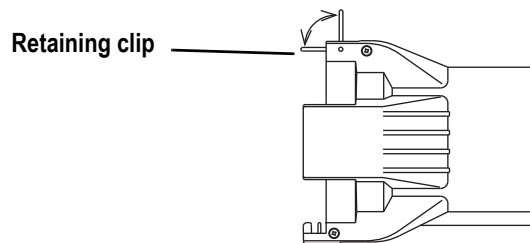

Figure 2

The color frame holder is equipped with a spring-loaded retaining clip that prevents color frames and accessories from falling out. See [Figure 2](#).



WARNING: ***Make sure all color frame accessories are locked in position with the retaining clip before hanging the Source Four.***

- Step 1: Release the retaining clip by pushing it sideways while gently pulling backwards.
- Step 2: Insert the color frame.

Step 3: Lock the retaining clip by pushing sideways while gently pushing forward.



Note:

The performance of saturated colors may be less than desirable in any theatrical lighting fixture. For best results, always use high-quality color media rated for high-temperature use.

ETC's optional Conical Gel Extender, part # 7060A1048, will provide maximum color media life. Gel Extenders are not recommended for 70° and 90° lens tubes due to the extremely wide-angle beam.

A variety of heat shield products is also available from many color media manufacturers. Follow the manufacturer's instructions for the use of these products.

Replacing the HPL lamp

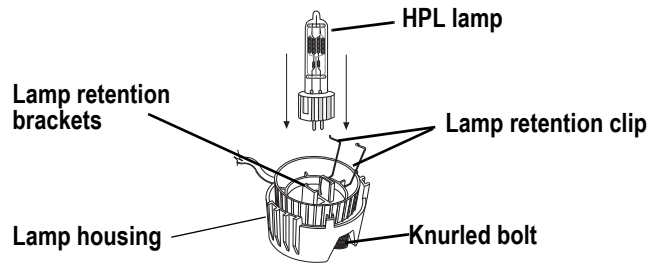

Figure 3

A lamp must be installed before you use the fixture.



Note: Verify that the HPL lamp you intend to install is suitable for your facility's voltage; 115-, 120-, 230-, and 240-volt HPL lamps are available. See [HPL lamp table, page 2](#). Operating HPL lamps above their rated voltage reduces lamp life and can cause premature lamp failure.



WARNING: Let the lamp cool before replacing.

- Step 1: Disconnect power to the fixture before installing the lamp.
- Step 2: Loosen the knurled bolt on the back of the lamp housing and pull the housing out.
- Step 3: Holding by the base, remove the HPL lamp from its box.



CAUTION: Use caution when installing or replacing any lamp. When installing/replacing lamp, be sure to point the lamp away from your face and away from others before inserting it firmly into the assembly. This may prevent injuries if the lamp should break.

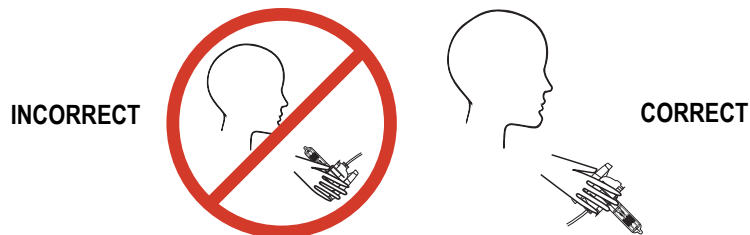

Note: To avoid premature lamp failure, do not touch the lamp glass. If you do, clean it carefully with isopropyl alcohol and a clean lint-free cloth. Allow to dry before operation.

- Step 4: Align the flat sides of the lamp base with the retention brackets on either side of the socket as shown in [Figure 3](#).
- Step 5: Push down on the lamp base until the lamp seats firmly. When properly installed, the top of the lamp's base will be even with the top edges of the retention brackets.



CAUTION: Improperly installed lamps cause premature lamp failure and socket problems.

- Step 6: Press lamp retaining clip across lamp base to secure.
- Step 7: Reinstall the lamp housing by aligning the bolt hole and tightening the knurled bolt

Adjustments

Centering lamp and adjusting the field

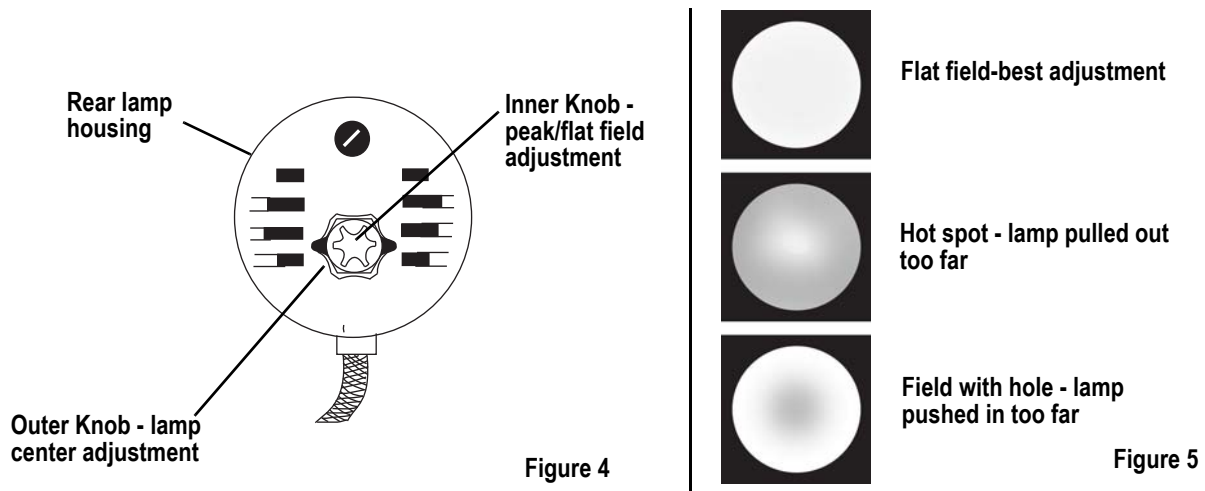

The two concentric knobs located on the lamp housing allow you to align the lamp and adjust its field. See [Figure 4](#). The outer knob centers the lamp within the reflector. The inner knob adjusts the lamp's field.

- Step 1: Turn on the fixture and aim it at a flat surface. Adjust the barrel to create a hard edge.
- Step 2: Unlock and loosen the outer knob by turning it counterclockwise.
- Step 3: Gently move the outer knob from side to side and up and down until the lamp is centered within the reflector.
- Step 4: Once the lamp is centered, turn the outer knob clockwise to lock it in place.
- Step 5: Finally, turn the inner knob either clockwise or counterclockwise to achieve an optimum flat field. See [Figure 5](#).

Focusing the beam

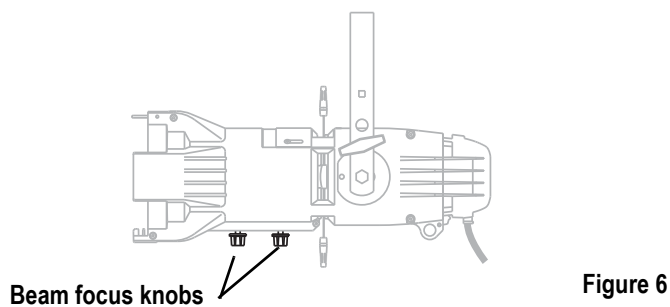

On a fixed field angle Source Four jr., with a 26°, 36° or 50° lens, adjust the lens single beam focus knob to focus the edge of the beam. On a Source Four jr Zoom, adjust the position of both lens beam focus knobs to set the beam's spread and to focus the edge of the beam. The Zoom lens provide a range from 25° to 50°.

- Step 1: Loosen the beam focus knob(s) on the underside of the barrel as shown in [Figure 6](#).
- Step 2: Slide the lens(es) forward or backward to achieve the desired beam edge.
- Step 3: Once the fixture is focused, tighten the beam focus knob(s).

Shaping the beam

The beam can be shaped using the shutters (see [Figure 1](#), a pattern or an optional drop-in iris.

Pattern Projection

The pattern holder slot is on the top side of the barrel and in front of the shutters. It accommodates an **M-size pattern holder** (see [Figure 7](#)). The pattern holder handle can be bent away from the shutter handle to keep it from interfering with the action of the shutter handle.

Use an optional donut in the accessory holder to enhance pattern projection. Donut diameter range should be 2.5" to 2.75".

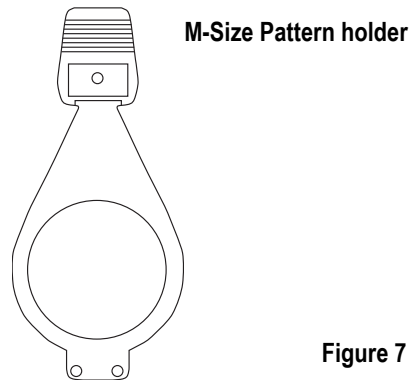

Figure 7

Drop-In Iris Slot

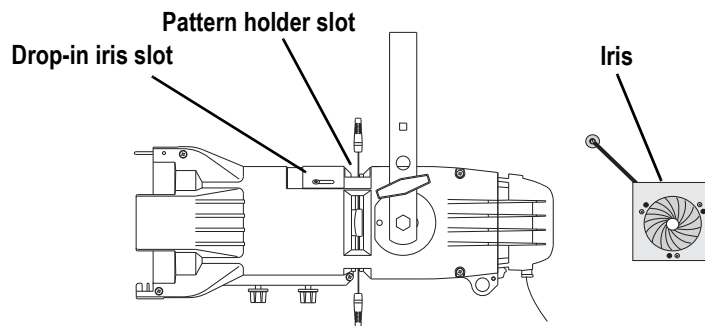

Figure 8

The drop-in iris slot is located on the top of the barrel and in front of the pattern holder slot. It accommodates either a drop-in iris or a motorized pattern device. When the slot is not in use, a small sheet metal cover secured with two Phillips screws prevents light leakage (see [Figure 8](#)).

- Step 1: Use a Phillips screwdriver to loosen the screws on the drop-in iris slot cover. **Do not remove screws.**
- Step 2: Slide the cover completely forward to expose the slot.
- Step 3: Insert the iris with the flat side toward the shutters and make sure the iris handle extends from the slot.
- Step 4: Slide the slot cover back toward the shutters until it meets the iris handle. Leave enough space to move the iris handle.
- Step 5: Secure the drop-in iris slot cover by tightening the screws.

Adjusting the C-clamp

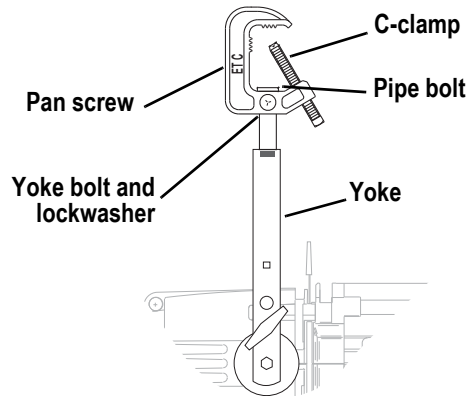

Figure 9

The C-clamp attaches the fixture to the mounting pipe and allows you to adjust the position of the fixture once it is mounted (see [Figure 9](#)).

- Step 1: Tightly fasten the C-clamp to the yoke with the provided yoke bolt and lock washer.
- Step 2: Place the C-clamp on mounting pipe, then tighten the pipe bolt to secure it.
- Step 3: Loosen the C-clamp pan screw and rotate the yoke to the desired position.
- Step 4: Tighten the pan screw to lock the fixture.

Adjusting the yoke position

The Source Four jr / jr Zoom provide multi-positioning capabilities within its yoke for overall fixture height and angle.

Setting the fixture height within the yoke

The fixture is equipped with a two-position yoke for modifying the overall height in which the fixture is mounted (see [Figure 10](#)). To change the height position, perform the following steps.

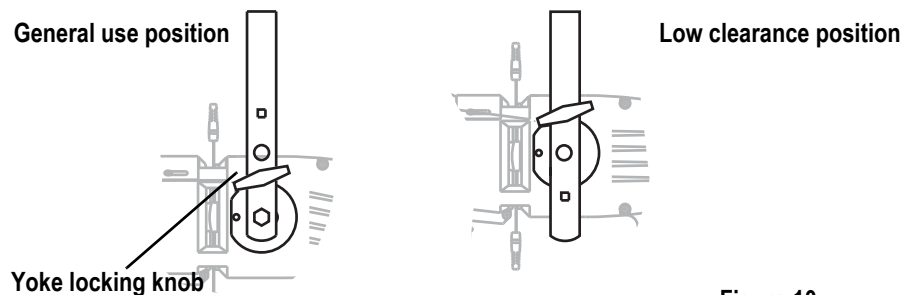

Figure 10

- Step 1: Remove the yoke locking knobs, washers, and hex bolts from either side of the fixture.
- Step 2: Raise or lower the fixture to the desired position within the yoke.
- Step 3: Reinstall the yoke's hex bolts, washers, and locking knobs.
- Step 4: Tighten the yoke knobs to secure in position.

Setting the angle within the yoke

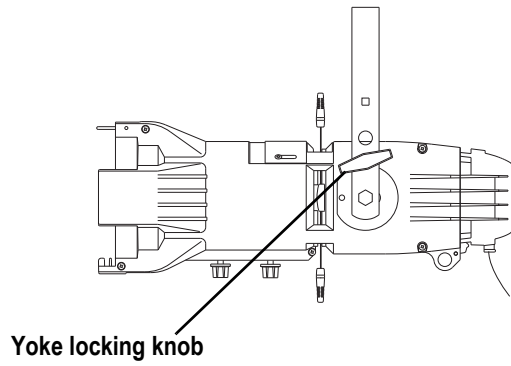

Figure 11

- Step 1: Loosen the yoke locking knobs (see [Figure 11](#)). **Do not** remove them.
- Step 2: Tilt the fixture to the desired position.
- Step 3: Tighten the yoke locking knobs to secure in position.

Lens and Reflector

Switching lens assemblies

Follow these procedures to replace a fixed field lens with Zoom lens.

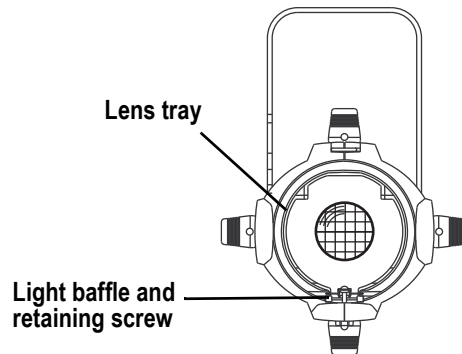

Figure 12

- Step 1: Loosen the screw at the front of the baffle. See [Figure 12](#).
- Step 2: Pull the light baffle out of the barrel.
- Step 3: Remove the beam focus knob from the bottom of the barrel and slide the lens assembly from the barrel.
- Step 4: Slide the Zoom lens rear assembly into the barrel and install its beam focus knob.
- Step 5: Slide the Zoom lens front assembly into the barrel and install its beam focus knob.
- Step 6: Reinstall the light baffle and secure it with the retaining screw.



Note: *Reverse steps 1-6 to replace Zoom lens with a standard lens.*

Cleaning glass lens



WARNING: *Do not use ammonia-based or other harsh commercial cleaners. Clean lens only as directed.*

Commercially available glass cleaning agents should be avoided as they may contain ammonia, other harsh chemical detergents or abrasive agents. These cleaners may damage the glass surface and the Anti-Reflective coatings. Do not immerse or soak the glass in any cleaning solution.

Replace lenses if they contain visible damage (cracks or deep scratches) that may impair their effectiveness.

- Step 1: Remove the lens assembly. See Source Four jr / jr Zoom Assembly Guide for lens removal instructions.
- Step 2: Remove dust with a blast of oil-free air or wipe with a clean, lint-free cloth. Isopropyl alcohol, distilled water or a 50%-50% mixture of each can be used to clean the glass surface.
- Step 3: Reinstall the lens assembly.

Cleaning the reflector



WARNING: *Unplug the fixture before attempting to clean the reflector.*



WARNING: *Do not use ammonia-based or other harsh commercial cleaners. Clean reflector only as directed.*

Commercially available glass cleaning agents should be avoided as they may contain ammonia, other harsh chemical detergents or abrasive agents. These cleaners may damage the glass surface and the Anti-Reflective coatings. Do not immerse or soak the glass in any cleaning solution.

To quickly clean the reflector, and. You may also wipe the reflector with a clean lint-free cloth. If either method is not sufficient, follow these steps.

- Step 1: To protect the lamp housing during cleaning, remove the lamp housing by loosening the knurled bolt and pulling the housing straight out. See [Figure 3](#).
- Step 2: Remove the lens. See Source Four jr / jr Zoom Assembly Guide for full fixture disassembly/assembly instructions.
- Step 3: Remove dust with a blast of oil-free air or wipe with a clean, lint-free cloth. Isopropyl alcohol, distilled water or a 50%-50% mixture of each can be used to clean the glass surface.
- Step 4: Reinstall the lamp housing and tighten the knurled bolt.
- Step 5: Reinstall the lens.



Corporate Headquarters ■ 3031 Pleasant View Road, P.O. Box 620979, Middleton, Wisconsin 53562-0979 USA ■ Tel +608 831 4116 ■ Fax +608 836 1736
London, UK ■ Unit 26-28, Victoria Industrial Estate, Victoria Road, London W3 6UU, UK ■ Tel +44 (0)20 8896 1000 ■ Fax +44 (0)20 8896 2000
Rome, IT ■ Via Ennio Quirino Visconti, 11, 00193 Rome, Italy ■ Tel +39 (06) 32 111 683 ■ Fax +39 (06) 32 656 990
Holzkirchen, DE ■ Ohmstrasse 3, 83607 Holzkirchen, Germany ■ Tel +49 (80 24) 47 00-0 ■ Fax +49 (80 24) 47 00-3 00
Hong Kong ■ Rm 1801, 18/F, Tower 1 Phase 1, Enterprise Square, 9 Sheung Yuet Road, Kowloon Bay, Kowloon, Hong Kong ■ Tel +852 2799 1220 ■ Fax +852 2799 9325
Service: (Americas) service@etcconnect.com ■ (UK) service@etc europe.com ■ (DE) techserv-hoki@etcconnect.com ■ (Asia) service@etcasia.com
Web: www.etcconnect.com ■ Copyright © 2008 ETC. All Rights Reserved. ■ Product information and specifications subject to change.
7062M1200-06.01 ■ Rev B ■ Released 06/2008